

# your computer

\$2.50\*  
NZ \$3.25



AUDITED SALES  
AUSTRALIA'S  
TOP-SELLING  
COMPUTER  
MAGAZINE

WIN  
A CASIO  
COMPUTER!  
SPECIAL SUBSCRIPTION OFFER

OCTOBER, 1984

MAGAZINE

FOR BUSINESS AND PLEASURE

## DATA COMMUNICATIONS

- Talking to the World

- Databases
- MIDAS, Minerva and More . . .

**SINCLAIR QL REVIEW!**



### YOUR BUSINESS COMPUTER:

Terminals  
— Are you Dumb or Smart?  
Corporate MBA Reviewed.

Registered for posting as a publication.  
Publication No. NBP4384. ISSN 0725-3931.

# Roland Quality Affordable Prices



## **ROLAND DG CC141**

- 14" RGB Color Monitor.**
- High Resolution (640 dot, 2000 character capacity).
  - Non-glare, high contrast CRT giving vivid color and sharp image.
  - Up to 256 colors.

## **ROLAND MB122 MONOCHROME SCREENS**

- Ultra-high resolution (720 dot x 350 lines).
- Non-glare CRT's in long-life (P-39) green phosphor and amber (PDB).
- Built-in cable plugs directly into IBM PC.

## **MB121 COMPOSITE MONITORS**

- High resolution monochrome monitors also available in green and amber.
- Compatible with most PC's, including IBM via color graphics board.



## **ROLAND DXY GRAPHIC PLOTTERS**

8-pen color plotter (DXY-800) and single-pen plotter (DXY-101) offer high quality performance at incredible price. With A3 image area, twin-speed, serial and parallel interfaces, both units will operate either flat or standing.

**JUST RELEASED**  
Available with drivers for Lotus 1, 2, 3, AutoCAD, and most popular business and technical software.

## **STB EXPANSION BOARDS FOR IBM & COMPATIBLES**

**Graphix Plus** — Multi-function video board combines color and monochrome text and graphics, parallel printer and light pen ports, print buffer and RAM disk.

**RIO PLUS** — Multi-function RAM expansion board includes RS 232C serial and Centronics parallel ports for peripheral interfacing, super RAM-disk emulator, printer spooler software, battery-backed clock/calendar and joystick port.

All products backed by Roland service & full 12-months warranty. See your nearest dealer for details on all products.

# Roland



**Roland Corporation Australia Pty. Ltd.**

39 Victoria Street, Fitzroy, 3065.  
Telephone: (03) 417 1800. Telex: 35276.  
23 Cross Street, Brookvale, 2100.  
Telephone: (02) 938 3911. Telex: 27769.

ROL-A015

# d foreign language.

2 or 3

```
.list files
  DATABASE FILES NBRRCOS LAST UPDATE
  HOMES DBF 1005 11/01/83
.use homes
.list homes selling for < 50000
*** SYNTAX ERROR *** RE-ENTER
.list structure
  FLD NAME TYPE WIDTH DEC
  001 ADDRESS C 025
  002 SELLPRICE N 009 002
  003 AGENT C 025
.list for sellprice < 50000
```

# R language.

Gimme those turkeys.

Let's suppose you want a list of every home under \$50,000.

Say "Gimme those turkeys" to any other database management system and all you'll get is a blank stare from the screen.

But once you tell R:base that "turkeys" mean "homes under \$50,000," and that "gimme" means "list," you don't have to tell it again.

That's because R:base has the industry's only plain-and-simple conversation option for microcomputers. An artificial intelligence system that actually learns from you as you go along.

Which means no more difficult programming routines just to get a piece of information. Or lines and lines of code for a routine operation. All R:base asks for is some good conversation.

But there's a lot more to R:base than just friendliness.

See for yourself. Visit your local Imagineering IBM PC microcomputer dealer now or call Imagineering for the name of your nearest outlet.



**IMAGINEERING™**  
"The Art of Software"

579 Harris Street, Ultimo N.S.W.  
Telephone: (02) 212 1411

# R:base

It's easy when you do it R way.

**EDITOR**

Jane Mackenzie

**CONSULTING EDITOR**

Les Bell

**ASSISTANT EDITORS**

Natalie Filatoff, Evan McHugh

**ART & DESIGN**

Ali White

**ART PRODUCTION**

Vicki Jones, Brian Jones, Toni Henson

**AD PRODUCTION**

Peter Maxwell

**MANAGING EDITOR**

Jamieson Rowe

**PUBLISHER**

Michael Hannan

**CONTRIBUTORS**

Australia: Brendan Akhurst, Bill Bolton, Lloyd Borrett, David Brudenall, Geoff Cohen, Andrew Farrell, Frank Lee, Peter Lynden, Bruce Mitchell, Mike Newnham, John Nicholls, Jeff Richards, Rod Stevenson, Ernie Sugrue, Dom Swinkels, Bradley Thurkettle.  
United States: Howard Karten.

**OFFICE SERVICES**

Cassie Bailey

**ADVERTISING**

Richard Pakalnis (Group Advertising Manager)

David McDowell (National Advertising Manager)

Eric Baines and David Farrington (Victoria)

**SUBSCRIPTION ENQUIRIES**

Julie Plummer

**OFFICES****NSW**

140 Joynton Ave, Waterloo 2017.  
(02) 663-9999  
Telex: FEDPUB AA74488

**VICTORIA**

150 Lonsdale St, Melbourne 3000.  
(03) 662-1222  
Telex: FEDPUB AA34340

**WESTERN AUSTRALIA**

Ian Greenacre, Gordon & Gotch Adv't,  
134-144 Parry St, Perth 6000.  
(09) 328-8044

**QUEENSLAND**

Craig Santilla, Media Services  
4 Adelaide Terrace, Brisbane 4000  
(07) 229-6033

**SOUTH AUSTRALIA**

Steve Birbeck, Admedia Group,  
24 Kensington Rd, Rose Park 5067.  
(08) 332-8144

**NEW ZEALAND**

Chris Horsley, 4A Symonds Court,  
Symonds St, Auckland NZ.  
Telex: TEXTURE 260753

**Source Mail:** Les Bell TCY314; Matt Whelan TCY267.

**MICC Bulletin Board:** (02) 662-1686 — Les Bell 1085, Matt Whelan 1, or leave a message in comments.

**YOUR COMPUTER** is published monthly by the Federal Publishing Co Pty Ltd. Printed by ESN — The Litho Centre, Waterloo 2017, phone (02) 662-8888.

**Editorial and NSW Advertising:**

140 Joynton Avenue, Waterloo 2017.  
Telex: FEDPUB AA74488.

Typeset by Hughes Phototype, Spit Junction NSW. Phone (02) 960-2788. Distributed nationally by Gordon & Gotch. Registered for posting as a publication — Publication No. NBP4384. See back page for information on copyright, contributions, reader services and subscriptions.

\*Recommended and maximum price only.  
ISSN 0725-3931

# Information Overload

*Without a doubt, this is the year of integrated software — sorry, Integrated Software. There are now well over 20 different products on the market claiming to offer some form of integration of separate functions.*

*Integration works on two levels. First, the software must be able to transfer data between the different subsystems of the product, where it makes sense to do so: transferring summarised database information into a spreadsheet, for example, or spreadsheet data into graphics.*

*Integration must also take place on a second level: that of command structure. The command to delete, for example, should be the same all through the system, from application to application, and from data type to data type. Deleting a file, for example, should be done in the same way as deleting a spreadsheet cell contents.*

*It is in the latter area that most of the current crop of products fall down. They all offer varying degrees of data transfer, but it is primarily in the area of complexity of command language that things are going wrong.*

*The Lotus 1-2-3 concept of integrating graphics with a spreadsheet and tossing in some data manipulation functions — together with simple macro programming — is just about the right level for most users. Many people still find Lotus 1-2-3 too complex for their needs.*

*The new multi-function integrated software packages have been designed on the assumption that if integrating three functions worked well for Lotus, integrating five or six should work twice as well. I am not convinced that this is correct; the indications are that many users would willingly trade power for simplicity, at least in their first encounters with business software.*

*The integrated packages are therefore meeting with a more luke-warm reception than I had expected. Already, some winners and some losers are emerging in the marketplace, although it is a little early to comment on just what's going to happen in the long run.*

*One thing that has emerged, however, is that reviewing these packages is not an easy task. Major deficiencies simply do not show up until after weeks of use on real tasks. We have five such packages in the office for testing at present, and we're having to work out completely new techniques for evaluating them.*

*All this is by way of saying that we're not rushing into print with a quick comparison of these products. We're working on a full comparison and will have it finished shortly. In the meantime, I'd suggest that you perform your own evaluations with care and consider carefully whether you really need integrated software or whether separate components might be a better solution for the short term, at least.*

Vice President of New Technology, Ashton-Tate — Wayne Ratliff said:  
“Although we have kept all the features of DBASE II  
that have made it so popular, we rewrote DBASE III in ‘C’ language from the ground up  
to have greater capabilities, storage, speed, power and ease of use,  
and to take advantage of the power and technology of 16 bit and larger computers.”

# dBASE™ III goes II

*Faster ✓  
More ✓  
Really easy to use ✓  
powerful ✓*

# BETTER

## Features of DBASE III

1. Over 2,000,000,000 records per data base
2. 128 fields per record
3. Variable length text field up to 4K bytes per entry
4. 4,000 bytes per record
5. 10 data base files in use simultaneously
6. Fast internal sort and improved indexing
7. 16 digits of numerical accuracy
8. Enhanced reports capability
9. On line help system
10. Full screen formatting

## System Requirements

1. IBM PC XT and all PC compatible computers
2. Minimum 256K bytes RAM, two 5¼" floppy disc drives
3. Monochrome or colour display, any printer with at least 80 columns
4. PCDOS 2.0 operating system

ASHTON-TATE ■™

distributed by **ar**compacific

Contact your local dealer for more information or write to  
Arcom Pacific, Freepost 2, P.O. Box 13, Clayfield Q 4011

# Your computer



Remote Databases 20



Using the Your Computer Bulletin Board 44



Call Me Modem Talking to LA 75

## DATA COMMUNICATIONS

**COMMUNICATIONS – INTO THE FUTURE** 19  
*An introduction to the possibilities of data communications.* LES BELL

**REMOTE DATABASES** 20  
*From small special-interest databases such as movie reviews to huge monsters with millions of pieces of data, the information available now on remote databases is limitless – and growing.*

**LET'S DIALOG** 23  
*Dialog is a general-interest database in the USA that is fairly representative of what's being offered these days to computer users with communications facilities.* FRANK LEE

**MINERVA** 32  
*Minerva is OTC's latest offering – an international electronic messaging system. Aimed primarily at business users, it gives cheap access to such facilities as electronic mail, a world news service, electronic conferencing and several applications programs.* FRANK LEE

**THE BEGINNINGS OF RCPM** 40  
*Remote message systems – 'bulletin boards' or 'RCPMs' – started some time in 1978 in Chicago, and spread rapidly if not always legally. In Australia Telecom provided a few special hindrances, but now these systems are thriving.* BILL BOLTON

**USING THE YOUR COMPUTER BULLETIN BOARD** 44  
*New documentation on operating the Your Computer bulletin board hasn't been issued for some time, so here's an update on everything you need to know.* EVAN McHUGH

**TALKING TO LA** 57  
*Cathy Gray, the editor of Sonics magazine, didn't have anything to do with computers or data communications until she started to need up-to-date information on the music world from the USA. In no time at all, through the Your Computer bulletin board, she was 'talking' to the other side of the world as easily as if she was using the telephone.* CATHY GRAY

**CALL ME MODEM** 75  
*If you're going into data communications, you have to have a modem. This article discusses the attributes of a modem, and includes a list of modems that we know to be available in Australia.* EVAN McHUGH

More on data communications in our next issue: local area networks, packet-switching systems like Austpac, and more!

# HOLLYWOOD

## REVIEWS

### HOW BIG IS A QUANTUM LEAP? 82

Sinclair's latest micro, the QL (short for 'Quantum Leap') has been released in the UK amid a lot of fanfare – and long delivery delays.

Tim Hartnell, a Sinclair hacker from way back, put the new machine through its paces. **TIM HARTNELL**



### VISUAL 1050 97

The Visual 1050 is Visual Technology's departure from manufacturing graphics terminals into the world of complete computers. Their first offering looks like a good one.

**JOHN NICHOLLS AND JEFF RICHARDS**

Cover photos courtesy of STC Cannon (world), Tektronix (terminal) and AUSSAT (satellite).

## SPECIALS

### NASHUA FLOPPY DISKS – SPECIAL OFFER 93

### COMPETITION – WIN A DATABASE PROGRAM 95

Win a copy of KnowledgeMan, the database management program that received such a good review in last month's issue of *Your Computer*.



99

**SUBSCRIBE TO YOUR COMPUTER WIN A CASIO COMPUTER!**

## YOUR BUSINESS COMPUTER

This month's business section features an in-depth look at terminals – what to look for when you buy; plus a review of Corporate MBA, the latest competitor for Lotus's top position in the business software world; and a novel viewpoint on computer security from our US correspondent, Howard Karten.

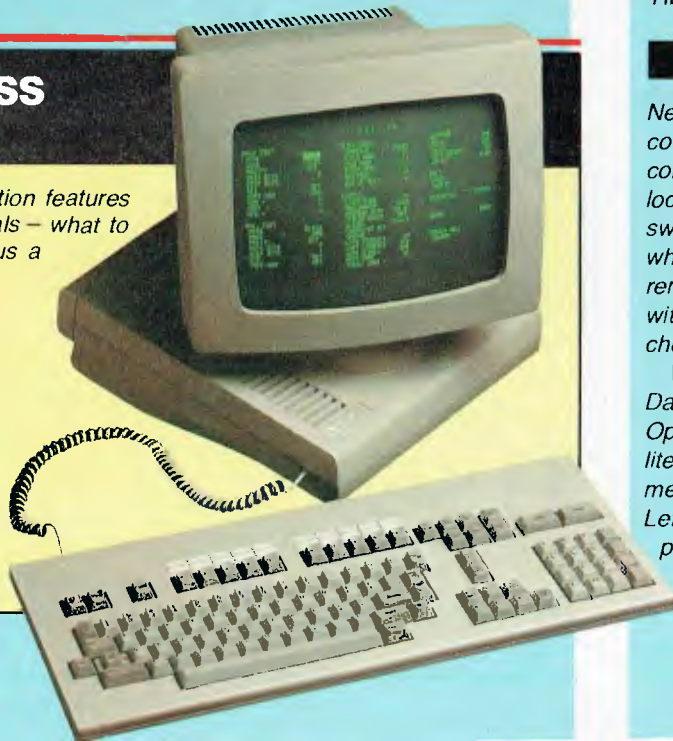

## COLUMNS

BBC	104
KAYPRO	109
LOTUS HOTLINE	114
TI	120
ATARI	125

## DEPARTMENTS

YOUR COMPUTER NEWS	9
DIARY	113
MARKET DIRECTORY	128
READER SERVICES	130

## NEXT MONTH

Next month we continue our coverage of the world of data communications with articles on local area networks and packet-switching systems such as Austpac, which enable computer users in remote locations to communicate with each other easily and cheaply.

We also continue the Great Database Search with a review of Optimum, which styles itself in its literature as a 'database management system development tool'. Let's hope it lives up to the promise! Plus all our usual reviews, features, news and columns – don't miss it!

# HI-TECH C

An Australian developed C Compiler  
that runs rings around the opposition.

## Features:

- Compiles Full V7 C — including enums and structure operations
- 50%-100% faster code than any competing Compiler
- Complete I/O library
- Source for libraries included — no royalties
- Easy to use — one command compiles, assembles and links
- Powerful debugging tool included
- Command line I/O redirection
- FAST floating point
- Locally developed and supported
- Supports ROM-based software
- Includes MACRO assembler, linker and librarian

## Disc formats:

CP/M: 8" SSSD  
Most 5¼" formats  
(add \$5 for 5¼" formats)  
MSDOS  
CP/M-86 Most formats

**Pricing:** (includes 12 months support)

Z80	\$250
8086	\$300

We can supply to special order development software for any type of microprocessor — at competitive prices with the advantage of local support. Contact us for further details.

## System Requirements:

Z80 56K  
or  
CP/M2.2  
MSDOS 2.  
or  
CP/M-86

**Z80 and 8086 versions now available.**

## HI-TECH SOFTWARE

PO Box 118, Eastwood, 2122. Ph. (02) 85 4552

## IBM Back in Centre Stage

FOR SOME TIME now the name 'IBM' has been associated almost exclusively with the suffix -PC, and has elicited little but yawns from the computer-aware community. The PC Junior failed as an eye-opener, and while several tantalising rumours have issued from the vicinity of Big Blue headquarters, and the PC Portable looked promising, most IBM watchers seemed to have gone back to sleep ...

Well, everyone's sitting up now, all ears, and rubbing their eyes too. As you must have heard, International Business Machines Corp is back in centre stage, following the announcement of a new high-powered computer, an office computer network, the first of its own software packages and a number of other associated titbits - with aggressive pricing as the overall theme. The fanfare is said to sound more like a siren in the offices of other multi-user personal computer manufacturers, and even some minicomputer producers are reported to be experiencing an uncomfortable ringing in the ears.

The main cause of all this cymbal bashing is a new IBM desktop computer which, with the addition of other terminals, can serve three users simultaneously. You may have heard it referred to as the 'Popcorn', but its real title is IBM-PC AT - the new suffix stands for 'advanced technology'.

The basic AT is priced at \$US3995, which includes 256K of memory and a 1.2 megabyte disk drive (a capacity thrice that of the more expensive PC). This can be expanded to a \$US6579 model with 512K of memory, a 1.2 megabyte disk drive and a new 20-megabyte fixed disk drive. Both models operate on the new 32-bit Intel 8026 processor, and have 84-key keyboards and eight expansion slots for additional devices and memory.

The IBM limitation of three users to each PC AT may be to encourage sales of its computer network system, launched on the same occasion.

The network enables as many as 72 desktop computers, printers and electronic files to exchange data, and IBM claims it is possible for up to 1000 PCs to be linked in a professionally designed and installed broadband network.

The release of IBM's internally developed 'windowing' program 'Topview', which allows the computer screen to be split into several sections for separate tasks, has been interpreted by many as a sign that IBM will move aggressively into the software market.

IBM called the \$US149 package, "A key foundation for future applications", and will make it available for all PC models. Topview requires 256K of user memory; two double-sided disk drives, or one double-sided diskette and a fixed disk; an 80-column screen; and DOS versions 2.0, 2.1 or 3.0.

If the windowing concept reminds you a little of Apple's Macintosh and Lisa, the news that a mouse device will also be released for Topview could lend further credence to the theory that IBM intends to take a hefty bite of Apple's market share.

Topview will not be available in the US until the first quarter of 1985, and IBM is evidently expecting it will appeal to software developers, especially those interested in micro-to-mainframe links, as a programmers' 'Toolkit' is also being offered for an extra \$395.

Finally, Big Blue has also announced the introduction of a wide range of new features for the PC Junior. Current owners of the Junior are entitled to a new, typewriter-style keyboard at no extra charge. They can also purchase a 128 kilobyte memory expansion attachment for \$US325; a program which allows all or part of the expanded memory to be transformed into an 'electronic diskette'; a \$US150 attachment to expand the computer's power source; and a \$US300 voice synthesiser.

For prospective buyers an enhanced Junior is now available, which incorporates 128K of memory, a built-in 360K disk drive and the new keyboard, for \$US999.

It's a lot to take in at once, but we people Downunder have quite a while to ponder these new developments, since it isn't known when the new IBM products will be available here.

For more information, contact IBM Australia, 100 Walker Street, North Sydney 2060; phone (02) 923 5123.

## Hioki Introduces New Plotter

A NEW professional-grade X-Y plotter is on the scene. It is the model 8401 from Hioki, a compact, relatively inexpensive machine which features 74 in-built plotting commands, optional plug-in expansion RAMs with memory up to 7K and continuous plotting capability.

The Hioki has cassette-type interfaces, allowing a choice of 8-bit parallel (Centronics), RS232C and GP-IB operation.

There is also a choice of three different types of pens (in four colours): ballpoint, plastic-tip and plastic water-based pens for overhead transparencies. All may be checked visually for ink supply.

To maintain printing quality at a pen speed of 450 mm/s (axial direction), the plotter uses a paper grip method which moves both pen and chart simultane-

ously. Both A4/A and A3/B chart sizes can be accommodated.

The 8401 retails for \$1900 and is distributed in Australia by Nilsen Rowe: phone (03) 347 9166.

## Music and the Bee

IN OUR July 1984 feature on Computers and Music, we reviewed the BeeThoven/BeeComposer music system for the Microbee. Applied Technology has since let us know that it is now manufacturing and distributing the package under licence, at a new price of \$99 for both items, including all cables and manuals.

You can contact Applied Technology at 1 Pattison Ave, Waitara 2077; (02) 487 2711.

## Computers and Advice for Small Businesses

COMPUTER Realm at Suite 1, 100a Young Street, Frankston, is set for a busy year. Its managers, Lance Collins and Peter Ibbotson, see the small business end of the computer market expanding and have set themselves up to provide advice, hardware and software to satisfy individual needs.

Their range includes Columbia, Fox, Kaypro and Sanyo computers, and some unusual software. These latter packages include the UK-designed typesetting package, Page Planner, which allows you to typeset direct from your computer keyboard; Videoscope, a video library system; and Dated, a medical accounting system.



## Apples for Teachers and Students

AS you might have read in the September issue of *Your Computer*, the Association of Independent Schools of New South Wales has begun running courses for parents, students and teachers who want to know more about the applications of computers in education. The first of the AIS teaching centres is located in Wynyard House in Sydney, and Apple Computer Australia has recently equipped a similar centre at Abbotsleigh girls' school in the Sydney suburb of Wahroonga.

Apple has supplied the school with 19 Apple Iles and one Apple IIc for an indefinite loan period. During school hours the classroom will be fully utilised by the students at Abbotsleigh, and in the evenings it will be used for AIS courses. □



## New Printer Released

MULTITECH Computers has announced the release of the Super5-CPA80 printer. The Super5 offers a wide variety of character sets that can be varied under software control. Most micro, personal and office computers can drive the Super5.

Multitech is also sole distributor of the Perfect range of diskettes. The two lines Multitech is concentrating on are MD 1D single-sided double-density and MD 2D double-sided double-density diskettes.

You can contact Multitech at 202 High St, Northcote 3070; (03) 489 0430. □



## Arcosm Shake-up brings Prices Down

ARCOM Pacific, Australian distributor of Ashton-Tate, Digital Research and Sorcim software, has cut its prices by up to 25 per cent following the recent government decision to remove import duty on software. In the wake of this decision, Arcosm has made a complete re-appraisal of its marketing structure, abandoning the use of sub-distributors in order to strengthen its link with dealers and react faster to user needs.

The biggest price reductions are on Ashton-Tate products, with dBase II reduced from \$840 to \$540, Friday! down to \$325 and dBase III and Framework

both selling for \$795. Average prices on Sorcim and Digital Research software are down 20 per cent and 15 per cent respectively. Supercalc 3, Sorcim's reply to Lotus 1-2-3, now costs \$422 – less than half the price of Lotus – and Digital Research's Pascal MT+ has been reduced over one hundred dollars to \$738.

In many cases, these new Arcosm prices are lower than the US equivalents, which is a welcome turnaround.

Full details can be obtained from Arcosm Pacific, 252 Abbotsford Road, Mayne 4006; (07) 52 9522. □

## Official Opening of IBM's Wangaratta PC Factory

THE official opening of IBM Australia's PC manufacturing plant in Wangaratta, Victoria, was held at the end of August. Mr Jack Simpson, Victorian Minister for Labour and Industry, did the honours, and also presented an IBM XT model to the Brotherhood of St Lawrence for use in training disabled people.

IBM flew many media reps down to Wangaratta for the day, and our managing editor Jim Rowe was among them. He reports that IBM Managing Director Brian Finn wouldn't reveal the Wangaratta plant's current production figures, but when the visitors were later shown around the plant itself, they saw what was described as "this afternoon's shipment" sitting on the despatch dock. As this consisted of about 30 PCs, 30 XT's and a few monitors, it suggests that current production may be around 300 systems per week.

The PC production plant itself was a bit of an anti-climax, according to Jim. Virtually all the component subassemblies are made overseas at present – motherboard, plug-ins, disk drives, power supply, even the keyboard and case. So all that is left to do at Wangaratta is

screw them all together, put them through a heat run for a few hours and give them a final test before packing them for despatch – none of which is terribly exciting.

Nor does it involve many people. Jim saw only about 20 people actually involved in PC production, hardly enough to solve the problems of unemployment even in Wangaratta. Still, IBM is looking into getting things like the PC boards made locally, so it may just be the gumnut from which a mighty Oz PC manufacturing industry will grow – although even this seems a little unlikely, because we understand that IBM's main PC plant in Boca Raton, Florida, is only slightly bigger.

Our main hope seems to lie on the software side, where IBM appears to be actively encouraging and working with local software writers. They're also getting local firms to print the various operating manuals. And even the Wangaratta plant itself will be bigger soon when the Selectric typewriter line closes; a second PC line will then go in alongside the first, early in 1985.

Wangaratta is officially the sole source of PC product for Australia, New Zealand and South-East Asia. □

The final diagnostic check from a worker wired for anti-static!



## FILE TRANSFERS

- 5¼" and 8" diskettes
- CP/M 80 and CP/M 86
- Turbodos, CDOS, MPM
- IBM 3740 datasets, DEC RX01
- MSDOS soon
- New formats being developed

## TETRAD SYSTEMS

P.O. Box 594, Frankston. 3199  
Phone: (03) 783 6604

# C.A.E. ELECTRONICS PTY. LTD.

## SYDNEY'S LEADING EPSON COMPUTER DEALER

For solutions to your Small Business problems, talk to the professionals at CAE for expert advice on the BEST Hardware & Software in the industry.



# EPSON QX-10

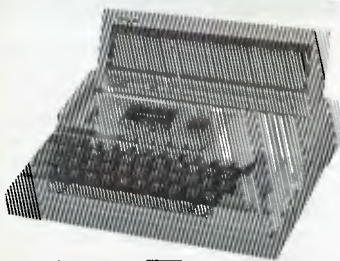

Prices for the QX-10 start at **\$2900** (\*ex. Tax). A full range of peripherals is available including 10-40 mB Winchester disks, Local Area Networking, IEEE 488, Optical fibre communications, A/D & D/A converter, and Much More.

- RS 232C Port : Light pen interface
- Centronics parallel port
- Colour option available
- S-slot expansion bus
- Fast voice coil motor disk drives
- 256 K RAM : 2 x 320K drives
- 640 x 400 dot graphics
- Real-time clock & calendar
- 2 x RAM drives : Battery backup
- 16 character fonts

We offer the BEST After Sales Support possible.

**PX-8**

**\$1235**  
(\*ex. Tax)



**1/27 FORGE STREET, BLACKTOWN, (02) 621-4242**  
**P.O. Box 62, BLACKTOWN, NSW 2148 (02) 671-6951**

# Fast talkers with all the right answers

*MultiModem and MiniModem use the latest VLSI technology. Digital signal processing achieves functions normally requiring analogue filters. The result? Reliable data transfer on lines where most modems just won't go!*

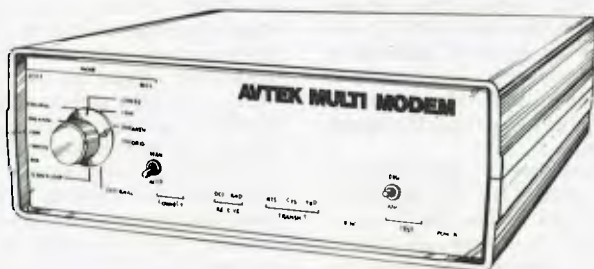

## MultiModem only \$349.00 inc. phone

*Down the street or across the world, MultiModem speaks the language.*

- 300 baud full duplex, 1200 baud half duplex or 600 baud half duplex, answer or originate.
- CCITT and Bell standards
- Autoanswer and connect ability
- Plugs straight in (hardwired phone)
- Superior VLSI chip performance: works reliably with -43dBm signal with S/N ratio of 6dB. Error rate on this level is 10<sup>-5</sup>!
- Telecom Approval C84/37/1135



## MiniModem only \$199.00 inc. phone

- 300 baud full duplex
- Answer/originate
- Plugs straight in (hardwired phone)
- Superior VLSI chip performance (identical to MultiModem).
- Telecom Approval C84/37/1173

## AVTEK

(Electronics) Pty Ltd  
119 York Street Sydney 2000  
Phone (02) 267 8777

Mail Orders: PO Box Q302, Queen Victoria Building, Sydney 2000

Goods expected in stock and prices correct at time of going to press.



P&P on modems is \$7.50 (registered)



# MicroBee Games



## BUNYIP ADVENTURE

Are you tired of adventures set in unfamiliar exotic locations? Well, now there is a truly Australian adventure set in our sunburnt outback.

The aim is to catch the bunyip and on the way you will encounter no end of Australian flora, fauna and folklore. Can you catch the jumbuck by the billabong? What is the significance of the black stump? And what was that swagman doing by the coolibah tree? As night approaches and you boil the billy, you hear the howl of the dingoes as the bunyip approaches. Will you be able to catch him?

**\$20.00**

## GROTNIK WARS

*Grotnik Wars* is a high-speed three-dimensional video-game set in the surreal wastes of deep space. *Grotnik Wars* is more a simulation than a game. All objects conform to the laws of physics. You control the acceleration of your space ship.

What you see on your screen is what you would see if you looked out of a window of a space ship. In the background, the stars of the universe beyond provide a reference for your movement. Asteroids drift past eerily. A cluster of star dust floats by. All is peaceful. Suddenly sights appear on your screen. A fighter screams past and in the distance you see dots. You move forward to take a closer look. More sights appear on your screen as the enemy approaches from behind. As you accelerate to maximum speed you are thrust into the tumultuous crucible of a full-scale space-battle.

*Grotnik Wars* is uniquely inventive in the situations that it presents to the player. Even the author, after weeks of debugging and testing, still plays it and finds it challenging. He's hooked!

**\$20.00**

Order either or both of these exciting programs by sending a cheque or money order to:

Grotnik Software  
P.O. Box 372  
Glenside 5065.  
South Australia.

POST FREE. NO CREDIT CARDS.

**GROTNIK™ SOFTWARE**

# NEWS



## Star Wars comes to Education

COMPUTERS and education are really taking off together. A company called Command Performances, which specialises in educational theatre, is staging the Star Wars Computer Education Show in schools throughout the Sydney metropolitan area — with the sponsorship of IBM Australia.

Hailed as "one of the most innovative projects in Australian computer education", the show comprises three parts and combines the charisma of the Star Wars characters with computer technology and personal computers, all under a giant portable space dome.

The first part of the show is an exhibition of computers demonstrating robotics, voice synthesis, video control and graphics. Next is a display of 40 IBM Personal Computers specially programmed to allow the

audience to experiment and learn for themselves just how computers work. The third part of the show, which incorporates the Star Wars characters, is a half-hour play.

Managing Director of Command Performances, Ken Copeland, explains that the company aims to examine the difficult areas in education and 'sugar coat' them to make them more palatable. He says, "We're on about motivating kids and teachers to tackle difficult areas, and computers, because of their newness, fit into this category." IBM Australia's Director of Technical Operations, Tony Bowra, who has been a driving force behind the project from the start, feels the show provides a good vehicle for increasing people's awareness of the beneficial effects of computers. □

## Just to set the record straight ...

IN THE August issue we reviewed the Atari 800XL, and while we found it generally a good machine, we did get a couple of facts slightly askew and would like to put the record straight.

Greg Every, a representative of Futuretronics, the Australian distributor for the Atari, has informed us that we were incorrect in specifying the screen resolution at 160 by 192; Futuretronics defines the resolution as 320 by 192. In our review we had actually said we would have expected better resolution from a machine like this, so while we're sorry we made the mistake, we're very pleased to hear the extra resolution is there.

Greg also pointed out that the Atari XL range provides 256 'colours' from 16 basic colours at 16 different intensities. Our review stated that you only got

16 distinct colours; we neglected to mention that the 16 intensities in fact result in 256 distinguishable shades of colour.

Greg was also able to help out with the processor. After our reviewer had torn shreds of skin off his knuckles trying to find out from inside the machine what beast was driving it, Greg informed us that it is a 6502, and that the ROM is 24 Kbytes, with 16K for the operating system and 8K for the BASIC.

We're sorry if our omission of these details annoyed 800XL owners, who no doubt regarded us as simpletons for not having discovered such basic facts. However, even without them our review pronounced the machine to be a good, general-purpose, easy to use and fairly powerful computer; knowing these extra facts, we have to say it must be even better than we thought then! □

# ONE TOUGH SPELLER.



Learning comes alive with **DesignWare™** because every program is loaded with fun and excitement for the whole family.

We've combined sound educational content with the kind of versatile fun games you and the kids will want to play over and over again. Children build skills important to their school progress, while enjoying the exciting colour graphics, sound effects and animated teachers and creatures. Adults can play the games to refresh their skills or just for fun with the family.

All programs for ages 4 — Adult, developed by educational experts — tested by kids & teachers. All programs with full on-screen demonstrations.

**SPELLICOPTER    CRYPTOCUBE    SPELLAKAZAM**  
**CREATURE CREATOR    TRAP-A-ZOID    SPELLAGRAPH    MATHMAZE**

All priced at only  
**\$49.95**  
inc. tax



**EDUSOFT**  
EDUCATIONAL SOFTWARE  
Tel: (02) 451-6243

**See your Apple/IBM/Commodore dealer NOW!**

For further details/trade enquiries send the coupon below.

Bulk Orders — Mail Order direct to Edusoft.

**Dealer Enquiries Welcome**

All software carries a 7-day unconditional Money Back Guaranty; Satisfaction or immediate refund.  
All software warranted for 30 days — Unconditional. Back-up copies available for all systems — only \$10 each

To Edusoft — P.O. Box 252 Forestville, N.S.W. 2087.

Please send my FREE catalogue and more details on:.....

Name:..... Address:.....

Postcode:..... Telephone:.....



# FRESH SOFTWARE DAILY!

We're not kidding either. So much new material is being written for the COMMODORE C64 (that's because it's the biggest selling computer) that we release new programs daily — or most days anyway.

There are powerful new programs to run your business, educate yourself, or family and have fun with.

We have a lot of them.

The *friendly* Computer Spot Commodore has more.

Call us now for low prices.



*the*  
**Computer Spot**

MLC CENTRE: Martin Place, Sydney, Phone: (02) 235 2971.  
EASTGATE CENTRE: Bondi Junction, Phone: (02) 387 5208.

THE MAT CS2098

## NEWS



### Magnum in Doubt

THE Dulmont Magnum, the Australian designed and manufactured lap sized portable, appears to be in trouble. Seventeen employees have been retrenched from the company and marketing director Terry Crews has taken extended leave while other executives have not been

available for comment.

The production of Magnums may be around the 100 per month mark, with occasional spurts to 200. There may also be problems with chip availability, as the Magnum uses a CMOS 80186, a very popular chip known to be in short supply.

### Economic Computer Graphics

SOUNDCRAFT Network Video, a British company, has released a low-cost modular computer graphics system called Image Artist. The system is said to bring sophisticated video effects within the reach of many designers, at less than half the price of most comparable existing equipment.

Using an electronic stylus on the touch-sensitive digitising pad, the designer can display at the top of the monitor screen a palette of 256 colours from a potential store of over 16 million different shades. The stylus also controls the computer's cursor to select any brush style and size, in addition to a large range of special effects, shapes, or high-quality, laser-set typefaces.

The computer offers a menu to the operator and then follows

a logical series of options and instructions to obtain the best possible results. At any stage in the design, the image on the monitor can be stored on disk or added to using stored artwork or photographic images, overlays, colour shading and 3-D effects. By mixing still frames from the disk store with live signals, the system can also be used for studio graphics during transmission.

The basic Image Artist package includes the computer and keyboard, floppy disk drives, frame store, 38 cm digitising pad with electronic stylus, and monitors for computer functions and artwork. The monitors are optional as the system could be linked to a designer's existing screens if preferred.

More information is available from Soundcraft Network Video, Old Ryde House, 393 Richmond Road, Twickenham, Middlesex, England; phone 01-891 4941.



# When you can't afford mistakes.



There really is a difference in diskette brands.

It's in the way they are made.

Because the computer industry cannot afford variation in the quality of diskettes, at Nashua we looked for, and found a way to ensure absolute consistency.

Here's how we do it.

### Quality Circles.

At Nashua we've found the best way to attain this 'consistency' is to ensure that at each stage of production our diskettes



are statistically checked to make sure the quality is 'built-in' every step of the way.

Rather than long production lines, we have 'Quality Circles' – small groups of people whose job it is to make sure that each Nashua diskette is right in the first place.

The result is a diskette with such consistency, that it is chosen by those people who can't afford mistakes.

Phone Sydney 958 2044,  
Canberra 47 0511,  
Melbourne 428 0501,  
Brisbane 369 4244,  
Adelaide 42 0021, Perth  
328 1888, Darwin 81 6204,  
Auckland 77 5468,  
Wellington 85 1965,  
Christchurch/Dunedin  
Whitcoulls Ltd, PNG  
25 6766.



There really is a difference.

# Insure your computer against costly accidents and breakdowns.

'Computer Shield' — the Insurance Cover and Service Plan to safeguard your new computer against the unexpected.

Unfortunately malfunctions, breakdowns and silly accidents do occur. Computer Shield is your safeguard against costly repairs and the inconvenience of being without your computer.

## The Computer Shield Insurance Cover:

Protection against any loss or damage from sudden or unforeseen circumstances, including:

- Mechanical and electrical breakdown
- Malicious damage
- Accidental damage
- Storm, lightning, water, flood, explosion and impact damage, fire, or
- New Computer and Peripherals, and:
- Selected used Computers & Peripherals

## Service Plan:

- A twelve month service/maintenance program during the period of insurance by an Authorised Computer Technician, to ensure that minor problems don't become major disasters.

## In addition:

Computer Shield covers you for:

- Labour costs involved in repair/replacement
- Hire Costs or replacement computer facilities
- Re-keying labour costs from duplicate disc or prior week's hard copy



Computer Shield — Insurance Protection for computers.

Phone Wendy now on (03) 51 5242, or see your authorised Computer Shield dealer for more information or send the coupon below.

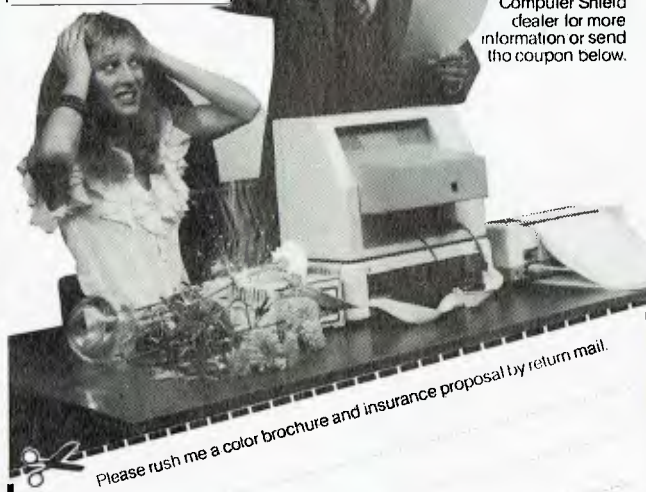

Please rush me a color brochure and insurance proposal by return mail.

Name .....

Company .....

Address .....

Telephone (STD) .....

PCode .....

WFOOD 373/CS

## Queensland Computer Show

THE Crest International Hotel, Brisbane, is to be the site of the second annual Queensland Computer Expo in November this year. The success of last year's Expo has encouraged the organisers to broaden the scope of the show, and exhibits this year will include both mini and microcomputers, together with peripherals and software. This means there will be something to interest both the business community and the general public amongst the many

displays.

According to the organisers, every major manufacturer of computer equipment will be represented at the show, including IBM, Hewlett-Packard, NEC, Wicat, Data General, Sanyo, Apple, Commodore, Dick Smith, Atari and Microbee.

The Expo runs from November 8-11, and more details can be obtained from the organiser: Robert Woodland, 50 Sherbrooke Road, Acacia Ridge 4110; (07) 372 3380.

## Commodore Drives Recalled

ALL 220 volt MSD disk drives for Commodore computers sold by Chambers Computer Supplies of Monkhouse Drive, Endeavour Hills, Melbourne, or their dealers have been recalled.

It has been found that the 220 volt model, originally intended for sale in South America, can lose data with some programs if run on 240 volts and is highly sensitive to 'spikes' on the power lines.

Anyone who has a 220 volt model should return their drive, together with the instructions and other documentation that came with it, to the dealer from whom they bought it, and it will be replaced free of charge with a new machine and a guarantee for the unexpired period of the twelve months. The new model contains a 240 volt isolating transformer approved by the state electricity authorities.

## TI Portable and Network

TEXAS Instruments recently released a portable computer, fully compatible with the desktop TI Professional Computer, and offering the same high-resolution graphics, colour capability, memory expansion, internal modems and keyboard as the TI Professional.

Because the new Portable Professional is totally compatible with the original model, an extensive software library and numerous hardware options are available. For example, MS-DOS, Lotus 1-2-3, and TI's Speech Command system will all run on it. Other features include a 16-bit 8088 central processor, a minimum of 128K of RAM expandable to 768K, five expansion slots, and an integral 13 cm half-height floppy diskette drive with space for an additional built-in disk drive option. Storage capacity of an individual floppy diskette is 320K under MS-DOS 1.1, and 360K with MS-DOS 2.1.

With monochrome display the TI Portable costs \$4280; with colour, \$5530.

The Portable connects, as do all other members of the TI Professional Computer family, to TI's new Etherseries of local area network products. Since Ethernet is endorsed by more than 60 computer manufacturers, it also provides connections with many different brands of personal computers, minicomputers, mainframes and other data processing equipment.

Recommended retail prices for Etherseries products are: \$1500 for Etherlink hardware; \$150 for user software; \$650 for EtherShare; \$750 for EtherPrint; and \$900 for EtherMail.

For more information, contact Texas Instruments at PO Box 106, North Ryde 2112, (02) 887 1122; or at 418 St Kilda Road, South Melbourne 3004.



## Webster's Pint-Sized Mini

PRISM is a new multi-user minicomputer family released by Webster Computer Corporation, pioneers of Australia's indigenous computer industry. In keeping with the company's design philosophy, the new computers incorporate big technology in a small package.

Taking twelve months and \$500,000 to design, Prism houses a PDP11 computer, hard disk and back-up drive in a desktop visual display terminal, occupying little more space than a micro. There is a choice of three DEC processors – the 11/2, 11/23 and the 11/73 – and

all DEC standard operating systems, including UNIX, RSTS, RSX11m+ and TSX plus, will run without modification.

Prism is designed to fill what is seen as a gap in the market between top-range micros and the more expensively priced minis. The system comes with 64K of memory, expandable to 1M, and a choice of 10M or 21M (formatted capacity) Winchester disks. Up to eight terminals may be attached, creating a multi-user/multi-tasking environment.

Software for the system includes integrated accounting, word processing, spreadsheet, graphics and database, and vertical market applications such as medical, dental, legal, hospital, rural and communications. Systems begin at \$11,800 for an 11/2-based, 10M system and \$15,000 for the base 11/73 CPU model.

For more information, contact: Webster Computer Corporation, NSW – (02) 922 2011; Vic – (03) 729 8444; Qld – (07) 208 1533. □



## Labtam goes to China

LABTAM has signed the first of five major deals with the People's Republic of China, and will be supplying \$1.68 million worth of Labtam 3000 Series computers to the Anhui Province government over a nine-month period.

The computers are destined to be built into Chinese-made conveyor belt systems. While the first batch of machines will be built and assembled at Labtam's factory in Victoria, the second batch will be exported in kit form for assembly in China.

The directors of Labtam, Heimo Eberhardt and Don Dryden, have also agreed to sell 32 per cent of Labtam International to the licensed management and investment firm established by the Pratt Group. The seven-figure investment will be partly used to boost domestic sales.

In *Pacific Computer Weekly* Eberhardt was quoted as saying, "About 70 per cent of sales are from exports. It has got up as high as 85 per cent. That makes me very nervous, because you can't debug or prop-

erly look after new developments without a big home market." He said he felt the ideal mix of domestic to export sales would be 40:60, or even 50:50. He believes the changed climate, especially the Federal Government's willingness to buy Australian, would help domestic sales of Labtam computers. □



David Tam demonstrating the Labtam.

## The M-1009 printer.

METROPOLITAN Business Machines has begun distribution of two lines of Brother printer.

The M-1009 is a compact dot matrix printer capable of printing text and graphics at up to 80 columns. Resolution can go as high as 960 points horizontally by eight characters vertically per line. It has friction and pin-feed options and measures 333 mm by 191 mm by 70 mm.



## New Printer Distributor

The BP-30 is a combination typewriter and colour printer/plotter. Programmed for up to eight different graph and chart configurations, each one capable of 12 selectable variables, the BP-30 has battery power so it can be used anywhere. It measures 337 mm by 266 mm by 67 mm and weighs 2.7 kg.

Metropolitan Business Machines is at 338 Sydney Road, Brunswick 3056. □

## Briefly . . .

■ *Hewlett Packard Australia has launched a new package, HPTelex, a hardware and software package that lets HP3000 users compose and transmit telex messages from most HP terminals. The hardware is Telex Interface Unit from Case Communications and the software, HPTelex, is available from Hewlett Packard offices in all states.*

■ *Hanimex has brought out a shoebox-sized cassette recorder specifically for use with microcomputers. It features DIN sockets and standard jacks, auto stop, tape counter and pause function. It costs only \$46. For more information contact Hanimex, 108 Old Pittwater Road, Brookvale 2100.*

■ *AT&T has signed an agreement to support Microsoft Windows on its new PC 6300 personal computer. The windows feature provides a universal standard for bit-mapped applications programs. AT&T has also announced plans to offer the MS-DOS operating system, GW-BASIC, Microsoft Word and Microsoft Multiplan.*

■ *Fingerprint recognition by computer has been developed by UK software company Logica for Scotland Yard and the London metropolitan police*

*force. The system compares fingerprints at the rate of one million per day. It costs \$3.5 million and can store 650,000 fingerprints and 100,000 body marks in databases.*

■ *Software from computer entrepreneur Adam Osborne is due for release this month from Osborne's new company, Paperback Software. Packages should include a full-featured word processor, elementary word processor, electronic spreadsheet, typing tutorial and business graphics. The packages are at present being sold in US bookstores and supermarkets, while in Australia traditional markets will be used initially, with extension to other outlets a possibility.*

■ *Datronics has announced the acquisition of 90 per cent of Victor Technologies, the troubled manufacturer of the Sirius range and other computers. Chuck Peddle, founder of Victor, has supported the move, which will help Victor to get out of the Chapter 11 protection for which it has had to file for protection of creditors. The sale will help Datronics, a Swedish firm involved in distribution of the Commodore range, to establish a foothold in the US market where it hopes to get a 0.5 to 1 per cent market share.*

RITRONICS

WHOLESALE  
PTY LTD

# COMPUTER WAREHOUSE

48-50 A Beckett St., Melbourne (03) 347 7917

For one month we are going to supply the goods below at these fantastic prices. The offer extends to mail order and cash and carry customers. If you know what you want then this is the way to buy it. Naturally at these prices we can't afford to spend a lot of time demonstrating the product, but, if you want to save money then it will be worth your while to miss out on a demo. We have the long experience in the computer and electronics industries to back up what we sell. We are not a backyard organisation, nor are we squeezed into one tiny shop that's more appropriate for a milkbar than high tech products. We have two established retail outlets, a large wholesale organisation as well as several warehouses. And that's where this sale comes in. The goods come straight from our warehouse to you. That means you may have to wait a day to get your gear, and save your money. To organise your goods phone 347 8066 or call in at our city store upstairs at 48 A Beckett Street. Yes we take Bankcard.

## THIS MONTH ONLY!

### PRINTERS

#### MICROLINE

Microline 83P.....	\$828
Microline 83S.....	\$984
Microline 84P.....	\$1230
Microline 84S.....	\$1338

#### C. ITOH

C. Itoh 8510sp 180 cps.....	\$750
C. Itoh 1550sp 180 cps.....	\$1021
C. Itoh 8510sc (colour).....	\$920
C. Itoh 1550sc (colour).....	\$1090

SX80 — \$259 + tax

#### STAR

Gemini 10X.....	\$360
Gemini 15X.....	\$600
Radix 15 200cps.....	\$1295

#### JUKI

6100P 18cps.....	\$700
6100S 18cps.....	\$820
8K Buffer fitted.....	\$75
TRACTOR FEED.....	\$180
SHEET FEED.....	\$570



### PAPER PAPER PAPER PAPER

Boxes of 2000 sheets 70 gsm with keen edge perforations. Excellent quality 10" paper. you won't beat this price

1-4 boxes.....	\$24 00
5-10 boxes.....	\$22 00
10-20 boxes.....	\$20 00
20+ boxes.....	\$18 00

All prices are subject to sales tax.  
All goods subject to prior sales  
and deliveries. Normal three month  
warranty applies to all products.



Errors and Omissions Excepted

48-50 A Beckett St., Melbourne (03) 347 7917

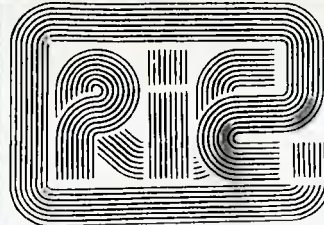

### MICROBEE

DISK SYSTEM for Microbee 16K and 32K with CP/M like operating system and utilities. Runs CP/M software. 400K drive. Operates from Microworld Basic as well.

Only Mytek could have produced this excellent software.

SINGLE DRIVE SYSTEM

DUAL DRIVE SYSTEM

ADD ON DRIVE

NEW PRODUCT

\$780.00

\$1100.00

\$329.00

## ★★★★ BARGAIN ★★★★★



WORDSTAR.....	\$400
MAILMERGE.....	\$250
SPELLSTAR.....	\$250
CALCSTAR.....	\$150
SUPERSORT.....	\$200
CARDBOX.....	\$250
WORDMASTER.....	\$200

SOMEONE WENT BROKE, WE  
PICKED UP THE PIECES, YOU  
REAP THE BENEFITS.

CPM 80

All software are original licensed versions with manuals.  
Limited stocks available. First come, first served basis.  
Wordstar Mailmerge Spellstar Wordmaster and  
Calcstar are Trademarks of Micropro Corporation USA

### EXCALIBUR

\$595

#### NEW PRODUCT

Excalibur is alive and well  
kits now available

This stunning design with excellent  
colour BASIC in RCM and a host of  
features is now available as a kit \$595

Z80A CPU. 3.5 MHz 64K RAM. 16K  
ROM RF output. Direct video output  
and RGB. QWERTY Keyboard  
Cassette Interface built in. Serial  
RS232C Parallel. 8 bit centronics  
Color 16 foreground and 8 back-  
ground colours. 24 lines by 80 charac-  
ters 7 x 12 dot matrix (monitor  
required)

### Memory

Huge range best prices

Direct Import saves you money

	1	10+
2114	\$2.50	\$2.00
4116	\$2.95	\$2.50
4164	\$9.00	\$8.00
6166	\$8.00	\$7.50
2716	\$5.90	\$4.90
2732	\$6.90	\$5.90
2764	\$8.90	\$8.50
27128	\$39.00	\$37.00

### Verbatim Discs

525-01	32.50/box 10
550-01	47.00/box 10
34-4001	50.00/box 10

6502 ADD ON DRIVES

\$265.00

(Drive Only)

\$285.00

(Drive & Controller)

### Japanese Mechanism

3 Months Warranty

DP80/CP80 RIBBON

RIBBONS	1	10+
	\$11.00	\$9.50

### TRY OUR GREAT RANGE OF MONITORS

RITRON I



Our most popular Model in a  
steel cabinet for less interference  
AMBER \$199.00 GREEN \$189.00

### RITRON III SWIVEL BASE

Great resolution for those who want a little more quality AMBER \$219.00

## ROD IRVING ELECTRONICS

Mail Order and Correspondence  
P O Box 235 Northcote 3070

Cert. post for orders over \$100 included free  
Reg. post for orders over \$200 included free

Minimum of \$3 for postage and packing.

Account orders from schools, govt depts, public co's, gratefully  
accepted. Min order amount \$20.00 (or a min. \$5.00 accounting  
charge will apply). Comet Road Freight, Airmail etc. are extra.

Mail Order Hotline



(03) 481 1436

**T**alk to anyone involved with computers these days, and they'll tell you that the most exciting area of development is communications: computers 'talking' between friends and groups of people, within companies and institutions, and even across the world. If you've never done it, it sounds mind-boggling, but all sorts of computer novices have started off nervously communicating, and in no time at all found themselves 'conversing' with people all over the country as if they were old friends on the telephone.

At the personal level, communications are relatively simple, as you'll see from articles in this issue covering such topics as bulletin boards, modems and access to databases, both overseas and in this country. Most personal computers, even the smaller ones owned by many hobbyists, can support this kind of communications, and their owners can therefore both 'talk' to each other (through bulletin boards and the like) and obtain cheap and easy access to up-to-date information from databases around the world.

Things become more complex if you're a member of a large company or corporation using a personal computer, and want to communicate with your organisation's mainframe or minicomputer, perhaps to get hold of some data and work on it. A difficulty here is that most mainframe files are far too big for a PC to cope with, and that suitable software to remove the relevant bits you want doesn't always dovetail very well with your micro's normal operation. However, progress is being made in this area, with packages like Tempus Link starting to make this kind of operation much easier to perform.

If an organisation wants to connect together a system of microcomputers, the best way is probably through some kind of local area network. These are fairly complicated and expensive to install, but have the benefit of operating quite simply and being available from several suppliers. In a local area

network, all the PCs are able to share files, which are usually kept on a central 'file server' (a machine dedicated to managing the system's files), and limits can be set on which users can gain access to which files through various security measures.

Many network systems support useful facilities like electronic mail or the ability for several micros to share a printer or a hard disk, and for applications like office automation they're probably the way of the future. However, for other applications, such as where several people share a set of accounting files, the software as yet hasn't been developed for LANs to sort out which user is doing what to which part of what file at any one time. We'll be discussing local area networks in detail in our November issue, in which we're continuing this feature on data communications.

The next step up from local area networks is the wide area network, of which the best-known example is the telephone system (in a sense). Direct communications between computers is now possible through the Telecom Austpac system (again, more on this in November), which is a network based on the almost-international X.25 protocol, such systems are removing both the expense and the difficulty from such wide area communications.

If you have any kind of micro, communications is an area you shouldn't ignore, as its potential for both usefulness and fun is expanding virtually every day. In this issue we'll be bringing you up to date with the practicalities of communications with our look at modems, with the people you can 'talk' to by a discussion of RCPMs and bulletin boards, and with the kind of information that's accessible from your computer in our article on databases. Next month we'll broaden our horizons to cover local area networks and the Austpac system – communications is such a big area we couldn't cover it properly in one issue!

Now read on ...



# DATA COMMUNICATIONS

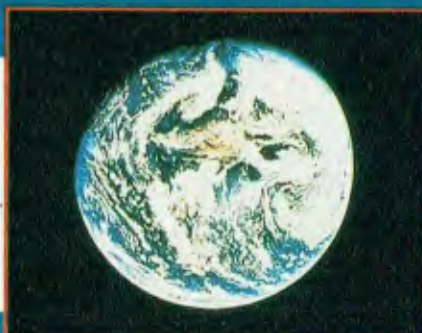

*Into the  
future . . .*

# Remote Databases

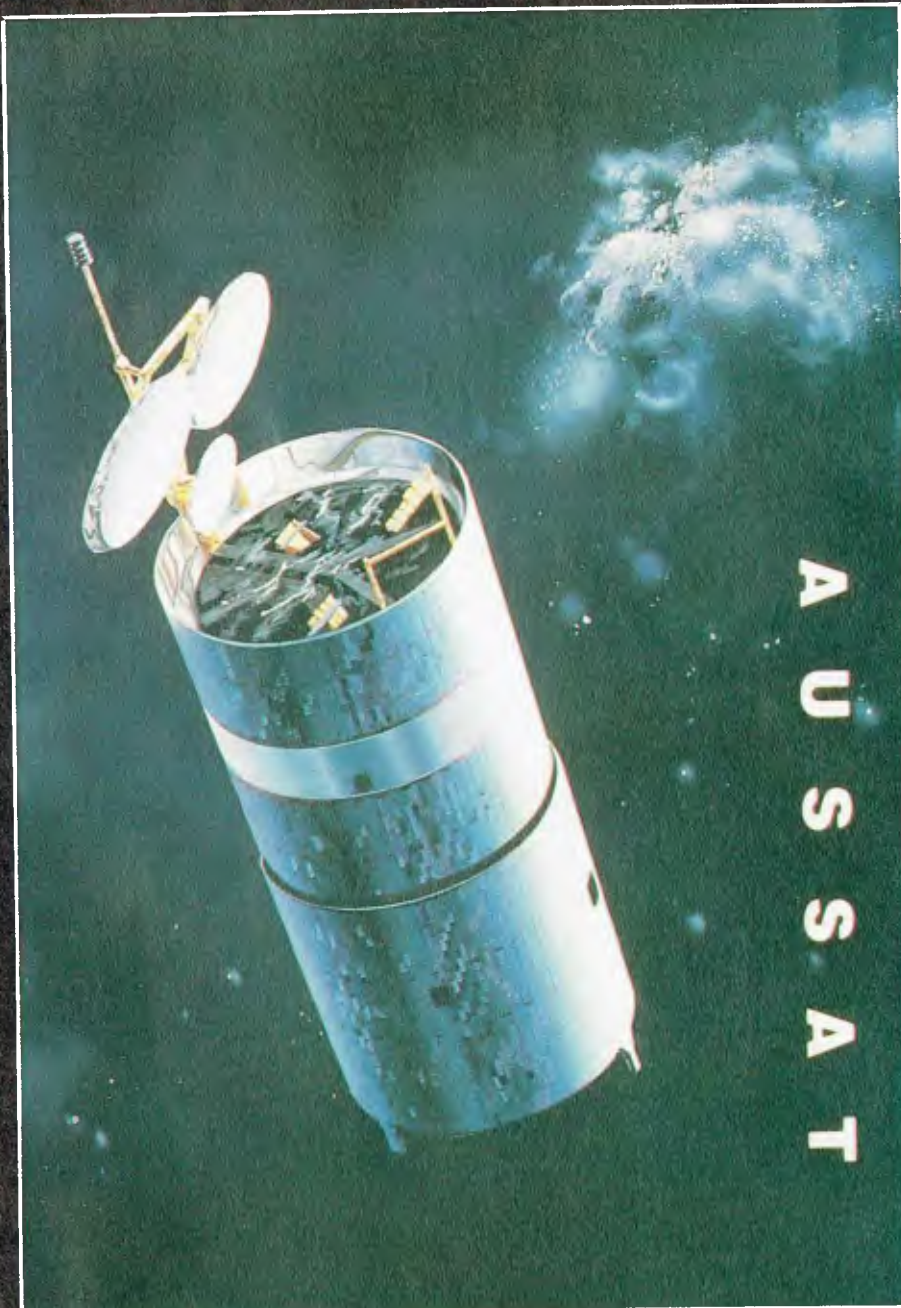

THE INITIAL development of remote databases was, like so many other good ideas, the offshoot of a different process altogether – the use of computer phototypesetting for the production of indexes and other reference publications.

The economics of publishing was responsible for vast amounts of data being captured in machine-readable form, but it was the development of rapid-access, relatively cheap, mass storage devices which made it feasible to store all this data for re-use. With the advent of powerful time-sharing computers which permitted simultaneous interaction with files by a number of users at remote locations, the necessary hardware for exploiting this ever-growing collection of information was assembled.

Add to this the availability of telecommunication networks such as OTC's MIDAS, and domestic carriers such as Telenet, Tymnet and Austpac, providing dial-up communication facilities at a lower cost than the telephone network, and you have the basis of a vast information network.

The critical factor then is appropriate software to interact in a meaningful way with the databases. This has been an area of a great deal of research, and current search software, while not generally considered to be user friendly, allows combinations of concepts, and terms and query refinements through the use of Boolean operators (AND, OR and NOT). A whole range of query types can be accommodated from the very simple to the extremely complex.

Finally, the availability of microcom-

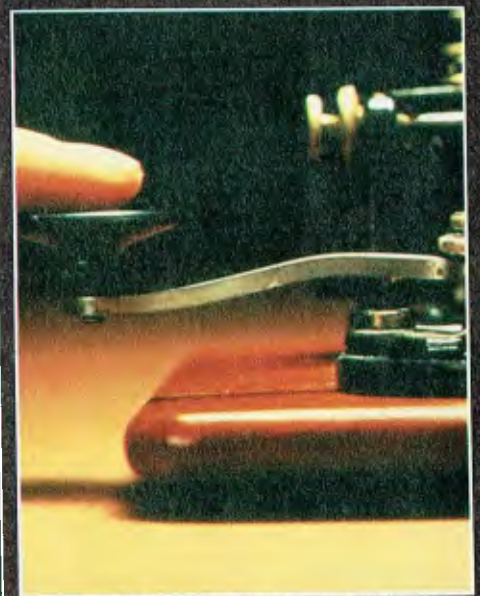

puters with communications capability, at affordable prices, has meant the individual can access this storehouse of information himself.

Databases come in every size and subject. Some are geared specifically to the researcher. Can you imagine a file of over six million references which is updated by 20,000 references a fortnight, and all on chemistry? INSPEC with a mere two million plus references may be more comprehensible, or perhaps we should start further down still. Magazine Index covers about 400 popular US magazines and contains references to articles, features, product evaluations, biographical pieces, short stories, recipes and so on. The full text from articles in fifty of these magazines is included too.

On the Australian scene, the Australian Public Affairs Information Service file contains citations to scholarly articles, books, conference papers, newspaper and magazine articles on Australian economic, social, cultural and economic matters. Or there is the Australian Business Index which indexes the Australian financial press.

These are all examples of one type of database, the reference database, which contains citations, sometimes with an abstract, to books or articles or other publications. A search of one of these results in a list of citations on the chosen topic. To get the full information requires a trip to your friendly local library to locate the original item, or sometimes you can order a copy through an on-line ordering system.

However, there has been a tremendous upsurge in the numbers of a different kind of database, which can be called the source type. These contain all the original data, so reference to further documents is not required. The data itself can take various forms: it can be purely numeric, it can be encyclopaedic or handbook-type information, or it can be the full text of an item.

Numeric data is often in the form of time series; for example the Australian Bureau of Statistics' economic and financial time series (ABS Time Series and ABSDATA), or the Australian School of Management's corporate data file. Other source databases contain digests of legal cases ('Cases'), the full text of journals, newspapers and magazines ('Popular Science'), news digests ('Facts on File'), or special interest material such as movie reviews ('Cineman Movie Reviews').

A conservative estimate of the number of remote interactive databases puts it at well over 2,000. Knowing what database will be useful for a particular purpose, how to link up with it and then how to search it is a daunting prospect for the novice seeker of on-line information.

The situation has been helped to some extent by the emergence of a feature of the information industry – the on-line service vendor. These public-spirited, usually commercial operations help the on-line searcher by mounting a number of databases on one computer, under one set of software. Each on-line vendor, of course, requires different protocols to

access its suite of databases. Some of the better known vendors are Dialog, Orbit, BRS, Compuserve and The Source in the US; Pergamon-Infoline, ESA-IRS, Telesystemes-Questel and INKA in Europe; IP Sharp in Canada and Ausinet here in Australia. A useful guide through the maze is Cuadra Associate's *Directory of On-line Databases*.

Until the advent of the microcomputer, remote databases were largely the province of librarians and information specialists, who had been specially trained in the nature and idiosyncrasies of databases and search languages in order to retrieve information cost-effectively. The high costs involved, the multiplicity of potentially useful files, and the unfriendly software made this essential. Recognising that the opportunities for gaining this level of skill through formal training and frequency of use will not be available to the average micro buff, greater attempts are being made to render the systems more user-friendly. Two of the larger vendors, Dialog and BRS, have introduced services, Knowledge Index and BRS/After Dark respectively, which provide for a simplified approach, at cheaper off peak rates, to a range of databases thought to be of most use at home.

Growth in the demand for information access through use of personal computers is likely to encourage the proliferation of source databases and developments in easy-to-use software. Videotex, still a relatively unknown factor, could have an important role in the future provision of all kinds of information direct to the consumer. □

*A conservative estimate of the number of remote interactive databases now available to computer users puts the total at well over 2000. These range from files with over six million references that are updated by 20,000 references every fortnight – and all on the subject of chemistry – to small special interest databases on such subjects as movie reviews. Research librarians specialising in remote access material can guide you through the maze if you have such special needs, but the average computer user can find material of use and interest in the most well-known databases like the Source, Dialog, Compuserve and others.*

# PC PRODUCTS

## PC SWITCH

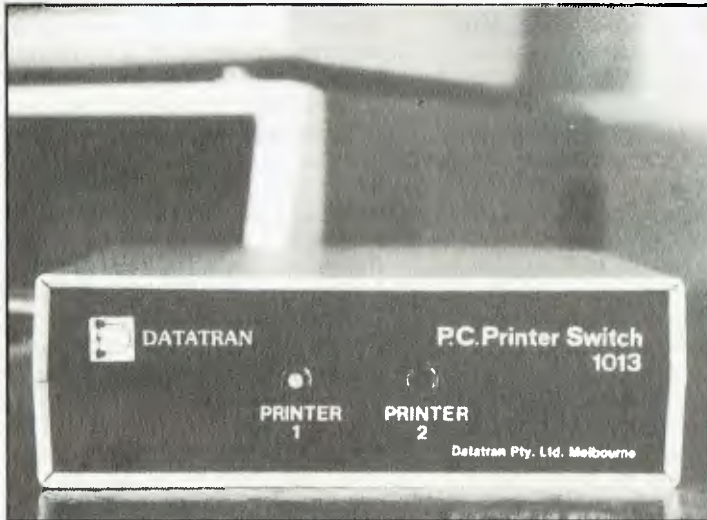

Tired of plugging and unplugging cables to your printers, modems, etc? The **PC SWITCH** products provide rapid selection of the required device at the touch of a button! Simple to instal, you need never tangle with cables again!

Developed specially for Personal Computers, all switches come with friendly instructions:

**Model 1013 Printer switch.**

**Model 1023 Universal switch.**

**Model 1033 Communications switch.**

## PC CONVERTER

The PA-1000 protocol converter allows your PC to emulate an IBM 3278-2 terminal. Virtually any Personal or Portable Computer can utilise the PA-1000 to emulate the 3278. IBM, APPLE, DEC, TRS80, KAYPRO, COMPAQ, NCR, EAGLE, and others. The PA-1000 also connects to the DEC VT100, IBM 3101, LSI ADM5, Televideo 910 and ADDS Viewpoint.

In addition to the coax connection, the PA-1000 provides an extra port. This gives you access to other local or remote asynchronous host computers or local printers. If you need it, there is an in-built HELP facility to "answer questions".



To find out more about the **PC SWITCH** and **PC CONVERTER** products call us for information and for your nearest PC Dealer who stocks our products.



**DATATRAN**

PO Box 88, Hawthorn 3122.

Telephone: (03) 729 2844.

## DATA COMMUNICATIONS

"I wish, I wish ..." said Frank Lee, and he got a database that he could contact using a computer, modem and telephone line; that he could ask important questions of; and, more importantly, that he could get answers from. The database is the US-based DIALOG, an information retrieval service. Frank accessed it via MIDAS, OTC's international packet switching service.

# Let's Dialog



OTC's Midas logo.

THE CONTENT of my own personal wish list ranges from owning a BMW to being able to see the Microsoft Flight Simulator running in colour on my RGB monitor. Alas, neither seems likely to come to fruition. On the other hand, an item which was high on a much earlier wish list now seems to have been granted by the Personal Wish List Fairy.

It happened roughly like this.

As a doting parent of children, each having passed through the hassles of a high school education, one became particularly attuned to certain threatening words. High amongst these was 'project'. Projects about the Australian Gold Rush, or Seal Hunting in Alaska, or How the Blood Vascular System Functions, or Man in Space, or whatever.

A project has a life of its own. It feeds, spreads, and grows. *National Geographic* magazines are carved up in sacrifice to the project. My *Scientific Americans* and complete collection of *Byte* magazine are locked up for the duration. And there is the library research work, and the photocopying, the careful artwork, the rub-on lettering, and finally the vicarious family reward when the alleged author of the project beams home with an Excellent Work Johnny.

The 'project' is a family affair. Of course, the child expects parental assistance. But perhaps at no other time does one despair more for one's ability to help; and this in spite of our owning the most incredible collection of useful periodicals.

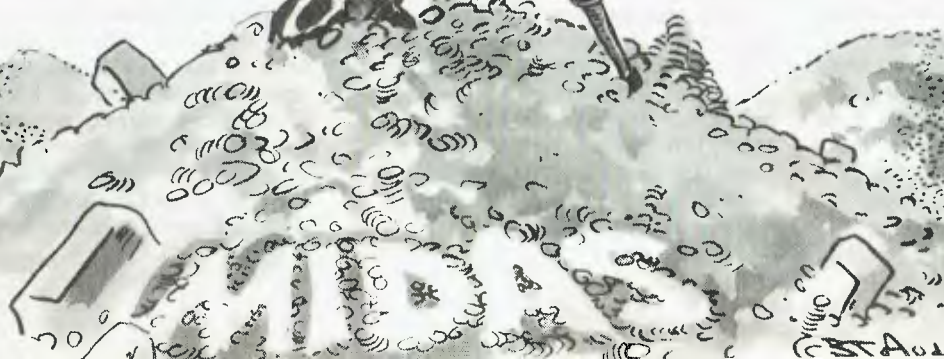

## Let's Dialog

It's all very well having a complete collection of the *Scientific American* magazines from 1966 on. If you don't have an up-to-date index of the thing, you will be driven up the proverbial gum tree looking for that article which you vaguely remember reading which seemed to contain just what was wanted.

And so, there on my wish list was a simple request: a project manager program, perhaps for the Apple II, which would accept a set of keywords and then hunt down the possible references in a database designed just for school projects. I figured that some enterprising company could write the software and specify the format for databases so that other companies might supply a six-monthly or annual update service for particular magazines. High on the list would be the magazines just mentioned, a decade of one per diskette.

I understand that Encyclopaedia Britannica and Grolier are already moving in this field. Perhaps there is still room for an Australian entrepreneur to bring to market such a product. It would sell world-wide.

### Now for the Nitty Gritty

All of which brings me to the subject matter of this article. For if the software is not already available on your favourite micro, let me assure you that it is there and available through the medium of your personal computer and a number of remote database services. A most effective substitute for our personal computer project manager is Lockheed's DIALOG system, which is accessible through Australia's Overseas Telecommunication Commission (OTC). Although DIALOG is by no means unique, it will serve to illustrate the principles of accessing remote database facilities using standard communications methods.

Many of our readers, especially those who use the *Your Computer* Bulletin Board, will already be familiar with the use of various Remote Bulletin Board Systems (RBBs) and Remote CP/M Systems (RCPMs).

For those not familiar with this form of communication, a little introduction may help. First, one must be armed with the appropriate hardware and software. The minimum system is

generally a personal disk-based computer hooked up to a modem. The modem in turn is connected to your telephone line. If your personal computer runs CP/M, or CP/M-86 or MSDOS, then you have an excellent chance of being able to get hold of the appropriate software to make use of that modem. Among programs which do the trick are YAM and MODEM7, both of which are in the public domain. There are commercial programs for these operating systems as well. These include Modem86, Blast, Crosstalk, Relay and Telios.

Many articles have appeared in previous issues of this magazine explaining in detail how to get started in such remote communications. The May and June 1983 issues are both particularly helpful. Many of the facilities offered by communications programs are unnecessary for effective use of DIALOG. In particular YAM and MODEM7 allow for the uploading and downloading of binary and text files with error correcting protocols. All that is required for effective use of DIALOG is a simple program which takes each keystroke and sends it to the modem (which is hooked up to a serial port on your computer), and which displays each character received from the modem on the computer's screen. In other words, all you need is a 'dumb' terminal system.

If you want to save a disk file of your communications with the remote system, then your program had better be able to retain 'conversations' in the main memory. You will need a facility to dump the captured conversation from memory to a nominated disk file. Most communications programs support this option as well. MODEM7 users will use the 'T' (Talk) command with a file specification.

If you have come this far, you should have sufficient motivation to research the articles mentioned above, with a view to getting one of the modem communications programs functional on your machine. If you lack the urge at this stage, then stop reading this article, and go back to your Pacman and Space Invaders. Believe me, communications are well worth the time and effort expended in getting up and running.

Let's now assume that you have appropriate hardware and software. A little later in this article, and for purposes of illustration, I will describe how I use the public domain program MODEM7 running on Harlequin, my tame Datamax (a CP/M machine with a Z80A and twin 20 cm floppy disk drives). The modem is from Dick

Smith (a Dataphone 300 baud duplex modem) hooked to a serial port. At the other end the modem is attached (courtesy of Telecom) to my normal domestic telephone.

### Partner in Communications

The second component of your communications system is someone or something with which to communicate. While you can check out your set-up on one of the local RCPMs or RBBs for zero outlay (apart from the cost of the telephone call), accessing DIALOG is going to cost you, although perhaps not as much as you may expect.

A word about DIALOG. Or perhaps two.

The DIALOG Information Retrieval Service is centred on a very large mainframe system with more than 180 on-line databases requiring gigabytes of storage for over 80 million records. The California-based system is hooked up to the rest of the world via a variety of common carrier network systems such as Tymnet and Telenet. Australian users generally hook in via OTC's MIDAS service, which operates a multiplexed trans-Pacific satellite link to the US networks. Using MIDAS is a lot less expensive than dialling direct using ISD; besides, you'd need a Bell-compatible modem.

DIALOG has been serving customers since 1972. The most common form of record in the DIALOG system consists of a citation with bibliographic information and an abstract referencing a journal, conference paper, or other original source. Some DIALOG databases also hold articles in their entirety, an example being file 647 (MAGAZINE ASAP).

DIALOG databases (or 'files') cover a broad range of interest areas. These include science, technology, chemistry, medicine, engineering, social sciences, business, economics, and current events.

The system is available 22 hours each weekday, as well as some time on Saturday. Remember to take into account that the USA is 18 hours behind Australian Eastern Time.

To become a registered DIALOG user, your first port of call will be OTC. Talk to their Commercial Officer on (02) 230 5000. You may be directed to the proper contact in the USA, or you may obtain the appropriate application forms direct from OTC. There is no start-up fee, nor minimum monthly fee for usage. On receipt of your DIALOG Order Form, you will be sent a unique DIALOG password. OTC will issue you with two additional







# Before you choose your microcomputer, choose your Kaga.

The selection of computers offering the features and price you desire can often be considerable. But the perfect price-performance package in a monitor is much more clearly defined. KAGA. The leading monitor for all types of microcomputer.

KAGA the manufacturers of TAXAN monitors,

serve you with the most advanced and sophisticated Japanese technology, delivering a performance second to none for sharp, crystal clear picture definition.

And, with a price difference you'll notice is more than substantial. A saving that doesn't mean a compromise in quality, but simply you're not paying just for a name.

Monitor	Specifications	Compatibility	Price*
	<b>Green (P31) or Amber (PUL)</b> Monochrome: Video Bandwidth - 20 MHz Min. Horizontal Res. - 800 Dots Horizontal Freq. - 15.75 KHz	All popular microcomputers including <b>Apple, BBC, IBM</b>	<b>Green - \$285</b> Including Sales Tax <b>Amber - \$299</b> Including Sales Tax
	<b>Green (P39) or Amber (PUL)</b> Monochrome: Video Bandwidth - 20 MHz Horizontal Res. - 800 Dots Horizontal Freq. - 18.432 KHz	<b>IBM &amp; IBM</b> compatibles only	<b>Green - \$330</b> Including Sales Tax <b>Amber - \$340</b> Including Sales Tax
	Input Form - RGB/Composite Video Bandwidth - 6 MHz Min. Slit Pitch - 0.63 mm Horizontal Res. - 380 Dots Vertical Res. - 262 Lines Horizontal Freq. - 15.75 KHz	<b>Apple, BBC, Commodore, Microbee</b> and all microcomputers with RGB/Composite output	<b>\$565</b> Including Sales Tax
	Input Form - RGB Separation Video Bandwidth - 15 MHz Min. Slit Pitch - 0.47 mm Horizontal Res. - 510 Dots Vertical Res. - 262 Lines	<b>IBM, Apple, BBC</b> , all <b>IBM</b> compatibles and microcomputers with RGB output	<b>\$645</b> Including Sales Tax
	Input Form - RGB Separation Video Bandwidth - 18 MHz Min. Slit Pitch - 0.38 mm Horizontal Res. - 630 Dots Vertical Res. - 262 Lines	<b>IBM, Apple, BBC</b> , all <b>IBM</b> compatibles and microcomputers with RGB output	<b>\$895</b> Including Sales Tax
	Input Form - RGB Separation Video Bandwidth - 25 MHz Min. Slit Pitch - 0.31 mm Horizontal Res. - 790 Dots Vertical Res. - 400 Lines	<b>IBM</b> (using double high resolution graphics board) and any microcomputer that produces in excess of 750 dots horizontal res.	<b>\$1,135</b> Including Sales Tax

It is also reassuring to know, having chosen your KAGA monitor, that behind you is a full warranty backed by national distribution. An Australia-wide availability which facilitates only the finest in local dealer service support. So your KAGA will continue

to serve not only your current computing needs, but those well into the future.

KAGA. Ask for them at your computer dealer. Distributed nationally exclusively by COLEX Australia.

\* Recommended Retail Price.

**KAGA TAXAN**  
**COLEX**™

7th Floor, 10 Help St., Chatswood 2067. Telephone (02) 419 6588

## Let's Dialog

identifiers: a user number, and a password. Once you are in possession of these three identifiers, you can begin searching. You should also complete and send off the DIALOG Publications Order Form to obtain a copy of the Guide to DIALOG Searching, an essential tool for using the system.

You might also consider attending a DIALOG training course. In Australia, these are administered by Insearch, which can be reached on (02) 264 6344. A 'System Seminar' covers in one-and-a-half days the basics of DIALOG searching.

Let's now assume you are armed with the right hardware, software, and the three identifiers mentioned above. You should also check your bank balance (more on that later). For illustration purposes only, we'll pretend that OTC has given you the User Identifier SHDF848ABC and a password SAAA1684. DIALOG has issued you with the user number 0848JHDW. (These numbers are *fictitious!*)

### Researching a Project

Now, along comes little Mimi with Yet Another Dreaded Project. This time it's on the disposal of nuclear waste

in the oceans. Having now subscribed to the system for some time, we turn up the latest DIALOG Database Catalog, and quickly determine that there are two likely databases: Oceanic Abstracts (File 28), and Pollution Abstracts (File 41). The Catalog tells me that Oceanic Abstracts will set me back \$US73 per connect hour, with 25 cents for each displayed abstract. It also explains that this database covers oceanography, marine biology, marine pollution, ships and shipping, geology and geophysics, meteorology, and governmental and legal aspects of marine resources.

Pollution Abstracts is the same cost per connect hour, but a little cheaper on individual record displays. Unfortunately, it seems to be more concerned with water pollution rather than the more specific concern of Mimi's project - Oceanic Pollution.

Before settling for Oceanic Abstracts (File 28), a nasty thought: most of the records in this file (and file 41 for that matter) will be abstracts of scientific articles which may be just a wee bit beyond little Mimi's noggin. More germane would be the sort of thing which would be written up in the popular press. Better still if there is an article with its full text. File 47

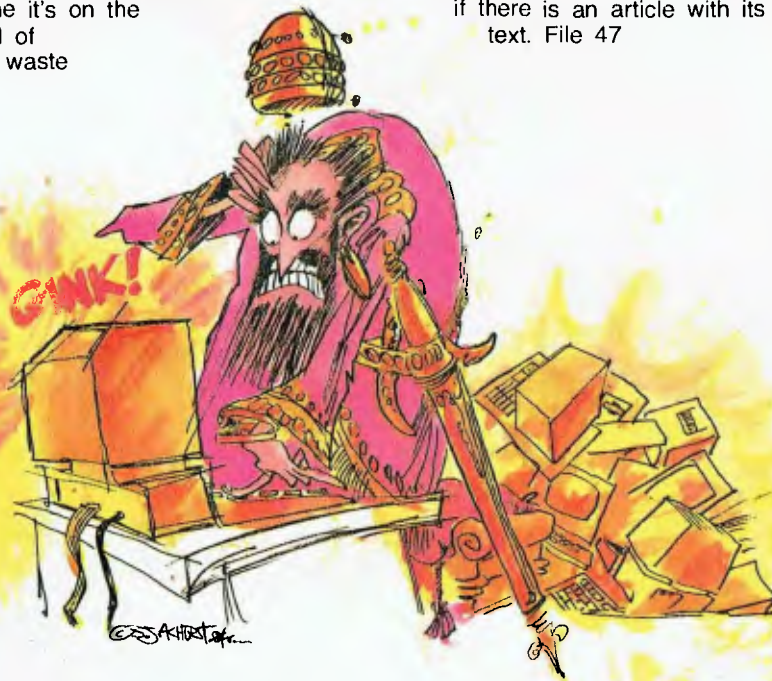

King Midas turns *another* computer to gold as he attempts to log on ...

## Videotex

*The DIALOG database system is concerned exclusively with textual information retrieval. While straight text is the appropriate medium for this form of information utility, there are times when some form of graphic presentation is particularly desirable. The combination of graphics, colour and interaction is at the heart of most successful software packages. It is also the essence of videotex. Frank Lee explains briefly what videotex is (for more detailed information see Norman Kemp's article in 'Your Business Computer' August 1984) and describes how one videotex system, called Cybertel, works.*

VIDEOTEX is a 'generic' term, not a trade name. It describes a group of computer information services which share certain common characteristics. Alternative terms are 'Interactive videotex' (or Viewdata in Europe).

Videotex systems offer interactive information facilities over the public switched telephone network or cable TV lines. But unlike their strictly textual counterparts, the videotex systems present their information in colour graphics. The end user interacts with these graphical messages through a keyboard in order to proceed to more specific information requirements. It is possible to view selected advertising material, airline schedules, tourist information, and so on. It is also possible for the viewer to purchase advertised items, to book a particular flight, or to take a particular tour.

### Videotex in Australia

Australian videotex has had a very slow start. Telecom's proposed Viatel service announced last June has found it difficult to attract information providers. It would appear this may be due to Telecom's charge of \$1000 per month for each new information source. Viatel's domestic users are likely to be expected to pay a flat \$5 per month plus a connection charge of \$6 per

## A picture's worth a thousand words

hour. The user will also be hit by the IPs for their services. Hooking into the system requires either a special terminal, or an adaptor for an existing colour television, or a special card for a personal computer. Adaptors are expected to cost around \$500, while dedicated terminals will cost between \$1000 and \$2000. Special cards are available for the Apple II, the BBC micro, and the Spectrum.

According to Control Data (Australia), the introduction of videotex in Australia will have far reaching consequences for the banking and financial sector. They cite the following advantages:

- Ease of use – for example, in customer self-service banking
- Flexible, efficient banking communication
- Fast updates for new procedures and exchange rates
- Ability to produce low-cost cash management services to corporate and home banking clients
- Low costs and communications charges
- 24-hour service nationally.

### Cybertel

I recently took the opportunity of seeing Control Data Australia's own Cybertel videotex system in action. The demonstration terminal was of the dedicated variety, although the colour monitor was a normal high-resolution display system with conventional interfaces. An auto-dial split-speed



modem (1200 baud in the receive direction, 75 baud in reverse) linked the control unit to the telephone switched network.

The Cybertel system is managed by a pair of PDP 11/44s in Melbourne, running under the RSX11M Operating System. Connection to these machines may be either by telephone (as in the case of this demonstration machine), or via Austpac. In any event, it costs only the equivalent of a local phone call from any point in Australia to make the connection.

I was a little surprised that the engines running the system were not from the CDC Cyber stable.

In common with other videotex services, access to a particular information service is made through the use of tree-structured menus. A handheld keyboard is used for steering and data entry. Larger systems offer more conventional terminal facilities, and resemble a microcomputer system less the disk drives. The demonstration unit sported a small thermal graphics printer which could silently generate a reasonable (but black and white) facsimile of the display screen. Some of the illustrations associated with this article were generated by that printer.

### What Will it Do?

The Cybertel system offers a range of services, but will generally suit the corporate user rather than individuals. The 'mailbox' service is applicable to organisations geared for the exchange of electronic mail. Individuals could be interested in it from a 'bulletin board' aspect, but may get more joy from special interest RBBSS.

One of the IPs is the ANZ Banking Group, which supplies an on-line bulletin giving up to date currency exchange rates. There is also a utility which lets you convert an amount in

any currency to its equivalent in any other currency.

Cybertel's catch cry is "What's the most important thing to every business? To keep up with the competition, or to keep ahead?" The answer is clearly the latter. Hence the need for up-to-the-minute information. Success of the system rests heavily upon the individual IPs and the services which they can provide. IPs include General Motors Holden, Jetset Tours and the Victorian Department of Agriculture. Clearly, the users include Holden dealerships, travel agents and farmers. I also saw information screens for real estate offerings and commodity futures.

Other Cybertel services include world economic indicators, trade fair information, company reports and recommendations for good restaurants. Anticipated future applications include cinema and theatre guides, consumer advice, news headlines, sports results, weather reports and games. My reaction to the idea of games on Cybertel is that you'd be better advised to buy a Vic 20. If I ran a business which used Cybertel extensively, the availability of games (for the use of my staff) would not go down well.

### Cybertel Charges

Three basic charges apply:

1. An annual subscription of \$100.00.
2. One local call fee per connection.
3. A connection fee of 20 cents per minute.

In addition, each of the IPs will charge a fee according to the service provided. Since this is a non-trivial calculation, you would need to consult the IP concerned for details.

As the number of Cybertel IPs grows, so will its user base. One wonders how long two PDP 11/44s will cope with the load. CDA no doubt hopes "not for long".

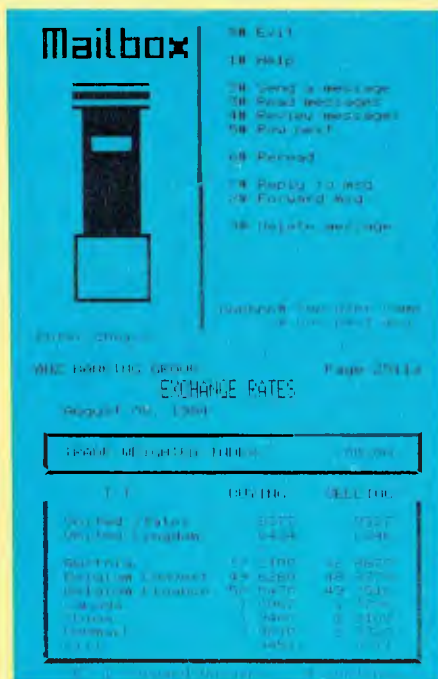

# Telecom – at the heart of data transmission

Telecom Australia is the supplier and maintainer of 'end to end' data transmission services in Australia. With new and up-dated services continually being introduced to meet the developing needs of Australian business.

Planning for data services can be complex indeed, but by contacting a Telecom Data Consultant in the early stages of your planning process, you can be advised of the right service for your particular application.

An installation date that suits you can also be negotiated through early consultation with Telecom.

Any major investment in computer equipment warrants careful consideration of the data transmission service options – Telecom expertise helps you invest with confidence.

## **Telecom – the major force in data communications.**

### **Datel Service**

Switched network and leased line services Australia-wide with on-going enhancements to the wide range of data transmission facilities.

### **Digital Data Service**

A synchronous leased line service for the larger user where long distance data communications are required. DDS also offers network multiplexing facilities not previously available in Australia.

### **Austpac**

The switched data communications network, utilising the latest in packet switching technology and offering distance-independent pricing. Austpac has been specifically designed for emerging computer applications leading to greater opportunities in the business world.

For further information on how Telecom can help you make the best possible use of your computer facilities, in particular at the crucial planning stage, contact one of our data offices: Sydney (02) 267 6767, Melbourne (03) 605 6250, Brisbane (07) 835 6400, Adelaide (08) 225 7435, Perth (09) 420 7200, Hobart (002) 20 8800, Canberra (062) 45 5555.



**Telecom Australia**

The Vital Connection

TAT 278/M

? ?select

? SELECT

\*The SELECT (or S) command is used to retrieve records. Each SELECT command results in a set of records containing the search element(s) SELECTed, for example,

SELECT MICROWAVES

retrieves records with the term MICRO-WAVES, or

SELECT AU=NEWMAN, EDWIN

retrieves records with EDWIN NEWMAN as the author. E or R reference numbers from EXPAN displays may also be SELECTed:

SELECT E6,E6,E11-E14

This command results in a single set which combines entries for all terms with the E reference numbers requested.

\*\*The SELECT may also be used with the Boolean operators: AND, OR, NOT, for example,

SELECT AIR AND POLLUTION

SELECT SOLAR OR SUN

SELECT AU=PAULING? AND VITAMIN?

each SELECT statement shown will result in a single set, but the number of records for each part is displayed.

\*\*\*SELECT STEPS (or SS) may be used with AND, OR, NOT to retrieve a separate set for each part.

**Figure 1. The conversation after asking for help with 'select'.**

? b47

File47:MAGAZINE INDEX - 1959-March 1970, 1973-84/Jul

(Copr. IAC)

**Figure 2. Logging on to the required database.**

is advertised as offering a truly broad coverage of over 400 general interest magazines with the full text of over 50 such magazines. Sounds great. File 47 it is.

The preceding thought processes were carried out *off line*! If carried out on-line, you cop the financial penalty of being connected through MIDAS at \$12 per hour, a smaller additional charge for using the USA-based network, plus the hourly cost of being connected to the specific database (\$US84 per hour for file 47). When logged on, you work *fast*.

Having fired up Harlequin, his Z80A purring on all eight bits, we begin by loading our privately tampered version of MODEM7. Up comes the menu of goodies, from which we select the 'T' option (for Talk). The command in this case is T C:NUKE which tells

MODEM7 to open a file called NUKE on drive C. At the end of the session the trapped conversation will be dumped into that file.

MODEM7 now turns Harlequin into a dumb terminal with a memory. I hit a control-Y to tell the program to capture each keystroke (both ways) in main memory, then dial up OTC on (02) 20991. The phone rings a couple of times, is answered by the mindless engine at OTC which then tells its answering modem to whistle at me. On hearing the whistle, we flick the modem switch from 'phone' to 'modem', thereby connecting the phone line direct to the modem. The phone is now dead, but the modem responds to the incoming whistle by turning on its little green eye (the 'carrier' light).

A moment later, the message

*Please type your terminal identifier* appears slowly on the screen. I hit the letter 'e' to tell MIDAS what sort of terminal I think I am. MIDAS responds with a quick

-2716:02-052-

which no doubt has great significance. This is then followed by the invitation to

*Please log in:*

at which point I enter the (fictitious) identifier SHDF848ABC and hit the RETURN key. MIDAS then asks me for the password to which the (fictitious) reply is SAAA1684. The password is not echoed on the screen. Its acceptance is then indicated by a simple prompt character (;). We now have a choice of using either Telenet or Tymnet to access DIALOG. Tymnet has three ports, each identified by a ten-digit sequence. If one is unavailable, we can select another. Telenet is identified by another ten-digit sequence. We select one, enter it and hit RETURN. The reply comes back

*Remote: call connected  
ENTER YOUR DIALOG  
PASSWORD*

As an authorised DIALOG user, you have your own password to enter here. In our case, the reply (on giving the right password) was

*LOGON File1 Thu 16aug84 16:54:02  
Port05B*

followed by a heap of useful information about files which are not currently available, how to get assistance and important news items, new files now available, free introductory time allowances, and the like.

Finally, DIALOG issues its universal prompt - a question mark.

### Calling for Assistance

Being somewhat rusty, it seemed appropriate to see what would happen if we asked for help on using the SELECT command.

Help on any command can generally be obtained by typing a question mark followed by the command in question. The conversation went as shown in Figure 1.

But first we have to log on to the required database, file 47 in this case (Magazine Index). You can enter the command in full as

*BEGIN 47*

# EXCELLENCE

## THAT'S OUR BOTTOM LINE

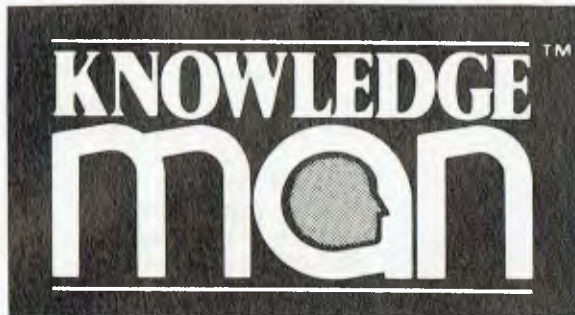

### DECISION SUPPORT

Chances are you won't find a job the Knowledge Manager can't do.  
Environments:

PC DOS/MS DOS/  
CPM 86



### DATA MANAGEMENT

A complete data management tool that goes beyond file management.  
Environment:

PC DOS/MS DOS/  
CPM 86/CPM 80



### MAINFRAME STATISTICS ON YOUR MICRO

Designed to provide a modular working environment which can easily adapt to new machine architecture and user interfaces.  
Environment:

PC DOS/MS DOS/  
CPM 86/CPM 80/  
UNIX



### PROJECT MANAGEMENT

Incorporating the critical path method (CPM) and the program evaluation and review technique (PERT).  
Environment:

PC DOS/MS DOS

TM-KNOWLEDGEMAN-CONDOR-SYSTAT-THE HARVARD PROJECT MANAGER ARE TRADE MARKS OF MDBS INC.-CONDOR COMPUTER INC.-SYSTAT INC.-HARVARD SOFTWARE INC. RESPECTIVELY.

## DATA*B*ASE MANAGEMENT SERVICES

SUITE 6-83 GLEN EIRA ROAD, RIPPONLEA 3183 (03) 523 5947  
TELEX NO. 30625ME 721 DEALER ENQUIRIES WELCOME

\*ITAL1/2/1

1735578 DATABASE: MI File 47 \*Use Format 9 for FULL TEXT\*

Sweden to store nuclear waste under sea.

Young, Dennis A.

Research & Development v26 p55(1) March 1984

AVAILABILITY: FULL TEXT Online

LINE COUNT: 00014

GEOGRAPHIC LOCATION: Sweden

GEOGRAPHIC CODE: EVSW SIC CODE: 4953

DESCRIPTORS: radioactive waste disposal in the ocean-sweden; tunnels-planning; Sweden-industries

1/2/2

1648386 DATABASE: MI File 47

Thermodiffusional transport in pelagic clay: implications for nuclear waste disposal in geological media.

Thornton, E.C.; Seyfried, W.E.

Science v220 p1156(3) June 10 1983

CODEN: SCIEAS

illustration; table; graph

SIC CODE: 7391

CAPTIONS: Experimental values of the Soret coefficients.; (Change in relative fluid composition with time of hot and cool zones of control and sediment thermal gradient experiments.)

DESCRIPTORS: geological research-industrial applications; radioactive waste disposal in the ocean-research; clay soils-geology

Figure 3. Summaries of two of the records accessed.

or simply use the first letter (as b47). You can see the conversation in Figure 2.

We now enter our search strategy using the Search command to locate all magazine articles which feature the word-pair 'nuclear waste', a word starting with 'dispos', and a word starting with 'ocean'. The command used was:

*s nuclear(w)waste and dispos? and ocean?*

DIALOG responded in a few seconds with

110 NUCLEAR(W)WASTE  
1730 DISPOS?  
3767 OCEAN?

1 5 NUCLEAR(W)WASTE AND  
DISPOS? AND OCEAN?

This tells us that it has located 110 records featuring the word pair 'nuclear waste', 1730 with 'dispos' and 3767 with 'ocean'. Finally it tells us that there is a set of five records which feature all these components, and the set number is '1'. Next we

decide to get an overview of these five articles with the command T 1/2/1-5. This asks for a 'type-out' of set 1, using format '2' for records 1 through 5. Format 2 is a brief summary.

The first two summaries are shown in Figure 3.

Noting that record 1 was the only one to be available also in full text form, we used format 9 to get the whole text with the command T 1/9/1. The result was a repeat of the previous summary plus about 17 lines of text - just what Mimi ordered.

Next, we logged off the system with the command (you guessed it) LOGOFF. Just before cutting the MIDAS/DIALOG link, we got a cost report for everything except the MIDAS link.

Incidentally, if you happen to be outside the Sydney telephone exchange area, the call to OTC still only runs to a local call fee.

The 'phone/modem' switch was then set back to 'phone', and the telephone replaced on its cradle. The

whole conversation is still in Harlequin's main memory, so we used a short command sequence to dump the memory to the previously nominated file (C:NUKE). This was then edited (with WordStar), and the project was off to a flying (and not too expensive) start.

## For Hackers and Programmers

DIALOG is also valuable for micro hackers and programmers generally. Some files of interest include the following:

**File 256** 'Business/Professional Software Database' - descriptions of over 3000 software packages which have business applications. It is geared for microcomputer and minicomputer users. There is enough information to complete the selection and purchase of a package.

**File 232** 'MENU - The International Software Database' - includes 15,000 records describing over 55,000 different software packages, with monthly updates. It is possible to order a program through the system.

**File 233** 'Microcomputer Index' - contains nearly 22,000 records with quarterly updates. It provides abstracts of articles published in 50 microcomputer journals. (We didn't check to see if YC was included).

Since you could be spending upwards of \$1.50 per minute when hooked up to DIALOG, it clearly pays to plan your search strategy in advance. If you reach a point during searching where you are not sure of what to do next - log off. This will give you time to think before logging back onto the system.

Now, another word about costs. If connecting to DIALOG through OTC's MIDAS system, you will pay \$12 per connect hour plus 60 cents per thousand characters transmitted (either way). There is no minimum usage fee.

There is a nasty rumour that MIDAS may soon be taken over by Austpac, in which case the charging will be somewhat different - and almost certainly more expensive. At present Austpac requires an initial \$50 registration fee plus a monthly charge of \$3 for your user identification. At the time of writing there was no information available on when (if at all) this transfer will take place. We'll try to keep you informed. □

# Australia's International Electronic Message Service . . .



# Minerva

*We've long been promised a paperless office environment. OTC's electronic mailing system, Minerva, is touted as the service that could finally rid us of filing cabinets, inter-company memos, in/out trays, bound appointment diaries, and so on. Frank Lee logged onto the system and made like a legitimate user (well, almost) – here he comments on his findings.*

ACCORDING TO one encyclopedia, the Roman goddess Minerva was the dispenser of Wisdom, the Arts, Sciences and Handicrafts. Introduced originally by the Etruscans, she was subsequently adopted into the Greek pantheon under the name Athene. The Greeks must have thought she was a bit of all right since they named their capital city after her.

OTC, Australia's Overseas Telecommunications Commission, must also have a soft spot for this female Manager of Good Things, for Minerva is OTC's latest electronic offering.

In a particularly glossy brochure, OTC asks "In a business world without paper, will you write a success story?". Grief! what will be the electronic equivalent of toilet paper? ▶

# BREAKTHROUGH!!

## COMMUNICATE AT 1200bps AT AN AFFORDABLE PRICE WITH THE NEW SHUTTLE MK XII INTELLIGENT MODEM

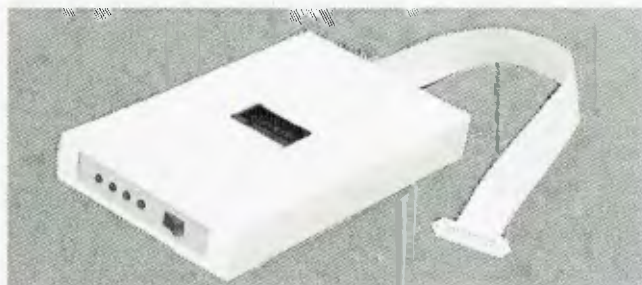

The MARK XII operates at 1200bps full duplex in CCITT V22<sup>T.M.</sup> and Bell 212 modes and utilizes the widely accepted Hayes command structure to operate automatically with most communications software programs on the market. We can supply software to suit most systems also plug-in telephone handsets

- AUTO DIAL
- AUTO ANSWER
- HAYES COMPATIBLE

### \$595.00

INCLUDING SALES TAX.

**ORDER NOW TO ASSURE EARLY DELIVERY  
OR CLIP AND MAIL COUPON TO:**

R. F. Computer Communication Pty Ltd  
2 Rosedale Grove  
Frankston Vic 3199

Please rush SHUTTLE MK XII details to:

NAME .....

ADDRESS .....

TELEPHONE .....



**RF COMPUTER COMMUNICATIONS PTY LTD**  
2 ROSEDALE GROVE  
FRANKSTON 3199  
Tel (03) 787 7063 Telex 13502  
R. F. Comp. Comm.



## SPHERE COMPUTERS

### The CCT 100 Intelligent Terminal for Intelligent decision makers.

#### SPECIFICATIONS

##### Keyboard

- Detachable, compactive, typewriter-style keyboard
- N-key rollover with auto repeat capability
- 4 LED indicators for caps lock, on line, black mode and keyboard lock/protect
- Audible keyclick enable/disable
- Auto repeat enable/disable
- Keyboard lock enable/disable
- Repeat rate 20 characters per second
- 5 cursor control keys, 10 editing function keys with 14-key numeric key-pad

##### Communication

- Code: 128 ASCII characters
- Baud rate: 75, 110, 150, 300, 600, 1200, 1800, 2400, 4800, 9600, 19200
- Parity: add, even, mark, space
- Operating Mode: full duplex, half duplex or black mode
- Interface: EIA RS-232C or 20-mA Current Loop

##### Emulation

- LEAR SIEGLER ADM 3A ADM 5A, HAZELTINE 1500, ADDS VIEWPOINT

##### Screen Presentation

- Display format: 24 lines x 80 characters
- Display unit: 12-inch, non-glare CRT
- Character type: 7 x 9 dot matrix
- Refresh rate: 50/60 Hz
- Character set: 96 ASCII characters, 15 graphic symbols, 32 control character symbols
- 5 screen attributes: blink, underline, blank, reverse, dual intensity
- Cursor type: selectable slow, fast blinking or steady cursor, block, underline or invisible cursor.

##### External Control

- |                          |                              |                                   |
|--------------------------|------------------------------|-----------------------------------|
| ● Power on/off           | ● Refresh rate               | ● EIA or 20-mA Current Loop       |
| ● Contrast adjustment    | ● Half duplex or full duplex | ● Reverse video or standard video |
| ● Baud rate              | ● Auto line feed             | ● End of message                  |
| ● Parity and data format | ● Auto new line              | ● Emulation mode                  |



**ONLY  
\$699.00**

+ Sales Tax if applicable  
F.O.B. Ex-Sydney.



**AVAILABLE FROM OFFICES AND SHOWROOM PARIS RADIO ELECTRONICS,  
SHOP 1, 165 BUNNERONG ROAD, KINGSFORD, NSW 2032. TEL. (02) 344 9111. TELEX AA22579.**

# Minerva

Minerva has been available since late 1983, primarily as a message switching system for businesses. It is accessed in exactly the same way as is DIALOG, via the MIDAS system (see my article 'Let's Dialog' elsewhere in this issue). In other words, you will need a modem, a microcomputer of some sort, and a telephone line. Suitable communications software will enable your computer to control the modem and to capture 'conversations between you and the remote system.

Although advertised primarily as an electronic mailing system, Minerva offers a broad range of additional services. These include:

- Personal and corporate diary
- World news services
- International airline information
- A 'chat' facility
- Forms processing
- Word processing
- Bulletin boards
- Electronic conferencing
- International user directory
- Application programs
- Software tools.

Most of these services are mediated by OTC's own computer system; however, there is direct access to overseas facilities via a satellite link. Clearly it makes little sense to handle a diary system via satellite, but it is essential for up to the minute news

announcements. The electronic mail system functions both in Australia and overseas.

## Invoking the Goddess

Assuming you have the right communications equipment and software, and that you are an authorised Minerva user, here's how one logs on to the system.

The first step is to fire up your micro so that it emulates a simple terminal. If your modem runs at 300 baud, dial OTC on (02) 20991. If your modem handles 1200 baud, dial (02) 20992.

When the auto-answer modem at OTC answers your call, you will hear a high-pitched whistle. At this point, switch your modem from 'phone' to 'modem'. Some systems will do this automatically for you. Your modem now replies to OTC with its own whistle (a carrier tone). On hearing this tone, the OTC computer commences the conversation by transmitting:

*Please type your terminal identifier to which you should reply by pressing the letter 'e' (in lower case). OTC then invites you to 'log in', which you do by typing the word 'minerva' followed by a carriage return. You*

are now connected to the Minerva system, but there are still a couple of hurdles to leap before you can use the system.

Minerva sends:

*Please Sign On*

You then enter your identification number, which was issued to you by OTC when you were authorised. Another prompt from Minerva appears:

*Password:*

When you enter your issued password, Minerva suppresses the echo so it does not appear on the display screen (or in your capture file).

If your identification number and password are accepted, you should see a log-on message something like this:

*Minerva: System 58*

*On At 21:53 10/08/84 AEST*

*Last On At 13:32 10/08/84 AEST*

which is pretty self-explanatory. Indeed, most of Minerva's chit-chat is geared for the novice or infrequent ▶



## TELEX NETWORK

## TELETEXT NETWORK

## DATABASE ACCESS

## ELECTRONIC MAIL

Diary

World News Service

International Airline Guide

Chat

Forms Processing

Word processing Interface

Notice Boards

Conference

On-line Directory

# Join The Revolution!

Return this coupon and keep up with the tide of  
Macintosh & Lisa developments.

The Macintosh and Lisa personal computers represent a revolution in the way we think about computers. So simple, yet so powerful. And about to precipitate the most significant revolution in computer history! Around 75,000 Macintoshes were sold in the first 100 days, such is the impact this computer has had. Lisa was voted 'Computer of the Year' in 1983.

City Personal Computers are Sydney's Macintosh and Lisa specialists. We want you to know all about the exciting developments as they happen and that's why we're offering a free newsletter dealing just with this area. We'll tell you all about the programs, the peripherals and the concepts that are happening so quickly in the US and that will soon be here.

And if you feel your own revolution would go better with a demonstration, call at one of our stores. It's the first step to seizing power!

Hard disk for Macintosh.  
Unix for Lisa.  
Mac Terminal.  
Mac Pascal.



Latest announcements from US.  
Accounting software.  
DATABASES.  
Mac add-ons.  
Covers for Mac & Lisa.  
Microsoft preview.



Just some of the topics to be covered in the newsletters.



SYDNEY  
55 YORK ST.,  
(02) 29-2461

NORTH SYDNEY  
100 MOUNT ST.,  
(02) 922-3600



**CITY  
PERSONAL  
COMPUTERS**



```

***** ITT DIALCOM'S AUTOMATED OFFICE SYSTEMS *****

Menu of General Services

(GENERAL PRODUCTS)
>MAIL .....ELECTRONIC MAIL
>CHAT id ....INTERACTIVE MESSAGING
>NET-TALK ...INTERACTIVE MESSAGING
>REQUEST ....ELECTRONIC FORMS
>POST .....PUBLIC BULLETIN BOARD
>PRPOST ....PRIVATE BULLETIN BOARD
>CAL .....CALENDAR System

(SPECIAL PRODUCTS)
>NEWS.....ELECTRONIC NEWSWIRES
>NEWSTAB ....NEWSWIRE CLIPPING
>UNISTOX ....UPI STOCK REPORTS
>ABI .....ABI/INFORM
>OAG .....OFFICIAL AIRLINE GUIDE
>INFOX .....DATABASE MANAGEMENT

(GENERAL UTILITIES)
>OFF .....Sign OFF the System
>NETWORK .....List NETWORK Phone#s
>PASSWD .....Change your PASSWORD
>TERM .....Set TERMINAL Type
>ONLINE .....Who is Online?
>INFO .....Get info on commands

>ED .....EDITOR-Create file
>ED filename ..EDITOR-Edit a file
>SPELL .....DICTIONARY EDITOR
>TY filename ..Type/Display Textfile
>DEL filename ..Delete file
>RUNOF .....TEXT FORMATTING

```

Figure 1. Minerva's 'help' screen.

user. The '58' in the first line is Minerva's system number in the international DIALCOM electronic message network. Through DIALCOM, Minerva may communicate directly with the United States, Canada, the United Kingdom, Hong Kong and Singapore. The 'AEST' stands for Australian Eastern Standard Time (not American), and the dates are in the familiar Aussie format DD/MM/YY.

Following the log-on message, you may see a note advising that you have mail waiting to be read. There may also be a 'message of the day' announcing some new facility, or changes to schedules, or whatever. Finally, you should see the standard system prompt ">" (beloved of both CP/M and MS DOS users).

### Minerva Commands

Now you may enter a command, or run one of the special programs. There is also a command which is almost universal for English-speaking systems. If you enter the word "help", you get the message shown in Figure 1.

One problem with 'soft copy' systems (where the text scrolls off the screen into the never-never) is that helpful goodies like the above disappear as soon as you do something else. A mistake which I made was to ignore the OFF command. If you try to terminate the session with END, or LOGOFF, the reply is a bit of a put-down:

#### Illegal Command

The help file is fairly self explanatory. The commands headed 'General

Products' are probably the most commonly used set, MAIL being the electronic mailing system. MAIL makes sense only in a corporate environment (otherwise to whom shall we mail?).

Another important pseudo-command is QUIT. You can enter this at almost any point while using the system in order to return to the main system prompt.

### Electronic Mail

The MAIL command can be issued with a variety of qualifiers. For example, if we give the command MAIL DIS DIR, Minerva displays the corporate distribution directory, one line per user giving the user's name, identification number and position within the organisation.

I tried this while logged on as a (temporary and gratuitous) OTC user. Accordingly, the list generated was quite substantial. Not wishing to waste valuable system time, I pressed the BREAK key on my VDU in order to interrupt the listing. Unfortunately, nothing happened. The listing carried on and on and on. It seemed that the BREAK key on my machine had been disabled, or possibly the software was incapable of planting a BREAK on the serial output. Since many other micro users may be in the same boat, let me pass on the following simple tip: if your modem has a switch to select between 'answer' and 'originate' frequencies, (such as the Dick Smith Dataphone), flick it briefly to the 'answer' position, then back to 'originate'. Minerva will

interpret the break in transmission as a request to interrupt the current task. It may also work if you flick the 'phone/modem' switch, although I haven't tried it.

If you supply the unadorned command MAIL, Minerva responds with

#### Send, Read or Scan

If SCAN is selected, you are given a summary of your pending mail items. Each will show the author, the author's ID number, when posted, and the subject matter. One may also qualify the SCAN command to scan only unread mail, items flagged 'express', items from a specific sender, mail with a certain keyword in the subject matter heading, or with a selected word in the body of the text.

The READ command may also be qualified in much the same way as the SCAN command. You may also FILE your mail, FORWARD it to another user, REPLY to the sender, or DELETE the item. Mail items which have been FILED may be retrieved by category; for example, the command READ FILE MEETINGS FR J. SMITH reads all mail FILED in category MEETINGS from J. SMITH. This illustrates the non-jargon structure of the Minerva command language generally.

Although mail can be sent to a specific addressee, you can also send a letter to a defined group. Courtesy copies can be specified. Other SEND qualifiers allow you to nominate 'blind copies' (a courtesy copy sent without the addressee knowing), automatic acknowledgement when the item is read, forcing the reader to send an immediate reply by prompting, and flagging the item for express delivery (that is, it goes to the top of the receiver's list).

Naturally, mail can also be transmitted beyond the confines of the organisation. In particular, the DIALCOM link allows mail to be sent to international destinations.

Minerva's word processor allows a letter to be composed, then checked for spelling errors prior to transmission. The EDIT mode may be entered at any time while typing a letter. Simple alphabetic commands support moving around the text, and making changes.

All in all, Minerva's mail is similar to the UNIX mail system, but is much more sophisticated.

### Electronic Executive Diary

The DIARY subsystem is designed to be an easy to use appointment scheduling utility. There are four basic

NOW there is a REASON to buy a computer. Introducing . . .

# Meta-4

## the Australian data base adventure

### A WINNER

WINNER of 1st PRIZE in the Business Division of the 1983 AUSOM\* Challenge programming competition sponsored by VERBATIM (Australia) Pty. Ltd.

\*Apple Users Society of Melbourne

META4 is a revolutionary new data base system which gives YOU full control of your computer with NO PROGRAMMING. No other data base system even comes near it. Now you can have an integrated Data Base system for your business for only \$395.00. META4 may be the only program you need to buy for your computer.

#### BASIC FACILITIES

META4 is a comprehensive Data Base Management system, including:

- FULL DATA BASE
- SIMPLE SPREAD-SHEET
- SIMPLE WORD-PROCESSING
- MAILING LISTS
- STANDARD LETTERS
- LABELS

#### THINK OF AN APPLICATION

META4 is suitable for a very wide variety of business, professional, academic and personal applications, such as

- |                     |                |
|---------------------|----------------|
| <b>BUSINESS</b>     |                |
| CUSTOMERS           | QUOTES         |
| ORDERS              | SALES          |
| INVOICES            | ACCOUNTS       |
| CREDITORS           | NAMES          |
| LETTERS             | ADDRESSES      |
| FINANCIAL           | LABELS         |
| SUPPLIERS           | PRODUCTS       |
| CATALOGUES          | PERSONNEL      |
| ORG STRUCTURE       | DEPTS          |
| <b>PROFESSIONAL</b> |                |
| MEDICAL             | DENTAL         |
| LEGAL               | PHARMACEUTICAL |
| INSURANCE           | FARMING        |
| <b>ACADEMIC</b>     |                |
| LIBRARY             | STUDENTS       |
| TIMETABLES          | SCORES         |
| BOOKS               | BORROWERS      |
| PAPERS              | AUTHORS        |
| REFERENCES          | LECTURES       |
| FORMULAE            |                |
| <b>INDUSTRY</b>     |                |
| VEHICLES            | REPAIRS        |
| MAINTENANCE         | PRODUCTION     |
| <b>REAL ESTATE</b>  |                |
| PROPERTIES          | ENQUIRIES      |
| ADVERTISING         | CLIENTS        |
| RENT                | COMMISSIONS    |
| <b>PROJECT</b>      |                |
| TASK LISTS          | SCHEDULES      |
| DIARY               | MEETINGS       |
| MANUALS             | DOCUMENT'N     |
| TIMESHEETS          | ESTIMATING     |
| BUOGETS             |                |

Information from any or all of the above applications can be AUTOMATICALLY LINKED & CROSS-REFERENCED, since META4 is a true Data Base system.

### 1. MONEY-BACK GUARANTEE

If you are not satisfied with META4, return it within 14 days for a cheerful refund. If you buy from a dealer, check he is prepared to do this before you buy.

### 2. TELEPHONE CONSULTING

If there is something you want clarified after you have purchased META4, ring us up. Maximum time for any one call 15 minutes.

#### BASIC CONCEPTS

META4 uses familiar concepts to aid you in it's use.

**ROOMS** — META4 has many rooms in it. Each room is used to store information about a different type of thing.

**QUESTIONS & ANSWERS** — when you go into a ROOM META4 asks you QUESTIONS about the type of thing (e.g. CUSTOMER INVOICE, PRODUCT etc) held in the ROOM and stores away your ANSWERS.

**RECORDS** — META4 stores the ANSWERS to a set of QUESTIONS in a room as a RECORD. There can be many RECORDS in a room.

**DOORWAYS** — You can move from ROOM to ROOM through DOORWAYS. META4 automatically relates information in one ROOM to information in the rest.

**BUILDINGS** — A building is a collection of related ROOMS and DOORWAYS. A BUILDING corresponds to the traditional concept of a Data Base.

#### META4 IS PORTABLE

Any application you develop under META4 will run without change on any computer that META4 runs on.

#### EASE OF USE

- SIMPLE AND CONSISTENT
- HELP — 3 levels for the current
- BUILDING you are in
- ROOM you are in
- QUESTION being asked
- 3 TUTORIALS
- USING META4
- DESIGNING WITH META4
- META4 EXAMPLES

Designed from the ground up to be totally consistent and as easy to install, learn and use as possible.

#### META 4 IS EXTENDABLE

All the features of the system are fully extendable to your own applications. You can add your own BUILDINGS, ROOMS, DOORWAYS, and QUESTIONS. You can define your own maps, HELP text and tutorials.

#### SELLING YOUR META4 APPLICATIONS

If you wish to sell your application you will have the widest possible market. We will evaluate your application and may assist in marketing it.

#### DETAILED FACILITIES

- Menu drives
- True DATA BASE — RELATIONAL/NETWORK
- Variety of Answer-typas e.g. CALCULATED, DATE, YES/NO, NUMERIC, TEXT, LIST
- FULL PROMPTING
- Automatic VALIDATION
- Powerful Selection & Reporting
- All facilities fully EXTENDABLE to user's own applications
- No programming
- Full DATA DICTIONARY defined as a META4 application
- Automatic TOTALLING of lists
- Automatic COPYING of ANSWERS from one room to another
- Automatic MAINTENANCE of records in other rooms (Secondary Index facility)
- Copying of information to and from other products such as WORDSTAR
- B-Tree ISAM Source Code

#### DISK FORMATS AVAILABLE

- 5" IBM-PC DOS 320K
  - 5" APPLE-II CP/M 126K
  - 8" CP/M SS/SD 256K
- Other formats by request

#### MINIMUM HARDWARE REQ.

- CP/M — Minimum 56K System
- IBM PC-DOS, MS-DOS — Minimum of 128K RAM
- APPLE-II — 64K RAM, 80-Column Card.
- CP/M card. 2 diskette drives

#### Prices (inc. Sales Tax) \$

- Manual alone . . . . . \$30.00
- META4 (CP/M) . . . . . \$395.00
- META4 (IBM-PC) . . . . . \$395.00
- META4 (MS-DOS) . . . . . \$395.00
- Non-Standard Disk Conversion. . . . . \$50.00
- Post & Packaging . . . . . \$10.00



BACK A WINNER! GO FOR META4. ORDER DIRECT FROM: **SYSTEM SOLUTIONS PTY. LTD., 28-30 PALMERSTON ST, BERWICK VIC (03) 707 2851** OR FROM ANY OF THE FOLLOWING DEALERS:

- VIC: ALPHA R & O (AUSTRALIA) 789 4658. COMPSOFT MICROCOMPUTER SERVICES (03) 428 5269. COMPUTERS 2000 (03) 781 4244. EMERALD HILL COMPUTER BROKERS (03) 690 8095. METROPOLITAN BUSINESS MACHINES (03) 383 2222. PRESIDENT COMPUTERS (03) 529 1788. ROBCOM (AUSTRALASIA) (03) 429 6233
- NSW: J.T. MICROCOMPUTERS (02) 848 0452. THE COMPUTER WORKS (065) 53 5485
- QLD: MERMAID COMPUTERS (075) 35 5511
- WA: COMPUTER AGE (09) 384 1111
- SA: COMPUTER MARKETING HQ (08) 260 2444. GENERAL BUSINESS MACHINES (08) 42 0031

# DATA COMMUNICATIONS

When the POST command is given, Minerva asks for a category. You may select anything from Activities to Testing. I picked Apartments. Figure 5 shows one of the items posted.

From the category 'computers-micro' those in Figure 6 emerged.

## Overseas Airline Guide

Finally, the Overseas Airline Guide was irresistible.

The OAG command generated so much material that we can't include it here. It is a service supplied by Official Airline Guides, Inc. of Oak Brook, Illinois. Using this system, a subscriber can get detailed information about flight schedules, fares and connections. The system has a built-in trainer for newcomers who are not familiar with computers. Using OAG it was possible to list direct flights and indirect connections to get from Sydney to Los Angeles for a given date, and close to a selected departure time. The information was complete, except for a present inability to supply fares apart from continental United States flights. It is not possible to book a seat through OAG; however, prospective travellers could find this utility most valuable in planning a trip without the hassles of going through an agent. Of course it would be necessary to make the final booking with a registered travel agent, or the airline direct.

## Costs

The cost of a Minerva session is based mainly on connect time and storage requirements. A basic \$15 per connect hour is augmented by an additional \$5 per hour if the application

```
>diary
17.08.84          DIALCOM CALENDAR SYSTEM          Ver. 2.06
                  Appointment Book for OTC(AUSTRALIA)

Enter   - to enter appointments
Read #  - to display an item
Scan    - to query by name, date, or character string
Change # - to change an item
Output  - to display schedules
Purge   - to flag old items for removal

PA      - to change your calendar parameters
        or allow others access to your schedule

Enter, Change, Scan or Output:
```

Figure 2. The diary menu.

DIARY commands: OUTPUT, SCAN, ENTER and CHANGE. When the DIARY command is given, you will see the diary menu as in Figure 2.

Note how the diary is maintained for the organisation, not the individual. The system helps you at each stage of an entry or enquiry. An experienced user can employ quite powerful compound commands; for example, if OUTPUT has been requested, giving the following response to the NAME? prompt:

```
J. Smith D 4/1/84 CO YES NO
HERE
```

will display a daily consolidated schedule for the user J. Smith.

To exit from the DIARY subsystem, enter the QUIT command.

## Available Programs

Although not listed in the help file, there are over 200 application programs within the system. These are arranged in the following categories:

- Business
- Commands
- Engineering
- Games
- Language/vocabulary
- Mathematics
- Science
- Statistics
- Cross assemblers

To get a complete listing of all of these offerings, enter the command INFO INFO. The programs will be listed by name, category and short description. Figure 3 shows just a few.

Resisting the temptation to indulge the small child within me with a round of \*TREK, I adopted a more

scholastic expression and entered the command

```
>r french
```

to see what would happen. Figure 4 shows the ensuing (and embarrassing) dialogue. (Minerva's responses are in capitals).

So much for French. I also tried one (not listed) which generated a plot of damped sine wave, just to see how it would handle graphics. As expected, it did its thing using conventional ASCII symbols to mark points on the graph.

## The Bulletin Board

The next foray was into the public bulletin board POST. Surprisingly, this one is based in the United States.

Name	Type	Description
ANNUIT	Busn	Analysis of payment or withdraw annuities *
BALSHT	Busn	Calculates a simple PROFORMA income statement
CSHFLO	Busn	Computes the present values of up to four cash flows
LDEBTS	Busn	Computes monthly payments on simple anuity debts
SALES	Busn	Generates a sales commission report
YRMORT	Busn	Generates a loan amortization schedule table
CHAT	Cmnd	Inter-user conversation
DOC	Cmnd	Program debugger
SPELL	Cmnd	Spelling error detection and correction
XFTN	Cmnd	Extended fortran
BEAM0	Engn	Computes the moment of inertia for beams
FLOOD	Engn	Predicts speed of river flood crest passage
GAMES	Game	Info file listing of all games
*TREK	Game	Expanded version of the Star-Trek game
ADVENTURE	Game	Adventure (Unique and addicting)
LIFE	Game	Life (Colony Generation)
LUNAR	Game	Lunar landing simulation
WUMBUS	Game	Hunt the wumpus
FRENCH	Lang/Voc	French vocabulary drill
LATVERB	Lang/Voc	Latin verb exercise
SPELLING	Lang/Voc	Random word spelling quiz
#123	Math	Counting drill for children
ALLROOTS	Math	Computes rational powers of complex numbers
LPOLYH	Math	Computes coordinates of a regular polyhedra
MATHFACT	Math	Elementary arithmetic drill
POLUT	Sci	Simulates the effects of pollutants on a body of water
LINREGR	Stat	Computes linear regression
LMREG	Stat	Fits a least squares regression line
POLFIT	Stat	A least squares curve fitting program
REGRES	Stat	Performs step-wise regression analysis
184	Xasm	8080/8085 Micro-Processor cross assembler
M68	Xasm	M6800 Micro-Processor cross assembler
Z80	Xasm	Z80 Micro-Processor cross assembler

Figure 3. A few of the programs available in the system.

TYPE THE FRENCH WORD, PHRASE, OR SENTENCE FOR THE WORD, PHRASE, OR SENTENCE GIVEN IN ENGLISH.

USE THE SYMBOL ' FOR YOUR AIGU ACCENT: CAFE'  
 USE THE SYMBOL ' FOR YOUR GRAVE ACCENT: PE'RE  
 USE THE SYMBOL \* FOR YOUR CIRCONFLEXE ACCENT: CHA\*TEAU  
 DISREGARD THE 'CEDILLE', USE PLAIN LETTER C INSTEAD: GARCON

TO STOP THE PROGRAM TYPE 'CELA SUFFIT' OR DEPRESS THE 'BREAK' KEY

MY EYES ARE NOT SO GOOD ANY MORE, SO PLEASE TELL ME:  
 ARE YOU A BOY OR A GIRL? un garcon  
 PLEASE DON'T TRIFLE WITH AN OLD MAN! NOW TELL ME,  
 ARE YOU A BOY OR A GIRL? boy

PLEASE TELL ME YOUR NAME, MONSIEUR? frankie

TYPE THE NUMBER OF YOUR CHOICE OF DRILL MATERIAL:

1. FRENCH VOCABULARY
2. FRENCH VERBS
3. FRENCH EXPRESSIONS SIMILAR IN PRONUNCIATION

? 1

WE SPEAK? nous parlons  
 OUI

MOVIES? cinema  
 NON, AUTRE FOIS ? je ne sais pas  
 LA RE'PONSE EST CINE'MA

MOVIES? cine'ma  
 OUI

AMERICANS? les americains  
 NON, AUTRE FOIS ? non  
 LA RE'PONSE EST AME'RICAINS

AMERICANS? ame'ricains  
 OUI

SLOWLY? lentement  
 OUI

THEY SPEAK(FEM.)? elles parlez  
 NON, AUTRE FOIS ? phooey  
 LA RE'PONSE EST ELLES PARLENT

THEY SPEAK(FEM.)? elles parlent  
 OUI

WELL? bien  
 OUI

MRS? madame  
 OUI

YES? oui  
 OUI

YOU ARE WELCOME? cela suffit

YOU HAVE MADE 3 ERRORS OUT OF THE LAST 7 WORDS.

AU REVOIR, MONSIEUR FRANKIE.

>ah nuts  
 ILLEGAL COMMAND.

Figure 4. Frank's dialogue with Minerva after calling up the 'French' program.

involves opening an international telecommunications link (such as the OAG and POST commands). Further, you are billed for international data transmission at the rate of \$0.60 per thousand characters transmitted. On-line storage charges start at \$0.40 per month per 2K for less than five megabytes, dropping to \$0.10 per month per 2K for over 20 megabytes.

### What's it all Mean, Frankie?

Well, to be frank (what else?), the system probably has little to offer the lone micro-person, since the games on his own micro will far surpass those whose outputs are limited to simple text at 300 bits per second. The bulletin board has little impact to Aussie users. The OAG is neat, but if you've bought yourself a micro,

how are you going to afford to fly to the United States anyway?

Clearly, Minerva is specifically aimed at corporate users. In that environment, it makes a lot of sense. I personally can't see Minerva being the saviour of vast forests, otherwise destined for the paper mill. I estimate that my accumulated correspondence over the last three years could run to 10M, which would cost me around \$1800 each year to maintain on Minerva. My filing cabinet cost \$45.

The electronic mail facility is clearly a good thing, but an organisation considering this as the main justification for Minerva would need to cost the equivalent service of a local area network with electronic mailing software. If the organisation involves overseas offices, then Minerva should have a clear lead.

The corporate diary system would be a valuable tool for getting executives together for meetings, although most secretaries would be able to cope with a purely manual system of scheduling. I have never been impressed with 'diary' and 'scheduler' systems as currently supported, either on mainframes or micros. My problem is that I have this fixation about my own private (physical) diary, which is always where I expect it to be, which consumes no power, and which has just the random access method I am used to.

But heck, Minerva sure is fun.

Subject: room needed  
 From: RJP Posted: Thu 9-Aug-84 19:53 Sys 98  
 Room or basement needed for one or two months while waiting for place to get ready. please send mail to 98:Maureend. This is for the month of august through september. It will be occupied by one 30 yr. old male. Thanks so much!

Figure 5. One of the items in the 'Apartments' file of the POST bulletin board.

Subject: PC-WRITE  
 From: OCL140 Posted: Thu 2-Aug-84 19:13 Sys 64  
 DOES ANYONE USE PC-WRITE VERSION 2.2? WE'RE HAVING A LITTLE TROUBLE WITH THE PRINTER FONTS.

Subject: Macintosh  
 From: YKE013 Posted: Sat 7-July-84 14:02 Sys 52

I am interested in discussing any issues related to the Apple Macintosh. Some topics for discussion are:

- Software and hardware products
- Telecommunications
- Emulation of the IBM 327x terminal family.

Figure 6. An item from POST's 'computers — micro' file.

# The beginnings . . .

# RCPM

I WAS ASKED to write an article on how RCPM systems got started, both here and in the US. Well, it's mostly a story of people, and as far as the Australian end goes there is a lot of that story which hasn't been told before – for reasons which may become obvious as you read on.

The whole Public Access Message System (PAMS) movement, worldwide, has happened since I first became involved with microcomputers. I was there and I lived it. What follows is written largely from memory and I suppose once it's written down and published it will pass into Australian microcomputer folk lore. I've made it as accurate as I can and offer my apologies to anyone I left out.

## Chicago Starts it All

In the beginning there was the Chicago CBBS system.

As far as anyone can tell, Chicago is the cradle of microcomputer Public Access Message Systems. The Chicago 'Community Bulletin Board System' was started by Randy Suess and Ward Christensen as an experiment in microcomputer communications. Randy and Ward wrote the CBBS software and put on line a motley collection of S-100 'left over' hardware running CP/M 1.4. The system used two North Star single-density (just over 100K capacity) disks, so the CBBS software was designed to be as frugal with disk space as possible. I tried to get a definite date for the Chicago CBBS going on line, but there are several dates in the surviving written accounts of the early

days of PAMS systems; Randy Suess has moved and I don't have his current address; and Ward Christensen doesn't really want to talk to anyone about it any more. So the best guess seems to be sometime during 1978.

## Nu Joisy Developments

It didn't take long before a couple of other systems turned up in the greater Chicago area, also running CBBS software. Meanwhile, in New Jersey another type of remote CP/M system, a 'Remote Bulletin Board System' or RBBS was developed. The CBBS software was written in 8080 assembler and you really need to be an 8080 assembler whizz to get a CBBS system running. The RBBS software was mostly written in BASIC (originally TDL BASIC and later MBASIC), which made it much easier for someone lacking a deep understanding of assembler to get a remote access system going. The RBBS software was based on the CBBS systems, but with expanded capabilities.

## XMODEM

With the advent of the easier-to-install RBBS software, remote access CP/M systems began springing up across the USA. The next development was to add file transfer capability to the RBBS systems. Ward Christensen had developed his communications protocol for a program called MODEM which was used widely by members of the Chicago Area Computer Hobbyists Exchange (CACHE) for manually transferring files. The

CACHE group contributed many of the early CP/M User Group programs, so the MODEM program was widely distributed through CP/MUG.

To add file transfer capabilities to an RBBS system required a reliable, secure method of transferring binary object files; so the MODEM program was quickly adapted to become XMODEM, a version of MODEM suitable for remote use. On the whole, the CBBS and RBBS systems did not let a user get anywhere near CP/M – the message system was all the user saw. Once file transfer capabilities were added it was necessary to let the remote user get down to CP/M command level (still with some restriction on what they could do), so the file transfer systems became known as 'Remote CP/M' systems or RCPM.

## PAMS Systems Spread in the US

The idea of microcomputer Public Access Message Systems quickly spread outside the CP/M community and software for other types of computers started to appear. The 'People's Message System' (PMS – not to be confused with PAMS) software was written for the Apple II, and Forum 80 software appeared for the Tandy TRS-80. These were followed by other types of PAMS software for an even wider variety of computers.

Direct-connect modems were readily available, legal and cheap, so US microcomputer users were quick to use the systems as they appeared. It

*Enthusiasm has been the prime mover in getting public access messaging systems set up all around the world. The United States was the leader in the field, and after catching the bug in 1980 Bill Bolton started hacking enthusiastically at the Telecom red tape, to get permission to implement at least a Bulletin Board System in Australia. Several 'Third Parties' later he and some friends succeeded. Here he chronicles the RCPM story.*



was fairly easy for almost anyone to become a System Operator or sysop, as there were no legal impediments.

### **PAMS in Australia**

I first became interested in the idea of setting up some sort of PAMS system in Australia back in 1980. Since I worked in the television industry at that time I was well aware of the multiplicity of Telecom Australia regulations which covered what you could connect to the Telecom network and what you could do with it. So I started to sound out Telecom about the legalities of setting up a PAMS system.

Telecom Australia regulations have a specific clause about 'General Third Party Message Switching Services' (GTPMSS), which seems to be designed to protect Australia Post from competition, and I believe is simply a hangover from when Telecom and Australia Post were both in the one 'Post Master General' department. Telecom took the attitude that a PAMS system was most definitely a GTPMSS, and so was quite out of the question. The GTPMSS regulation was a real stumbling block and it took nearly two years of discussions with Telecom at a variety of levels before a way around the impasse was found.

In the meantime I had visited the US for the first time and had a chance to try a variety of CBBS, RBBS and RCPM systems in San Francisco, Los Angeles and Chicago. I was lucky enough to meet some of

the sysops, including Ward Christensen, Dave Hardy and Kelly Smith, and get a real feel for what running a system involved.

### **Mi-Computer Club**

Not long after I returned from the US, *Your Computer* magazine was started by Matt Whelan. Matt got Les Bell to edit the magazine and Les got me to do a CP/M column for it. I was telling Matt and Les how fantastic the whole PAMS scene was in the US and that got them fired up about it, too. To cut a long story short, Les Bell got so keen on the idea of a PAMS system for *Your Computer* readers that the concept of the Mi-Computer Club was born, together with a PAMS system to service it.

Les took up the running of the battle with Telecom and finally got officials to agree that as the Mi-Computer Club was truly a club with a membership qualification requirement, it wasn't a 'general' third party message switching system, and was therefore allowable. So, on the basis that Mi-Computer Club membership was a prerequisite to accessing the BBS system, Telecom granted approval for it. The Mi-Computer Club BBS system went on line in early 1982, and so qualifies as the first legal BBS system; however, it was running as one timeshare task on a minicomputer and wasn't freely available to just anyone, so it wasn't a microcomputer PAMS.

### **Stirrings in the West**

While all the manoeuvrings with

Telecom were going on, a real PAMS had appeared in Western Australia. Trevor Marshall had been working in the US for some time before returning to Western Australia and setting up an RCPM system using software he'd got from Kelly Smith, one of the major US West Coast SYSOPs.

The system Trevor set up was highly illegal and led a transitory existence. It was a manual answer system, which meant you had to ask Trevor to switch you onto the computer, and its existence was never widely known.

### **The Action Moves East**

After the success with getting the Mi-Computer Club BBS approved, I renewed my efforts with Telecom to get approval for a real PAMS system. As part of the initial thoughts on what the Mi-Computer Club System should be, Les had obtained a recent and complete set of RBBS software and a copy of a program called YAM from Chuck Forsburg in the US.

Les gave me a copy of the software to look at, and I immediately started on a major clean-up and adaptation to Australian conditions. Meanwhile, Trevor Marshall had moved to Sydney. One day, as I was walking into Dick Smith's York Street store, I saw a notice on the wall about Trevor's RCPM system, which was now running at Willoughby in Sydney for two hours a night. That night I was visiting Trevor to find out what he had going. It turned out to be fairly much the same sort of system he'd been running in Perth.



# “Small businesses don't become big businesses by turning down opportunities like this.”

Arguably the most cost effective small business computer available, the Sigma/OKI is already the second biggest selling microcomputer in Japan.

With advanced business applications both in word and data processing, Sigma/OKI offers as standard a host of features which are normally only available at extra cost.

Features such as ◇ In-built printer. ◇ Dual disk drives (up to 2MB storage). ◇ RS232-C interface. ◇ Light pen interface and calendar clock. ◇ High resolution colour monitor. ◇ 30 programmable function keys. ◇ 3 I/O slots.

Plus over \$1,500 worth of CP/M, BASIC, Wordstar, Mailmerge, Calcstar and Spellstar software free.

And the Sigma/OKI range starts from just \$3,300\*.

For more information and the name of your nearest dealer, please contact Tony Barkhazen on (02) 439 6211.

\*excluding sales tax

**SIGMA/OKI**

A division of Sigma Data Corporation,  
1 Waltham Street, Artarmon.

Stewart Roache Watson SIDC 042

Having someone local who I could talk to about RCPM systems gave me a tremendous boost and I established a timetable to get my Software Tools RCPM system going, Telecom approval or not.

Trevor managed to get hold of a 'green card' enabling him to work in the US, and left to take up permanent residence there. So his RCPM system was on line in Sydney for barely two months before it disappeared, having logged approximately 100 calls. It eventually re-emerged as the 'Thousand Oaks Technical RCPM' in Los Angeles, one of the most popular West Coast systems in the US. With Trevor safely where Telecom can't get at him, I can tell of his pivotal role in getting RCPM systems started in Australia.

### Software Tools RCPM

After some more correspondence with Telecom I finally got approval for the Software Tools RCPM system, on the basis that it would only serve CP/M users who were an identifiable community group and could be tested for CP/M knowledge by answering a simple question about CP/M. This overcame the problem of generality and made the system legal.

By this time I was fairly confident that the RBBS/RCPM software I had was stable enough for on-line use. It had been given some preliminary testing on a PABX and seemed to be OK. I had to go into hospital for a minor operation, so the Software Tools RCPM went on line around midday on May 14th, 1982, about an hour before I was admitted to hospital.

It turned out there were still some bugs in the software and the system would 'hang' if there was an overrun error from the communications interface. So while I was in hospital my wife, Sue, was resetting the RCPM system once or twice a day to enable a few more calls to get through before the system would 'hang' again.

The operation was on my leg and I was pretty much unable to move very far at all for a couple of weeks after getting out of hospital. I spent most of that two weeks with my leg up, just watching the RCPM system being used and correcting problems in the software as I saw them occur. At the end of that time, there had been some very significant changes and improvements in the software and the system was truly stable. It probably would have taken months to achieve the same level of stability by any other means.

### Since Then

The subsequent history of PAMS system developments has been well documented in the CP/M Column of *Your Computer*. The MICOM Club in Melbourne was next on line with its CBBS system (though rumour has it they had been 'testing' the system on and off for many months before it was officially on line). The MiCC system was transferred from the mini to a micro and now runs as an RCPM system. Various departments of Telecom Australia itself now support two RCPM systems which are available for public use after hours.

Dick Smith Electronics introduced a cheap, legal direct-connect modem, which was soon followed by others. With ready legal access to free or low-cost PAMS systems, and reliable direct-connect modems, thousands of Australian microcomputer users are now using PAMS systems regularly.

A list of current Australian PAMS systems appears at the end of the 'CP/M column' in each issue of *Your Computer*, and similar lists now also appear in some of the other local magazines (though Steve Withers of *Australian Personal Computer* magazine can't seem to bring himself to list me as the SYSOP of the Software Tools RCPM, maybe because I write for *Your Computer*? ... see, I'm not afraid to give him or APC a plug!).

Many of the systems carry a file on line called AUSTPAMS.DOC (or something similar) which lists all the Australian PAMS systems. AUSTPAMS.DOC is regularly updated and is usually the first place where numbers of new systems appear. There is at least one system in each Australian mainland state.

### The Future

Until relatively recently all the PAMS systems were on CP/M computers. This year has seen the emergence of three different types of TRS-80-based systems, all using locally developed software, as well as IBM-PC-based systems using US software adapted to Australian conditions. It still surprises me that there are no Apple II systems running in Australia, given the number of Apple II systems in the US.

Many new systems have come on line in 1984, and I know there are several more in the planning stage. It's not hard to become a SYSOP and Telecom approval is easy to get, so why not start your own PAMS system?

# THE ONE YOU'VE BEEN WAITING FOR!

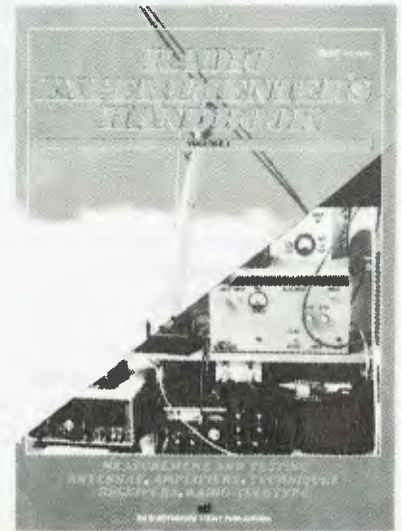

**The Radio Experimenter's Handbook, Volume 1**, from Electronics Today International is 132 pages chock-full of circuits, projects to build, antennas to erect, hints and tips. It covers the field from DX listening to building radioteletype gear, from 'twilight zone' DX to VHF power amplifiers, from building a radio FAX picture decoder to designing loaded and trap dipoles.

Edited by Roger Harrison, VK2ZTB, this book carries a wealth of practical, down-to-earth information useful to anyone interested in the art and science of radio. \$7.95 from your newsagent or through selected electronics suppliers. It is also available mail order through **ETI Book Sales, P.O. Box 227, Waterloo NSW 2017** (please add \$1.75 post and handling when ordering by mail).

## Using Your Computer's . . .

# Bulletin Board

WHEN THE *Your Computer* Bulletin Board started, documentation was issued to new members, but this has since become largely out of date. While what follows does not cover all the information previously issued, it does supplement it and will give you a basic idea of how the system functions.

The Bulletin Board has been a considerable success since it began in November 1982. It logs around 200 calls per week and is frequently accessed by such exotic overseas locations as the US, the UK and Scandinavia. It functions, as its name suggests, like a public notice board where users can leave messages, requests for help and advertisements. It has the added function of being a place where you can leave private messages to other board members, who are able to reply to you using the board.

The System Operator, or sysop, for the system is myself, Evan McHugh. I am responsible for the Bulletin Board when I am not working for *Your Computer* magazine as one of the two assistant editors. I have been involved in computing in one form or another for about five years. Before joining the *Your Computer* team I was with the computing section of a government department in Canberra.

Before I took over the Bulletin Board it was run by Matt Whelan, *Your Computer's* founder, former managing editor and self-taught guru. Matt retains an interest in the board, along the lines of kind assistance through to surrogate-mother 'advice'. Despite, or as a consequence of,

this, the Bulletin Board is fairly solidly supported with expertise and assistance when required.

### Three Main Board Areas

The board consists of three main sections, the first of which is the help system. This provides you with ready assistance when you are unsure of how to use a function, or if you are not sure what commands are available to you. The second function is the board itself. This is the means of leaving notices, reading notices and using the mail facility. It is also the means of gaining access to the many programs that are available on the system. The third function is the communications processor. This communications package is the public domain package, XYAM, a more advanced version of Yet Another Modem.

Our Bulletin Board runs in a fairly healthy hardware environment, although this is under constant threat from the needs of other systems we operate. The system is based around an IEEE-696 (S-100) micro with a Godbout 6 MHz 8085/88 dual processor and 64 Kbytes of memory. At present we have a Fujitsu 20 Mbyte hard disk, and a Qume 20 cm double-sided, double-density floppy disk drive which is usually not on line. It is used mostly for archiving logs of use and maintenance. I/O is handled by a Godbout Interfacer 1 and System Support 1, which also controls the clock.

The software environment uses Assembler for critical communications routines, C for some utilities and

dBase for part of the file handling activity. The dBase utilities were originally experimental but have proven manageable and usable, so will probably remain – with enhancements.

### What You Need to Connect

Connecting to the Bulletin Board is a fairly straightforward process, requiring a computer, modem and communications software.

What sort of computer? Basically any machine which can handle ASCII standard characters. That may sound simplistic, but the least of the problems with connection are related to the computer. All it really needs is the ASCII standard and, of course, the ability to support communications. Some machines don't, but can be modified to do so. Others do not state that a port can be used for communications, but will do so if you connect your modem, with, say, an RS232 plug, and the appropriate software.

Modems are covered in another article in this issue, so I won't go into too much detail here. Needless to say, you must have one to communicate between computers using telephone lines. There are two kinds of modem: acoustically coupled and direct-connect. Direct-connect versions tend to cost, or tended to cost, a little more, but they are much better; the response of acoustic couplers tends to deteriorate over time. Modems are the major cost for computer users who want to set up for communications. They start at around \$150 and go beyond the

*If the number of calls we've had in recent months is any indication, there are a lot of people out there who are keen to find out as much as possible about the 'Your Computer' Bulletin Board. Evan McHugh, the system's new operator, explains what you'll need and what you have to do to become an active Bulletin Board member.*

\$500 mark. The variations in cost reflect the features you get and the person you buy the modem from. Some of the cheapies do give quite a good level of performance and should not be 'pooh poohed'. If you are not sure about getting into communications, one of these may prove suitable until you decide on a more fully featured modem.

Finally, there is the software. At the very basic level you need a package which will look at the communication port to see if a character has arrived. If it finds a character, it should take it and display it somewhere useful — like on the screen. Then it should take whatever you enter in reply at the keyboard and send it through the output line on the communications port. It really is that simple and doesn't require much programming knowledge to set up. At higher levels of sophistication you can set up the package to save all the interactions which take place in a file, so you can look at it later. This is particularly helpful if you have a disk system. You can, of course, connect up a printer and dump everything that transpires to it, but if you can save to a file you save paper and foster the concept of the electronic office.

At some time you are likely to be confronted by full-blown packages which permit file transfer, save data as requested and send things to printers for a record of activity. Having seen a friend go through around six months of mental anguish trying to get file transfer working, I've decided it is not the sort of project to undertake lightly. If you have a frail constitution, a file transfer program will probably break you.

Because the Bulletin Board operates at 300 baud you will find that BASIC programs handle simple communications with ease. However, if you get into more and more sophisticated activity, you may find the performance of BASIC inadequate, and decide you need something with greater capabilities — a package that is either in a compiled form or in another language such as Assembler, which is very

quick, or something like C. Some of the 'standard' communications packages are written in C and you may already have bought a C compiler to set them up.

The pricing of communications software is something to beware of. Bulletin boards are common because the people who wrote the software for the first one were not interested in profits and put the programs in the public domain. That means much of the stuff is free. However, people will try to sell you things that you can get from others for the cost of copying to a disk or cassette and mailing it to you. Dare I say it, you will be unlucky if you have to pay more than \$20 for a complete communications package.

If you can't get reasonably priced software from a retailer, you could try writing your own simple communications package; otherwise, contact the nearest computer club to see if they can get a copy of something in the public domain.

If you're really unfortunate you'll find you have a machine that will only run commercial software which could cost as much as \$500 a shot.

## The Board

Now you have your modem, your software and your computer all set up and your nervous fingers rest upon the telephone ready to open up the world of computer communications. A few more things need to be done. You must ensure that the protocols for data transfer are correctly set. Your communications package should clearly explain these settings (unless you've written it yourself). This is the way things should be:

- 8 data bits
- 1 stop bit
- no parity
- 300 baud
- full duplex

Your modem should be switched to 'originate mode' and the modem itself should comply with the CCITT V21 standard.



**Your Computer's  
Bulletin Board.**



# Cash & Carry Com

## IBM

	Our Price	R.R.P.
Symphony .....	775.00	995.00
Lotus 123 .....	545.00	895.00
Spell Binder .....	492.00	695.00
Supercalc 3 .....	367.00	445.00
dBase II .....	595.00	825.00
Multimate .....	495.00	595.00
Corporate MBA .....	1020.00	1200.00
Wordstar Propak .....	545.00	795.00
Open Access .....	675.00	940.00
Quickcode .....	300.00	380.00
Flight Simulator .....	69.95	87.95
Cardbox .....	279.00	328.00
Ada .....	360.00	420.00
C-Compiler CP/M86 .....	315.00	385.00
Fortran IV .....	499.00	578.00
Turbo Pascal .....	75.00	139.00
Single User Unix .....	1987.00	2392.00
Multi User Unix .....	2499.00	2925.00
Revelation .....	1499.00	1762.00
Knowledgeman .....	595.00	895.00
Hercules Graphics .....	595.00	938.00

**FOR ALL SOFTWARE REQUIREMENTS — CALL US NOW FOR SUPER SAVINGS!**

D Base III .....	625.00	795.00
Abstat .....	599.00	742.00
Stat pac .....	577.00	637.00
Pascal MT +86 .....	585.00	725.00
Concurrent CP/M 86 .....	508.00	610.00
C-Basic 86 .....	314.00	395.00
Basic Program Tools .....	295.00	370.00

Personal Pearl .....	435.00	510.00
Blue Linx SNA Emulation .....	1445.00	1890.00
Key II — 123 .....	375.00	427.50
BPS Graphics .....	488.00	562.50
STB Graphics .....	724.00	867.00
NBI Remington .....	990.00	1245.00
Jack 2 .....	690.00	770.00
PCOX .....	1707.00	1895.00
Havard Project Manager .....	559.00	658.50
Auto Cad .....	1523.00	1875.00
Micro Cad .....	876.00	982.00
K-Graph .....	349.00	510.00
K-Print .....	176.00	249.00
Peachtext 5000 .....	547.00	599.00
Peachtree Basic Acc System .....		
All AST Products .....		

Call for a price  
Call

## Commodore

	Our Price	R.R.P.
Commodore 64 .....	385.00	499.00
Commodore SX-64 .....	1299.00	1499.00
Commodore Vic 20 .....	224.00	229.00
1541 Disk Drive .....	385.00	499.00
Datasette .....	41.95	49.95
802 Printer .....	429.00	499.00
1701 Colour Monitor .....	429.00	499.00
Koala Pad .....	138.75	149.95
Multipan .....	128.00	149.00
The Manager .....	83.15	100.00
Easy Script .....	83.15	100.00
Home Accountant .....	87.95	105.00

## ATARI

Atari 600 XL .....	329.00	399.00
Atari 800 XL .....	545.00	599.00
Atari 1050 Disk Drive .....	625.00	699.00
Atari 1010 Program Rec .....	147.00	159.00
Atari Koala Pad .....	137.00	159.00
Atari Writer .....	103.95	119.95

## KAYPRO

Kaypro II  
Kaypro IV  
Kaypro X

**Call For Top Value**

**MAJOR BRAND COMPUTERS CALL NOW FOR TOP VALUE!!!**

## TeleVideo

Televideo PC .....	4695.00	5445.00
Televideo PC XT .....	7475.00	7975.00
Televideo Portable .....	4099.00	4444.00
Lotus 123 .....	400.00	895.00

with each Televideo (less than 1/2 price)

## TERMINALS

Qume 102 .....	1599.00	1730.00
Qume 103 .....	1976.00	2154.00
Intecolor 2405 .....	2142.00	2394.00
Intecolor 2427 .....	4208.00	4794.00
Televideo Personal Terminal .....	1047.00	1194.00
Carry Case for Terminal .....	126.00	135.00
Televideo 914 .....	1383.00	1495.20
Televideo 924 .....	1699.00	1892.00
KDS62 (VT 100 Emulation) .....	1090.00	1240.00
KDS62 (Televideo 950 Emulation) .....	1090.00	1240.00
TVT 6600 .....	800.00	1074.00
TVT 6600C .....	875.00	1194.00
Microterm Ergo 301 (VT 100) .....	1788.00	1902.00



**PRODUCTS NOT LISTED — CALL US FOR**

# Computers & Software



## OSBORNE

	Our Price	R.R.P.
Osborne 1 .....	1890.00	2180.00
Osborne Executive ...	2690.00	3180.00
Osborne Drive C .....		
Osborne Trantor 10mb		
Osborne Comm pac modem		
Osborne Web Network		

**CALL US  
FOR TOP  
PRICES**

## DISK DRIVES

	Call	Call
ACT Hard Disks .....		
Tallgrass Hard Disks		
12.5 mb w/ Tape backup.	4645.00	5161.00
20 mb w/ Tape backup.	5395.00	5994.00
35 mb w/ Tape backup.	7122.00	7913.00
IBM PC Disk Drive .....	395.00	635.00

## apple.

	CALL	CALL
Macintosh Software		
Apple CED Card par/ser.	97.50	135.00
Microsoft Softcard .....	422.00	545.00
Digitek Printmaster .....	128.00	202.00
CP/M + Wordstar + 64k.	<b>585.00</b>	745.00
Homeward .....	89.00	99.65
Zardaxx .....	256.00	324.00
PFS File Graph Report ...	146.00	175.00
dBase II .....	595.00	825.00
ALD System II .....	182.00	215.00
Microsoft Fortran .....	279.00	329.00
Microsoft Basic Compiler.	559.00	659.00
Peachtree MacCash ...	<b>255.00</b>	<b>275.00</b>
RGB for II+ & IIe .....	142.00	162.00
RGB & 80 col for IIe .....	189.00	234.00
Accelerator II (for II+) ..	811.00	990.00
Perfect Writer .....	<b>135.00</b>	450.00
5 mb Apple III .....	2759.00	3456.00
10 mb Apple III .....	3599.00	4554.00

## MISCELLANEOUS

64K Chips .....	90.00	135.00
Diskettes 5" .....	41.00	67.00
Printer Cable .....	54.00	73.00
Diskette File .....	35.00	62.00
Printer Paper 10" .....	52.00	80.00

## MODEMS

Cicada 300 .....	199.00	250.00
Cicada 300T .....	228.00	275.00
Cicada 300 (Commodore) .....	213.00	275.00

## MONITORS

Kaga Green IBM .....	307.00	327.00
Taxan Kaga Green .....	246.00	306.00
Taxan Kaga Amber .....	251.00	311.00
Roland RGB .....	872.00	995.00
Princeton Graphics (colour) .....	1049.00	1133.80
Princeton Graphics (Amber Max-12) .....	567.00	598.80

## PRINTERS

	Our Price	R.R.P.
Amust .....	356.00	449.00
C-Itoh 8510 par .....	993.00	1340.00
C-Itoh 1550 par .....	1245.00	1635.00
Star Gemini 10x .....	420.00	599.00
Star Gemini 15x .....	775.00	955.00
Star Delta 10x .....	775.00	955.00
Star Delta 15x .....	998.00	1434.00
Olivetti Praxis 35 .....	650.00	875.00
Olivetti Praxis 40 .....	775.00	995.00
Brother HR-15 par .....	675.00	895.00
Brother HR-25 par .....	1035.00	1345.00
HR-15/25 tractor feed ..	<b>148.00</b>	189.00
HR-15/25 Sheet Feeder..	<b>348.00</b>	449.00
Roland 8 Pen Plotter ...	1286.00	1395.00
Roland 1 Pen Plotter ...	795.00	895.00
Epson FX-100 .....	1287.00	1416.00
Epson RX-100 .....	863.00	960.00
Epson RX-80-FT .....	617.00	690.00
Epson RX-80 .....	499.00	558.00
Epson FX-80 .....	896.00	984.00
Epson LQ-1500 .....	1899.00	2262.00
Toshiba P1350 .....	2990.00	3504.00
Toshiba P1340 .....	1587.00	1740.00
Sheet Feeder for 1350 .	1476.00	1608.00
Tractor .....	249.00	282.00

**Cash & Carry  
Computers & Software**

**P.O. Box 696  
DARLINGHURST 2010  
(02) 331-3888**

**!!! PRICE WAR !!!  
CALL US LAST  
WITH YOUR  
BEST QUOTE.**

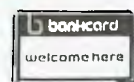

\$5 overnight delivery on most items.

All prices include Sales Tax. Prices subject to change without notice.

**EXCEPTIONAL PRICES**

## FRAMEWORK

Framework® is the first of a new generation of products that goes beyond today's integrated spreadsheets. It is an order of magnitude better than the original integrated products and windows.

The heart of Framework is a unique "frames" technology. Frames are actually self-contained, inter-related displays that can be nested, resized and relocated anywhere on the screen. Frames bring new flexibility to the way information is created and managed with a PC. With this truly three-dimensional design, the user can create infinite logical hierarchies of information, leading to as deep a level of complexity as needed for the task at hand. There is no limit to the number of frames that are active in the system. Framework's user interface is one of the most elegant designs yet conceived.

### Word Processing

Framework's word processor is dynamite! It gives users the choice of frame or fullscreen viewing of documents, multiple margins within a single file, automatic justification and repagination, header/footers, page numbers and more. The streamlined menu system helps new users get started in a hurry and "shorthand" commands help veterans work even faster.

### Outlining

The innovative and very powerful outline processor can be used as a standalone organizer or as a companion to the word processor. Using this outline mode, single ideas can be quickly captured and then expanded into fuller concepts and solutions. Any outline-frame or subheading within an outline can be instantly expanded to include text, spreadsheets, graphs or databases. Finally, with Framework, your PC is truly a thinking machine.

### Database

Framework's database system can be learned quickly and put through its paces effortlessly because most commands are common throughout the entire program. Framework itself will handle most of your analytical information management needs, and if very large data handling is required, Framework is fully compatible with dBASE II®.

## Spreadsheet

Spreadsheets are simple to create, use traditional row/column or English-language cell addresses, can be linked to automatically update other files based on cell data and have an exclusive international numerics feature that will change entries to accurately reflect changes in currency denominations including the placement of commas and decimal points.

## Graphics

The graphics portion of Framework has been designed to produce exceptional charts and graphs on standard monochrome monitors. Six of the most frequently used business graphs are built-in and can be automatically drawn and updated from data in spreadsheets and database files.

## DOS Access

The new DOS access capability allows any user to actually run other PC DOS software inside Framework. This allows users to gather data from other programs without quitting Framework. It will be of great help to people who frequently shuttle between programs and to businesses who perform frequent interchange of programs or data with larger systems.

## Custom Applications

Framework comes complete with its own programming language. Users can begin writing their own custom packages or use software developers right away. In addition, dealers will continue to receive the excellent support that

has helped make Ashton-Tate the front-runner in the software industry with dBASE II and FRIDAY!

## Hardware

Framework will run on the IBM PC, PC XT and all compatibles. It requires just 256K RAM and dual 360Kb floppy disk drives with monochrome display.

## Availability

Framework will be available in Australia from the end of July. Contact your dealer end-June for more details or write to the Master Distributor, ARCOMPACIFIC, Freeport 2 (no stamp required), P.O. Box 13, Clayfield, Qld. 4011.

# ASHTON-TATE



**arcompacific**  
software distributors & wholesalers  
**master distributors**

Now you're ready to go. The Bulletin Board telephone number is (02) 662 1686. When the phone answers, usually after about two rings, there will be a short pause and then you'll hear a high-pitched tone followed a couple of seconds later by a lower-pitched, continuous tone. This is the carrier signal from the Bulletin Board. Connect the line to the computer and, if all is going well, you should see the following question on your screen:

How many nulls (0-9) do you need? \_

What the system is asking is how many nulls you want the Bulletin Board to send at the start of each line. This is because some computers with slow screens 'miss' the first few characters of an incoming line (while they are returning from the end of the previous line to the left edge of the screen): to ensure that nothing meaningful is lost, the nulls come down the line to create a delay while the screen catches up. Most people can put a 0 in response to this question. If you find that you are losing the first few characters of each line increase the number of nulls.

When you type your 0 the system should respond with a new question. If the same question is repeated it means we did not get your character correctly and something is amiss. In this case you should check to see you have set up your system correctly, according to the protocol mentioned, and that all the components are correctly connected.

The Bulletin Board will ask if your terminal can display lower case, and then it will want to know your first and last names. The system will check this against the log of all callers who have ever connected to the board. If you have never logged on before you will be put through a short survey to determine who you are, where you come from, what sort of system you have and what aspects of computing you are interested in. This is a once-only survey, after which you will be taken straight into the CP/M level of the system.

You know you are at the operating system level when you get a CP/M prompt: 0A>. The Bulletin Board CP/M system is restricted, in that all commands which could be used to damage the system have been removed. I don't intend to document the CP/M system, since there are enough manuals around to explain it to you. We've listed some of the CP/M commands in this article.

To call up a list of the utilities you

## CP/M Commands on the Bulletin Board

**HELP** - invokes the help system, paging various .HLP files for you. Syntax is HELP <filename> where <filename> is a file with an extension of .HLP (you don't type the .HLP). Current help files include QUICK (instant command summary), BOARD, CLUB, MODEM, PROGRAMS, THIS-SYS, and HELP (a description of the HELP program).

**DIR** - lets you look at the files currently on the selected drive and user area.

**TYPE** - lets you view the contents of a file. It has several usages. TYPE name lets you display any CP/M text file. \* and ? are allowed as wildcard file definitions. TYPE name nn gives the starting line number for typing. TYPE name # gives a count of the number of lines. TYPE name label skips to the label before printing. This must match exactly and completely. To match leading characters end the string with \*, for example, TYPE b:foo.asm tr\*

**x:** - lets you change the currently selected drive. Possible drives are A, B and C while the hard disk is running, A and B when the system is on floppies. At the moment, we are about to put it back on floppies for a limited period (the hard disk was on loan from another section of the company, and has been 'recalled'. We have another, but need a power supply and disk controller for it.)

**CHAT** - beeps the console bell at our end. If someone is around and has the time (rare in office hours) they can initiate a keyboard-to-keyboard conversation with you.

**FIND** - searches files for a specified string. Syntax is FIND <filespec> search-string [|secondstring]. Filespec can be a single filename, or a valid CP/M wildcard file specification. If you include a second string with the vertical bar delimiter it will search for either string in the specified files.

**FLIP** - depending on which modem we have connected, this will switch from ANSWER to ORIGINATE mode, or vice versa. Sometimes useful if you have a bad phone line. If it doesn't work, we have the wrong modem connected ...

**XYAM** - the system communications utility. Uses Christensen protocol, compatible with YAM, MODEM7 and others.

**BYE, OFF, LOGOFF, QUIT** - log-off the system.

**Message system commands from within the BOARD program:**

**MENU** - Go to the board's menu system.

**LOGOFF** - log off the system.

**?** - display a summary of board commands.

**PASSWORD** - Alter your password (members only).

**CPM** - Go to CP/M.

**BACK** - Return to the previous program.

**NEW** - New system information (not yet implemented).

**EXP** - Toggle expert user mode (brief prompts).

**PROGRAMS** - view/download YC magazine programs (members only).

**Or you can select from the table below:**

	Menu	Place	View	Delete
Adverts	MADV	PADV	VADV	DADV
Notices	MNOTE	PNOTE	VNOTE	DNOTE
Meetings	MMEET	PMEET	VMEET	DMEET
Mail	MMAIL	PMAIL	VMAIL	DMAIL



**IMAGINEERING™**

"The Art of Software"

*presents*

## **THE TIME SPECTRUM™**

**"ADD UP TO 512K RAM, ASYNC AND SYNC COMMUNICATIONS, A CLOCK AND PRINTER SUPPORT-UP TO FOUR I/O PORTS IN JUST ONE SLOT."**



**PERSYST™**

**Available for the IBM PC & XT at all fine microcomputer outlets  
IMAGINEERING, 579 HARRIS STREET, ULTIMO, N.S.W. 2007. TELEPHONE: (02) 212 1411**

can execute, type DIR. This will give a DIRectory of the files on the currently logged drive and user area. You can execute any of the COM files and you can look at help files by typing HELP <helpfilename>.

To enter the Bulletin Board, which is the main system, you simply type Board. You will then be asked for your ID-code. If you are a member of the board you will have been given a user number. Type the number, a dash and a six letter password to gain access to the board. If you are not a member, you can type 'visitor' to gain access.

## Visitors

Visitors are entered on a restricted entry level which only allows them to look at the public areas of the board; they are not able to look at the programs section, private mail, or leave any messages or advertisements. If you do wish to leave a comment to the sysop you can do so by leaving a comment when asked at the end of the session. At the end of this article we will outline the way you become a member of the Bulletin Board.

Once you have entered the Board you will be asked to enter a command. Valid commands, brace yourself, are: VADV, PADV, DADV, VNOTE, PNOTE, DNOTE, VMEET, PMEET, DMEET, VMAIL, PMAIL, DMAIL and PROGRAMS. There are others but these will do for now. These are the commands that actually take you into the facilities of the board.

## The Four Commands

You may have noticed that there are four basic types of command, ADV, NOTE, MEET and MAIL. These are for Advertisements, Notices, Meetings and Private Mail. Each of these is preceded by a V, P or D, which stand for view, place and delete respectively. So, what you are able to do is look at, leave or delete any of the four types of message that the system supports. All you have to do is type the command and you will activate that function. There are also M commands which take you into the menu-driven system, if you are not confident about issuing commands.

Advertisements are ads left by members selling anything from computers to pavlovas. They usually include a phone number or member number to contact. Notices are just information on general topics which members think everyone should know about; say a new product release, or a fixed bug on a popular system. Meetings is a section where clubs

The Bulletin Board's new sysop, Evan McHugh, showing off his 'baby'.



leave the time, date and place of their next meeting. Mail is the private mail system where members pass messages to one another.

If you choose to view something you will be asked which message on the system you want to retrieve, whether you want a quick scan of what is there, or whether you want to return to the board. A scan will list all messages on that system and their number. When you have decided which ones you want to look at, you can specify them using the retrieve command and they will be displayed for you. You can also look at multiple messages, or get a quick summary of what messages are available.

To place a message, use the P option. If you are leaving an ad, notice or details of a meeting, the number of the message will be supplied and it will automatically be put into the correct area. All you then do is enter the text and hit return at the beginning of a new line to exit. In the case of leaving mail for someone, you will also have to specify the member number of the person to whom you want the message sent.

When deleting messages, you are only able to delete notices, meetings and advertisements that you have left. If you do not do so after the message has become irrelevant, it

will be done for you by a sysop. It is preferable if you do your own deleting, in the interests of a tidier system. You can only delete mail that has been sent to you, not mail that you have sent. When deleting, all messages numbered above the one you have deleted will reduce by one, so numbers are always continuous.

To look at the programs, all you do is execute the PROGRAMS statement from within the board. This will take you into area 3C> at the CP/M level. Doing a DIRectory will show all the programs you are free to download. To look at a program, just LIST or TYPE it. To get a copy of a program you will need to use the XYAM utility which will be described in a moment.

To return to the board, just type BOARD REENTER and you will be taken back to the bulletin board command line. When you have finished with the board there are two ways to leave it: the first is by typing CP/M, which will take you back to the CP/M level and area 0A>; the other way is to type LOGOFF, which will generate the question 'Do you want to leave any comments? (Y or N)'. At this point an N will exit you from the system, while typing Y will let you leave a comment which will be terminated when you hit return at the beginning of a line. Once this has been done, you will also be exited from the system. If you are

## Bulletin Boards

using the menu system, entering 99 will give you a log-off.

### Downloading Programs

Once you have seen what there is in the programs section, you will probably want to transfer some of the files for use on your own computer. None of the programs is executable on the board itself; you can only run them at your end.

If you want a copy of a program, one way of getting it is to list it and store it in a buffer as it comes down the line. The danger with this method is that any glitches which hit the data as it comes down the line may cause havoc when you try to run the program. So, you need a file transfer utility with error checking, like Modem7 or YAM (Yet Another Modem).

The utility we use is called XYAM. It works by sending 128-byte blocks and then a checksum which must match up with the calculated value at

the receiving end before the next block is sent. If the values don't match, the block is sent again. If after ten attempts the block still does not get through, the utility assumes the line is inadequate for successful data transmission and gives up. If this happens you can try redialling in the hope of getting a better line.

To run XYAM, all you have to do is type XYAM at the CP/M level. This will bring you to the prompt xYAM(A0). You can send and receive files in various formats using XYAM, and you can initiate CHATs with the sysop. The normal file transfer procedure is to send with checksum or receive with checksum. When doing either, you have to issue instructions at both ends of the communication line; that is, at the Bulletin Board end and at your end.

If you want to send a file to the board, you issue an 'r filename' which will tell the board to receive data and put it into whatever file you gave as the filename. To send the file, you have to switch to your end and issue the command 's filename'. You need to be fairly quick with this second command, as the system will give up on you if it does not receive any data. You have about 30 seconds.

To get a file from the board, simply reverse the process: issue an 'r filename' at your end and then an 's filename' to the board.

Note that filenames are in the form eight characters, a fullstop, and three characters. Command files (.COM) are executable under CP/M, and we do not want people trying to load files and execute them on the system. Consequently, they will be changed to OBJ files by the file transfer utility. There are other conventions for naming programs, so that people can determine what machine they are for. These are listed under the HELP PROGRAMS on-line Help screen.

To exit from XYAM you can type BYE or QUIT. Bye will take you out of the Board, while quit will return you to the CP/M level.

### Help

Finally, there is the HELP system. The HELP messages in this system are very comprehensive. At almost every point you can get a full explanation of the system by typing HELP or some other command such as a question mark. Both the board and XYAM have help screens. At the CP/M level there are numerous screens available. They can be

## LOW COST DREAMDISK SYSTEM FOR YOUR MICROBEE.

**\$799  
INC. TAX**

### The system that out-performs the others—

**1. Versatile:** runs on any model MicroBee 16, 32 or 64k system running CP/M or our BeeDOS (Basic Disk Operating System). Drives may be single or double sided, and 5.25" or 8". Under CP/M (32 & 64k Bees), logical drive assignments are fully supported, giving single and multiple drive users best use of their systems. Our unique BeeDOS gives 16 & 32k machines full access to disks for storage of BASIC programs and data, WordBee files and machine language games.

**2. Power:** Up to 4 drives 8" or 5.25". Standard 40 track 5.25 inch drives give 390k of storage, the new 80 track drives give 790k, and 8 inch drives can give up to 1376k.

**3. Compatible:** with MicroBee disk system and many other CP/M formats. Our 80 track systems can read 80 and 40 track formats.

<b>DREAMDISK CONTROLLER</b> (controller card, all ROMs and manuals)	<b>\$299</b>
<b>COMPLETE SINGLE DRIVE SYSTEM</b> (includes controller, 40 track 5.25" drive, all cables, ROMs and manuals)	<b>\$799</b>
<b>SINGLE 80 TRACK SYSTEM</b> (as above, but with an 80 track drive instead)	<b>\$880</b>
<b>DUAL DRIVE SYSTEM</b> (as for single drive system, plus another 40 track 5.25" drive)	<b>\$1050</b>

**Add on 40 track drive \$300**  
**Add on 80 track drive \$380**

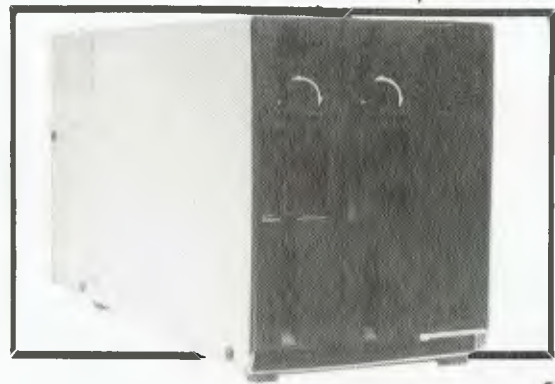

## DREAMDISK

171 Moray St. South Melbourne, 3205,  
Phone (03) 690 8283.

Write or Phone for more information:

# New from Software City.

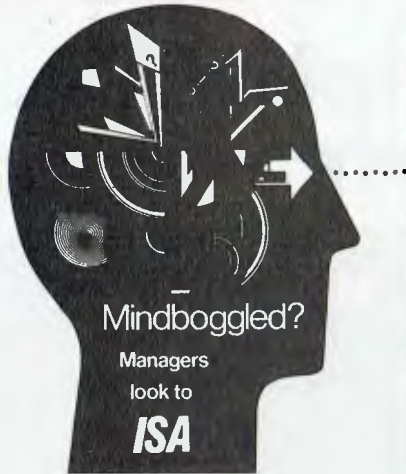

*We have the tools to do the job!*

- 13 times faster than dBase II
- Menu driven for ease of use
- Save report formats
- On-screen editing
- Fast set-up, formatting
- Full arithmetic functions
- Prints reports, mailing labels
- Posts transactions
- Sorts full disks up to 40 fields
- Search by string, range, comparison
- Price \$299.00 incl tax

SUPER is available for IBM-PC/XT, TRS 80's, CP/M and MS-DOS systems.

## Turbo Toolbox<sup>®</sup>

We've crafted some special tools to help you create the best PASCAL programs in the least amount of time.

Designed to complement the power and speed of TURBO PASCAL. These are functioning modules. Whether you're writing a database, an address book or any other application where you need to search or sort ... you'll appreciate Turbo Toolbox.

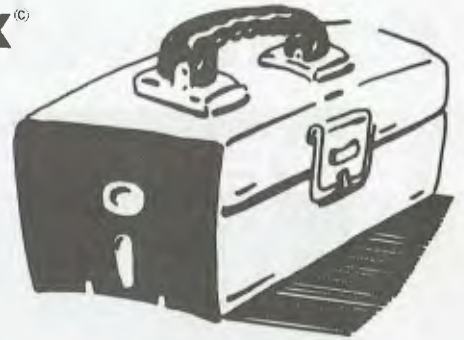

ONLY \$79.95  
Tax incl.

**BORLAND**  
INTERNATIONAL



## TURBO PASCAL<sup>®</sup>

And Now It's Even Better Than You've Heard!

- Automatic Overlays
- No licence Fees.
- A Full-Screen Editor that's even better than ever
- Full Heap Management - via dispose procedure
- Full Support of Operating System Facilities
- Windowing Color, Sound and Graphics Support (IBM PC)
- Optional 8087 Support (available at an additional charge)

JUST RELEASED

VERSION 2.0

\$79.95  
incl. Tax

## C/80 Version 3.1 now available

Fast C-Compiler with expanded runtime library, absolute assembler included.

**BEST BUY - \$79.95**

Dealer enquiries welcome.

AUSTRALIAN DISTRIBUTOR

**Software City**  
PHONE (02) 621 4242  
(02) 671 6951  
1/27 Forge Street, BLACKTOWN  
MAIL: P.O. Box 62, BLACKTOWN. 2148

## The Software Toolworks

A SOFT BUY  
IN A HARD WORLD



Introducing  
**MyCalc**

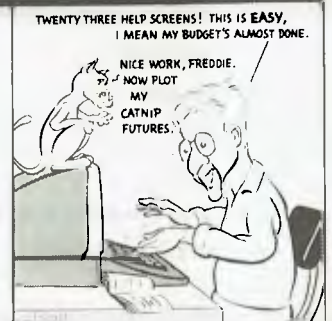

You'll be writing your first Spreadsheet the day you buy MyCalc **only \$99.95 incl. tax**

## Computer Gourmet Cooking.

Computer Chef, The Best of Wok Talk \$54.95 each, add 200 more recipes with What's for Dinner \$49.95.

Send big SAE For Big Catalogue of Top International Software.

# **P**ACESETTER

**Professionals in Peripherals.**

**SILVER-REED Daisy Wheel Printers**

**17CPS**

**25CPS**

**40CPS**

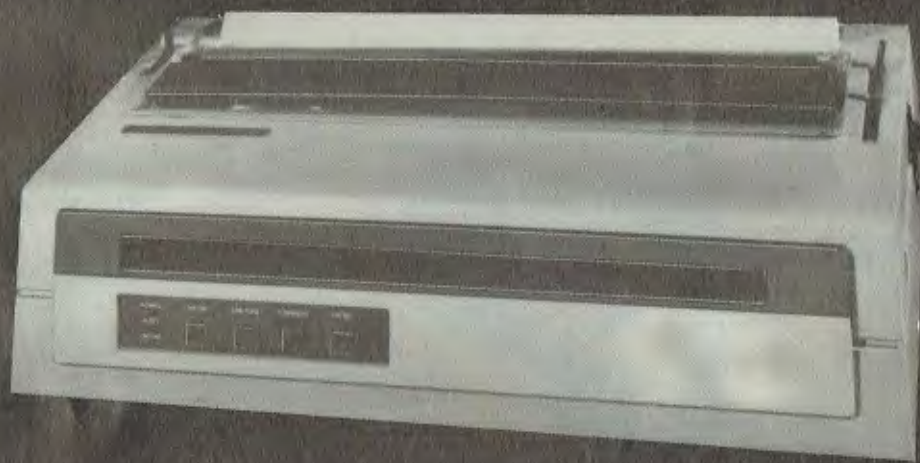

- \* Variety of Speeds
- \* Quiet operation
- \* Versatile
- \* Dependable
- \* Compact space-saving design
- \* Complete range available
- \* Options

## **Special Features**

- \* First rate letter quality
- \* Bidirectional
- \* 17-40CPS
- \* 13-17" Paper widths
- \* Self test function

- \* Supports a full range of word processing functions including bold print, subscript, superscript plus underlining functions.
- \* Daisy Wheel and Ribbon Cartridges can be changed easily, quickly and cleanly.

\*Prices do not include sales tax

**Our prices to OEMs and Dealers are EVEN BETTER!**

FOR FURTHER INFORMATION CONTACT:



**PACESETTER  
PERIPHERALS**

A division of VSI Electronics (Australia) Pty. Ltd. (Incorporated in S.A.)  
16 Dickson Avenue, ARTARMON 2064, N.S.W. PHONE: (02) 439 4655

Adelaide (08) 267 4848 Brisbane (07) 229 8827 Melbourne (03) 818 0688 Perth (09) 328 8499

accessed either by typing HELP as mentioned, which will give you a guide to the help system, or by issuing a command such as HELP PROGRAMS which will take you into the help information for a particular aspect of the system. Apart from the programs help there are THIS-SYS, BOARD, MODEM and CLUB.

### Administrative Details

Hopefully, you now have enough information to begin navigating the Bulletin Board. Using this, and the information provided by the system, you should have few problems. There are some other things worth mentioning, however.

First, if you have a problem don't hesitate to contact us, either by phone or through the system. You can leave a comment at the end of your session when asked, or, if you are a member, you can send mail to Member 1. For more immediate assistance you can try using the CHAT facility. This opens up a communication link to the sysop (if I am nearby and available). Don't use this unless you have to, as we are often pretty busy and must interrupt our work to answer your call.

Membership to the Bulletin Board costs \$20 a year. If you want to become a member you should send the annual fee, along with your request for membership, your name, address and phone number, to *Your Computer*, 140 Joynton Avenue, Waterloo 2017.

From time to time we get people who access the board and leave messages or files that are obscene or destructive to other users when

run. So, be careful of the files you copy - they may be dangerous. If you can, get an idea of what a program does before you run it. When we become aware of such programs they are deleted, so let us know if something is amiss.

Also, to the people out there who leave messages containing obscenities and abuse, please keep sending them to us. It takes us half a second to delete them, and we get a kick out of knowing it cost a person like you at least 13 cents for the 'big thrill' of leaving swear words on a computer. If you are in the middle of leaving your little mark on the system, don't be surprised if you get cut off - we are frequently watching.

Another warning is about putting copyrighted software up on the board. That is not on. All software loaded to us should be in the public domain. Programs in the public domain are intended to be used for non-commercial purposes, and the copyright remains with the person who placed it in the public domain, who also retains marketing rights. At present the system is open for exchange of public domain software, but if it is found that copyright software is being passed over the system, drastic measures will be taken. While covering the perils of the board, I should mention that members must protect their own passwords. When on the board, you should regularly change your password to prevent illegal access. This is simply done, by typing PASSWORD while logged into the board and supplying your new password.

One last feature on the board,

## Bulletin Boards

which we hope will be of use, is the list of Australian Bulletin Boards. You can get to this by typing B: and then looking at AUSTPAM.DOC.

### Coming Developments

At the moment, the system is in a state of equilibrium, with fairly efficient operation, but we do have some developments planned for the near future.

The Bulletin Board aims to provide a meeting place for people with the shared interest of computing. It is hoped that it will encourage the exchange of information between computer users who might not normally be able to contact each other. The only way to take advantage of what it has to offer is to make frequent and extensive use of it. If you are experienced in some area or other, you can use the board to allow others to benefit from your knowledge.

Bulletin boards are springing up all over the country. They are fairly easy to set up and maintain, and relatively easy to access and benefit from. It is a growing area of microcomputing with a firm foothold and a solid future. If you decide to take the plunge, you should get a lot of satisfaction and reward from communicating by computer. We look forward to hearing from you.



## FUJI FILM FLOPPY DISKS BRING PEOPLE, INFORMATION AND MEDIA TOGETHER



### RD Binder System.

The RD (reliable and durable) Binder System--developed under FUJI FILM's own technology--is what gives FUJI FILM floppy disks their incredible toughness and stability. It acts as the adhesive which binds the magnetic particles together and to the tape base. The system ensures uniform dispersion of the magnetic particles using a "Three Dimensional Network Structure".

Our disks provide greater durability during repeated use, and are weather-proofed, ensuring peak performance even under severe environmental conditions.

Three Dimensional Network Structure



### Contact Your Local Supplier

GOODMAN CANNINGTON (Aust.) P/L  
Melbourne (03) 241 1341  
EMPIRE OFFICE SUPPLIES P/L  
Sydney (02) 560 4444

Trade Enquiries Fujimex (02) 938 0241



# One stands head and shoulders above the rest.

Amongst the growing number of IBM\* compatible personal computers, there are a lot of major differences.

All offer similar power, and are capable of performing almost identical functions. The best one, however, must not only be industry standard software and hardware compatible, but also offer a total package. That alone eliminates about 85% of the roses in the garden.

The fact that the best one will also offer a free 3-month warranty plus, for a token amount for registered users, an additional 9-month warranty, and the maintenance back-up of Sigma Data that enables on-site care is quite unique.

Most of the remaining roses are looking very tired now.

The best one will also offer a more functional design for the users' ease. A footprint that takes up less desk space. And a choice of screens that tilt and swivel with push-button mono/colour control.

The best one will offer a choice of operating systems, including the latest Concurrent CP/M-DOS<sup>†</sup>, an optional hard disk model, and an extensive range of business software.

If you could find two roses offering all this, then the best one would be the least expensive.

And that's the Elite from Sigma Data. To compare our rose with the rest of the garden, phone Sigma Data, Sydney on (02) 439 6211.

**Elite**

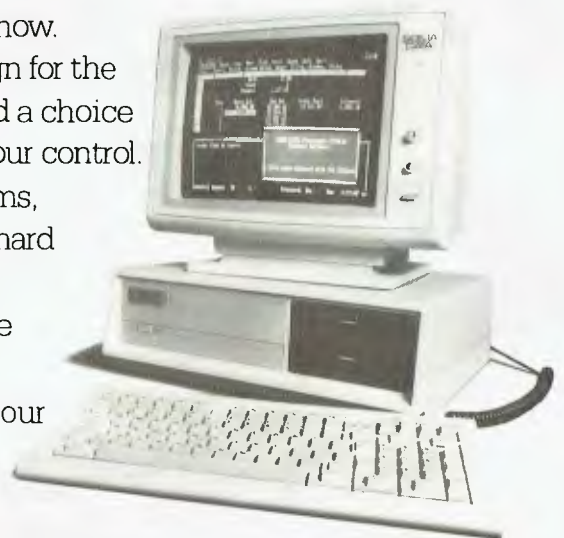

\*IBM is a registered trade mark of International Business Machines Corp. †Registered trade mark of Digital Research.

Stewart Roache Watson SDC041

# DATA COMMUNICATIONS

*While not unfamiliar with the world of electronics, Cathy Gray, the editor of 'Sonics' magazine, considers her expertise lies more in the area of musical instruments, and sound and lighting production for concerts. The need to keep abreast of overseas advances in 'entertainment technology' prompted her to try computer communications. As she says here, it's faster than the mail, and produces a more concrete result than telephoning.*

AS EDITOR of a music technology magazine, the idea of conversing with Los Angeles via computer keyboard would not have entered my head six months ago. Yet here I am happily dialling 20991 every week, waiting for the now-familiar 'carrier tone', typing terminal identifiers, interminable strings of log-in numbers and my very own password, and finally reading and sending 'mail' through a system of electronic mailboxes. Talk about jumping in at the deep end!

It's a bit like learning to drive a car, I guess, or following a recipe: it's possible to make the thing turn a corner, or rise and taste like bananas, or drop a letter lightning-fast into someone else's 'mailbox', without having a clue about the workings of the engine, the chemical composition of baking powder, or the meaning of the word 'modern'. You just do what you're told.

I'm sure *Your Computer* readers are way beyond this stage, but I need to impress upon you that I'm not a particularly experienced computer-user; in fact I'm just a shade off computer illiterate. I have, however, been successfully plugged into an international communications network since May and it's been very helpful.

## All Things Musical

This network is called IMC – International Management Communications – and is almost exclusively used by the music-related entertainment industry. IMC leases services and equipment from ITT Dialcom in the USA (as do networks like The Source, which you've probably come across, and Compuserve). IMC subscribers include concert production companies, tour managers, sound and lighting companies, promoters, studios, even musicians; and as well as individual mailboxes, it offers a 'bulletin board' with categories like audio, customs, drums, freight/trucking,

## Talking to L.A.

guitars, hotels, instruments offered/wanted, legal, lighting, restaurants, venues, jobs and jokes! If it's entered your head that you could use the network to find out when Bruce Springsteen is *really* touring Oz, don't try; it's all thoroughly password-protected!

My main interest in this system, however, is not the IMC network itself, but a group which sub-leases a series of mailboxes from the IMC. This is the International MIDI Association (IMA).

MIDI stands for Musical Instrument Digital Interface – a standard protocol agreed upon by major synthesiser manufacturers which, theoretically anyway, allows different brands of digitally controlled instruments to talk to one another (a concept from which the computer industry could learn, I gather). The IMA is a sort of user group/information source set up to keep people up-to-date on the implementation of the standard, as well as to allow them to share experiences and solve individual problems. It's the source of the most current information in a rapidly evolving area of music-making technology, and I wanted fast access to it. What better way than on-line?

So, after a lengthy instructional telex from the IMA co-ordinator and a lot of help from the staff of *Your Computer*, I leased a 'box' from the IMC, via the IMA, and away I went.

## All That Way ...

First time on, I was a touch awe-struck by the concept of a link-up with such a far-away land, and the initial messages read like telegrams from the South Pole, but it's amazing how chatty and intimate you end up



feeling about it all – and it's so much more efficient than a straight phone call, 'cause you end up with a file or a printout as a record.

Simply put, I'm sold. I'm gradually learning more about the workings of the system as I go, and there's even talk of setting up an electronic publishing network with input from Australia, the USA and the UK. I'm still dependent on the good graces of various *Your Computer* assistant editors for finding my way around YAMS and copying files and changing printers and so on, but I'll get there, and it's certainly broken down most of my initial feelings of high-tech-communications inadequacy.

For anyone who would like further information on these particular networks, the address of the IMC is 183 N. Martel #205, Los Angeles, California 90036 USA, phone (213) 937 0347; and you can contact the iMA at 8426 Vine Valley Drive, Sun Valley, California 91352 USA, phone (818) 767 0597.

It's worth noting, too, that Australia is about to get its own entertainment industry network, to be called AMC, membership of which will automatically put you onto IMC. The address to contact is PO Box 171, St Peters 2044, phone (c/- Jands Pty Ltd) (02) 516 3622. □

HOLLYWOOD

America's  
leading  
distributor of  
IBM P-C  
accessories  
is now  
supplying  
your  
IBM dealer  
locally. . .

Heralding  
this announcement  
is the introduction  
of the Qubie'  
10 Megabyte  
Winchester Hard  
Disk Drive for  
the PC-1 & PC-2  
**QUBIE' PC10**  
with 10 Megabyte  
hard disk, controller,  
cables, installation  
hardware and  
instructions.  
1 year warranty.  
**\$1,995** inc. tax

**NOW IN  
AUSTRALIA  
QUBIE'**

Also available: IBM PC key boards, multifunction memory boards and Modems.

**NOW IN AUSTRALIA:** 9/62 Blackshaw Avenue, Mortdale, 2223 - Phone: (02) 579 3322

**U.S.A.:** 4809 Calle Alto, Camarillo, CA 93010

**U.K.:** Tempo House, 15 Falcon Road, London, SW11 2PH, United Kingdom

**your**

October 1984

# **BUSINESS**

**MAGAZINE**

# **computer**

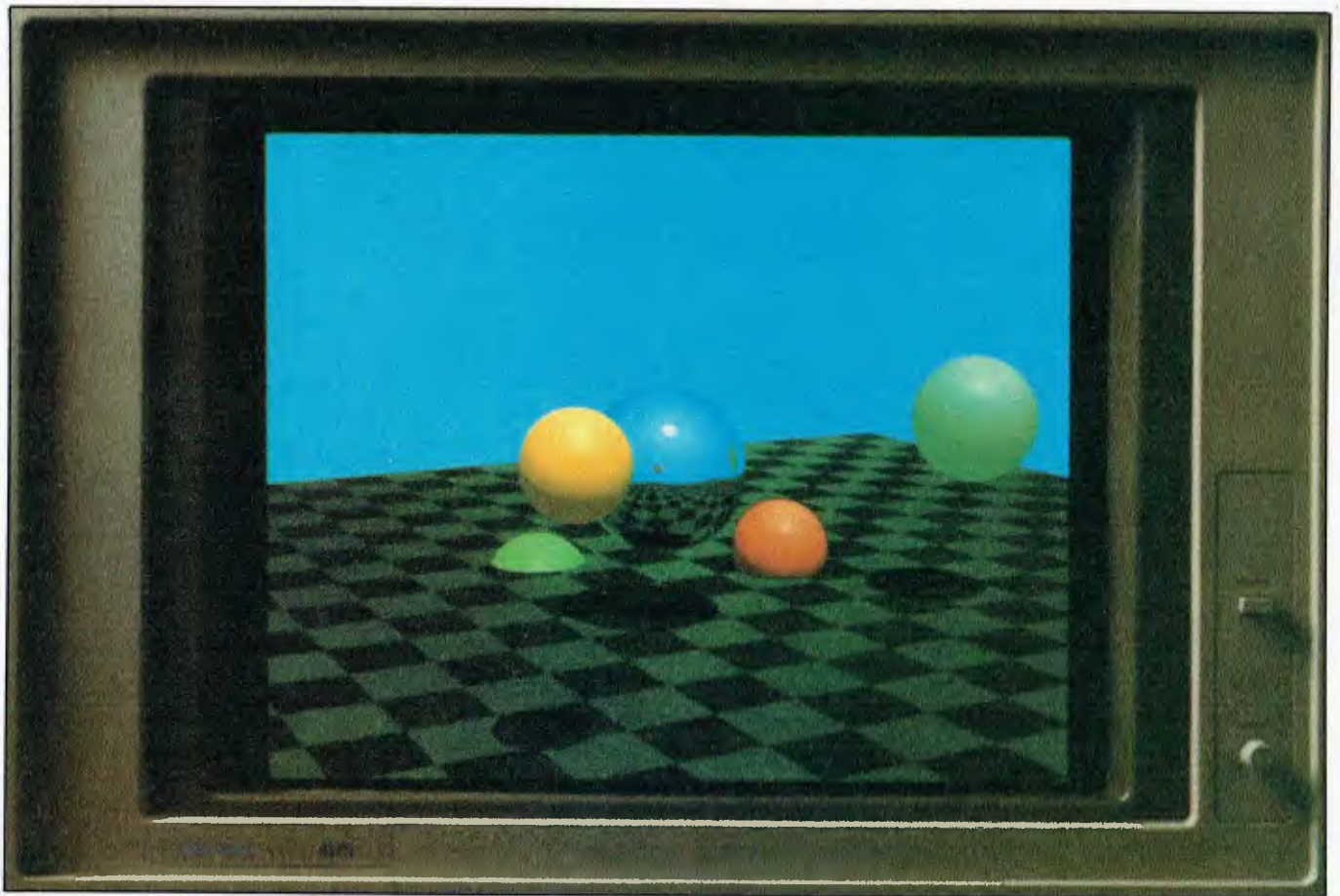

## **TERMINALS**

**Are You Dumb or Smart?**

---

**Corporate MBA Reviewed**

**Unusual Applications**

# The Freedom 200

Designed with your application in mind, the Freedom 200 has 43 user programmable non-volatile keys, clustered for maximum operator efficiency.

- **PLUS** 11 cursor control keys, including tab by word for easy editing.
- **PLUS** flexible non-volatile set-up modes, full page or status line, to easily configure your terminal exactly the way you want it.
- **PLUS** user-definable smooth scrolling regions, with selectable scroll rates.
- **PLUS** split-screen capability.
- **PLUS** 120 ASCII characters, with 86 extended graphic characters for forms creation.
- **PLUS** non-embedded attributes (visual and data entry).
- **PLUS** double-high/double-wide characters.
- **PLUS** programmable time out, to prolong the life of your screen
- **PLUS** easy serviceability, and space for add-on boards.
- **PLUS** two-page standard memory in emulation modes and one-page memory in native mode with additional memory optional.
- **PLUS** TeleVideo 950 and Lear Siegler ADM 31 emulations.
- **PLUS** excellent OEM discounts.
- **PLUS** more.



To find out more, contact your Liberty distributor.

Or call Moncrieff direct  
Sydney (02) 923 2211  
Perth (09) 325 5722

No other VDT  
gives you more,  
for less.

 **LIBERTY**



# Moncrieff

EXCELLENCE IN ELECTRONICS

**W.J. MONCRIEFF PTY. LTD.**  
176 Wittenoom Street, East Perth 6000  
Phone (09) 325 5722 Telex: AA 93022  
Cables & Telegrams: "CRIEFF", PERTH

8th Floor, 275 Alfred Street, North Sydney 2060.  
Phone (02) 923 2211 Telex: AA 71270

Distributors:

NSW - Pace Computers Services 02 411 7888 SA - Applied Data Control 08 799 211 TAS - Management Technology 002 344 522

*Is your computerised information safe from prying eyes and manipulating fingers? Our US correspondent took an objective look at the tendency to sensationalise issues such as computer break-ins, and to forget the basics of password protection.*

# Computer Security

BY HOWARD A. KARTEN

**T**he proliferation of microcomputers has given us media folk a chance to indulge ourselves in one of our favourite pastimes: the computer scare story guaranteed to scare the pants off most readers. (Why we love these types of articles so much is an interesting story in itself, but one for another place and time.) However, business computer users should not be over-alarmed by scare stories of precocious ten-year-olds making free with their data, merrily destroying or changing whatever they wish. The reality is that breaking in is a lot more difficult than they'd have you believe.

To be sure, there are real computer break-ins. There always have been, and always will be. However, reports in the popular press are invariably over-dramatised.

I have a theory that this situation arises from three co-operating sources: misunderstanding by reporters (and their editors) of what's involved; the natural tendency reporters have to turn to 'experts' and consultants for additional information; and self-serving misrepresentation by break-in victims.

Last year's big break-in story, on a group of bright Milwaukee youths (the '414s'), is a good illustration.

This group of youngsters succeeded in using the Telenet communications network to penetrate computers across the country. (Telenet is an enhanced packet-switching communications service used primarily by businesses. It affords a convenient, hassle-free way for customers or users to reach the computers connected to Telenet. Thus, Telenet is simply a service — a means to an end — like any other communications service.) Reporters on daily and weekly business publications across the country immediately seized on the Telenet angle in covering the break-in story.

The fact, however, is that Telenet was just as much a victim as the companies whose computers were broken into. Some reporters questioned why Telenet security was not tighter. In fact, tighter security would defeat much of Telenet's purpose, which is to act as a common carrier.

## 'Experts' a Mixed Blessing

We reporters frequently turn to experts

and consultants to help us understand some news development. This is not an unmixed blessing. On the one hand, consultants are frequently more adept at explaining things than users or victims. (This is true because a large part of any consultant's success comes from his or her ability to explain, persuade, sell and so on.) Also, consultants are viewed as having somewhat more objectivity than someone closer to a news story.

On the other hand, consultants — specifically, security consultants — do indeed have a vested interest in crying wolf. Persuading the public — that is, consumers — that the threat is real, immediate, and significant, is not a bad way of generating business. So who can blame them for giving in to the natural temptation to hype things up a bit?

Break-in victims, too, contribute to the situation. It's not hard to imagine the following conversation:

**Reporter:** Mr Manager, do you have any idea how these kids penetrated your computer?

**Manager:** Damned if I know. We have tight security here.

Here's a translation of what's probably really going on in that conversation:

**Reporter:** Mr Manager, you work for a sophisticated company with fancy, multi-million dollar computers. Do you have any idea how a bunch of mere high school lads managed to penetrate your computer?

**Manager:** You must be crazy if you think I'll spill the beans. If I told you the truth — that management is still dragging its feet and has not yet got around to giving me the money I asked for to do that security project — I'd be crucified for telling tales out of school, and for making myself look damned foolish.

Who can blame the manager for wanting to cover his own flanks?

## Don't Pass the Password

Additionally, managers have often contributed to the situation in advance with insufficient attention to their own security procedures. A password is very much like the numbers used to open a combination lock — except that no one can look over your shoulder as you try to open the door. Many managers fail to emphasise the extraordinary sensitivity and value of a password.

It's extremely difficult to penetrate a password-protected computer without specific knowledge of the password. Passwords often have eight positions, each of which can be one of 26 letters or ten digits. So the number of theoretical combinations is 36 to the eighth power, or more than 2,281,000,000,000. Clearly, it's not very likely that someone could make a correct guess. (But that's not impossible, either; I've got part-way through the log-on procedure of some computers by making educated guesses about likely passwords.)

Break-ins arise from one of two scenarios: either the computer's passwords have become semi-public knowledge — for example, passed around on computer bulletin boards — as a result of sloppiness; or the company has never changed the more or less standard password that comes with the computer when it arrives from the manufacturer.

The bottom line for business readers is this: it's not difficult to protect your company's data assets from unauthorised users. Guard the passwords as you would any other sensitive data; let users know that they are responsible for safeguarding their passwords, and therefore for password misuse. Enforce password security as you would check employee badges before admitting employees. Common sense will go a long way towards protecting you. □

*It's easy to overlook the terminal when you're thinking about buying a computer system; they all look much the same, and you might fall into the trap of thinking a terminal is just a screen to display your data. In fact, there are several different kinds of terminal, and it's important to know what you need from one when you're setting up the system.*

# TERMINALS

## Are you Dumb or Smart?

BY EVAN MCHUGH

**W**hether you are buying a terminal for yourself or for your staff you will find there are numerous aspects to consider; one manufacturer lists no less than 68 different features to take into account when deciding which terminal to buy!

Many of these features will be in conflict with one another, so you have to consider a number of trade-offs. The one thing you can't do — although many people, to their cost, have tried to — is take the purchase of a computer terminal lightly. Terminals often appear to be indistinguishable from one another, but the astute buyer should consider the functions he requires and compare several terminals offering them in order to get the best value for money and the best result in the workplace.

### Terminals and Computers

Some readers may not fully understand why terminals are needed, what they are for, or what the full range of options is. A terminal operates as an interface between the computer user and the computer. The user types instructions or answers, which the terminal translates and transmits to the computer. The computer responds and the terminal translates and presents its messages for the user.

That is the simple relationship; the form that relationship takes, however, is quite complex and varied. The way the terminal can transmit and translate information travelling in both directions will

affect the efficiency of both the user and the computer.

A terminal must be able to fully support all the functions of all the software packages which will be used on it. It must be able, under the control of the computer, to present its information in a comprehensible and attractive manner for the human being gazing into it. Conversely, the input from the person must be transmitted back to the machine quickly and correctly. It's most desirable if this can be achieved with minimal interference in the functions of the computer, and little or no obvious delay for the person using it.

This can be done in a number of ways. A good terminal can support much of the data transfer process through various features and functions. Some of the functions include cursor addressing, scrolling, buffering, and using protected fields, multiple pages and pixel addressing (on graphics terminals). Naturally, the quality, level and extent of a terminal's functions will be reflected in its cost. So you eventually hit the limiting factor that makes it necessary to be discerning in buying. Some of the more sophisticated terminals can cost over \$20,000 — which means it's not hard to do a lot of damage to even the healthiest budget, with very little trouble.

### Features

What the features of a specific terminal are depends on the purpose for which it has been designed. The most basic and

common use for terminals is in text handling; graphics and high-resolution imaging require more sophisticated machines.

Depending on your applications, a terminal may be required to have colour, high-resolution display, 'intelligence' and high-speed image generation, or high-speed data transfer from input port to screen. These are the variables crucial to the performance of the terminal.

Two more factors which might seem less important, but which should not be lightly dismissed, are ergonomics and styling. These are the 'trendy' features you may find slick advertising managers using to sell their terminals. However, the manager who doesn't take these aspects into account may be in for a few shocks.

### Choosing a Terminal

Taking as a starting point the dictum: "Buy the best you can afford", the question which follows is "how high do you go?" A lot of terminals are sold on the basis of their supposedly fabulous features. They tout reverse video, blank fields, protected fields, flashing fields, status lines and numerous emulations. But if the packages you use don't make use of those features, they aren't worth anything to you. Don't buy what you will never need. Try to match the product with the application.

Aspects such as ergonomics can often be considered after your initial specifications have been met. This is particularly

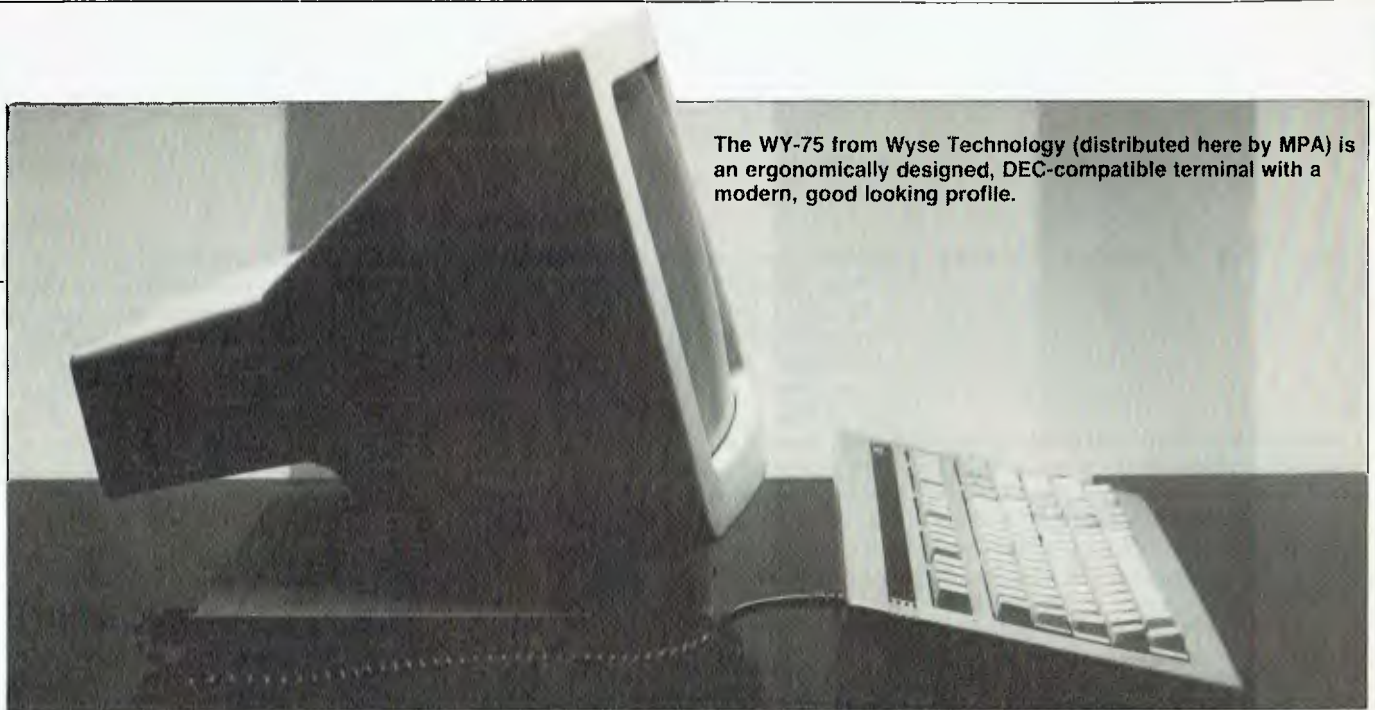

The WY-75 from Wyse Technology (distributed here by MPA) is an ergonomically designed, DEC-compatible terminal with a modern, good looking profile.

Terminal	Manufacturer	Text	Graphics	Colour	Ergonomics	Resolution	Function Keys	Price
WY-50	MPA	Yes	No	Green	Yes	7x13 matrix	16	\$695
KDS 62	Datron/QT	Yes	No	Green	Some	7x9 matrix	11	poa
VA120	Digital Source	Yes	No		Yes	7x9 matrix	none	poa
VA140	Digital Source	Yes	No		Yes	7x9 matrix	7	poa
TEK 4105	Tektronix	Yes	Yes	64	Yes	480 x 360	8/all but 4	poa
TEK 4107	Tektronix	Yes	Yes	64	Yes	640 x 480	8/all but 4	poa
TEK 4109	Tektronix	Yes	Yes	4096	Yes	640 x 480	8/all but 4	poa
GX-100	Minicomip	Yes	Yes	Green	Yes	768 x 585	16	poa
Ergo 201	Case Comms	Yes	Optional	Grn/Amb	Yes	7x11 matrix	16	poa
Ergo 301	Case Comms	Yes	Optional	Grn/Amb	Yes	7x11 matrix	4	poa
WY 300	MPA	Yes	No	8	Yes	800 x 327	8	\$1995
AWA 8602	AWA	Yes	Yes	8/grn/amb	Yes	512 x 384	24	\$3235, \$3837 with colour
VX 128	MPA	Yes	Yes	8	Some	672 x 480	No keybd	\$11,107
VX 384	MPA	Yes	Yes	16.8 Mill	Some	672 x 480	No keybd	\$14,210
Freedom 110	Moncrieff	Yes	No	Green	Yes	7x9 matrix	10	poa
Freedom 200	Moncrieff	Yes	No	Grn/amb	Yes	7x9 matrix	10	poa
Freedom 220	Moncrieff	Yes	No	Green	Yes	7x9 matrix	10	poa
Visual 50	Kenelec	Yes	No		Yes	7x11 matrix	No	\$1092
Visual 550	Kenelec	Yes	Yes		Yes	768 x 585	12	\$3420

Table 1. Terminal specifications supplied by companies responding to our requests for information. It isn't possible to list all details of all terminals, and some of the details are somewhat bald, but they will give you indications of the capabilities of the terminals. Information on any of the terminals listed can be obtained by writing to or calling the relevant companies. In some cases only a few terminals have been chosen from a company's range to indicate the basic features of all the range. The prices for many of these terminals fluctuate considerably with exchange rates and in these cases you will be able to get the price on application to the company.

the case with terminals made in large volumes at your request and to your specifications. In this case you can, for example, ask for a keyboard suitable to your needs and pocket.

In the case of smaller volumes or off-the-shelf purchases, there are various models which have interchangeable parts or upgrade paths that could match your

needs. The only way to find out is by thoroughly researching what is available from your potential supplier. You may also need to do a bit of arm-twisting to get what you want, but you're the one with the cash and if the nice salesman wants to get your custom he should give you whatever you are prepared to pay for.

## Colour

Colour is a feature which many people will consider a luxury; for many it's a luxury they can't afford. Colour adds around \$400 to the cost of a terminal. Colour capability is also a tiger with many different stripes. Basic colour terminals will give you a choice of about eight or sixteen colours. For display purposes, for example to make a screen attractive or highlight important information, that should be sufficient.

If, however, you are looking for a terminal with a broader spectrum of colours – say for generating computer images – there are terminals which offer 5000 colours or more. At *Your Computer* the greatest colour capability we've seen on

a terminal was on a professional system capable of generating eight million colours – although not all could be displayed on the screen at once. The total number of colours the terminal could display at any one time was a palette of 64.

Some terminals are described by their manufacturer or distributor as providing 256 colours. In some cases these are not 256 distinct colours, but rather 16 actual colours, each of which can be specified in terms of 16 luminances to give 16 shades of each colour – hence the total of 256. If you want more than 16 distinct colours, you're probably looking at a more expensive terminal.

If your application requires only text handling capability, you may find the need for colour is not great. In our experience colour often requires higher resolutions or better-quality screens than do monochrome displays, in order to retain the clarity of the image. Characters are harder to get in focus on a colour screen and can be susceptible to an annoying flicker.

If you decide on a mono display there may be a choice between white on black, green on dark green, or amber on brown. The latter is claimed to be the best colour for keeping eyestrain to a minimum, and has become the standard

monochrome screen combination in Europe. When I have the choice, amber is the one I go for; it only takes a few minutes to get used to, and then it's very comfortable to look at. A scientific reason given for amber being easy on the eyes is that yellow is the only colour which doesn't produce an image of its complementary colour on the retina, which apparently makes looking at shades of yellow less taxing on the eyes, and so results in fewer complaints of eyestrain from operators.

### Resolution

As has been mentioned in discussing colour monitors and text display, image resolution will play a great part in determining which terminal you choose. In a display of text it should be impossible to see the gaps between the dots in the matrix that forms each character. A good text screen can have around 250 by 190 resolution, which will display text in 80 columns by 25 rows. *On no account should the display flicker or wobble.*

Graphics screens tend to need significantly higher resolutions in order to present detail adequately.

One method used on graphics display terminals to show more detail is to make the screen larger so more dots can be displayed. Clearly, though, there are limits

to how large the screen can be.

The hardware required to drive a very large screen is expensive, as it must be able to drive the scanning beam quickly enough to prevent flickering. If the terminal uses colour as well, the problem is even worse. The consequences of this are that such screens are only used for highly specialised applications and cost incredible amounts – tens of thousands of dollars.

Another method used to get around those high screen rates is vector scanning. Vector graphics terminals display 'wire frame' graphics, in which only the lines of an image are drawn (none of it is 'filled in'). The name 'vector graphics' refers to the technique of driving the electron beam only along the paths required to draw lines, rather than continually scanning the screen as in the more usual 'raster' graphics.

Raster scanning involves scanning every row of the screen, and flashing on and off where an image is required. The vector technique means that simple images, or those requiring graphics lines that go in all sorts of directions, can be drawn more quickly than using a raster scan. If you don't require solid images, but tend to use complex outline drawings, a vector scanning terminal may be the answer.



The Visual 50 from Visual Technology, distributed by Kenelec.



Case Communications' Ergo 201 ergonomic terminal.

### Dumb vs Smart

There is no such thing as an 'intelligent' terminal. The expression was thought up by marketing people to describe, or confuse the consumer over, the expanded features of some terminals.

There is no term to distinguish one group of terminals as more intelligent than another. It may be more appropriate to rate them on a sliding scale, an IQ level if you like. At the lowest levels are terminals which are little more than teletype displays, taking whatever is typed at the keyboard and transmitting it to the host computer. Whatever they receive is displayed on the screen, line by line.

At the highest level terminals can take an entire screen, which is transmitted to the terminal by the host computer, display it with protected fields, highlighted fields and input fields, allow all the input fields to be dynamically edited, and then transmit the entire screen, or selected parts, back to the computer.

An example which shows the importance of this difference is a word processing package. Whenever you type a character, the terminal has to send it to the host computer and then get the character back to its correct position on the screen. With a package like Wordstar you have protected fields at the top of the screen which mustn't get text written over them when the screen scrolls up. Consequently, you can't get away with a dumb terminal for using Wordstar. Your terminal has to be intelligent enough to support this sort of demand.

If the computer itself was able to drive the screen, it probably could produce the desired effects even on a dumb terminal. But it would not have time to do very much else.



The Modgraph displays some impressive graphics.

Two other attributes of more 'intelligent' terminals are that you can configure them to emulate different terminals, and you can program their function keys, if they have them, to support different packages.

Different terminals send their signals through different paths, or use different techniques for handshaking (communicating with the computer). Typical terminal protocols are ADM3A, VT100 and Televideo. If a terminal can emulate a certain protocol, it can be connected and used with computers that communicate using that protocol.

Programmable function keys are a means of making operation of software packages a little easier. If, to initiate a function, you have to type a number of instructions, you may find it easier to program the functions into a function key; so when you require that function, you just press that one key to execute all the commands. An example of this is in word processing, where a control sequence will toggle the 'insert text' mode. On some dedicated word processing terminals a function key does this, masking the control sequence from the user at all times.

You should be aware that there are actually two types of function keys: *programmable* function keys and *program* function keys. While they sound similar, those few letters' variation should alert the astute terminal buyer to suspect a subtle yet significant difference. The programmable function keys can be configured to send any sequence, while program function keys send a particular sequence only. This means the program function key signal must be understood by the program in use in order to work properly. For example, a program function key may only be able to send a Control-C, while a programmable function key could be set up to send a Control-C or a CLOSE ALL FILES command, or any other desired sequence.

At the very peak of terminal performance you will find personal computers acting as terminals. In many cases they will be part of a distributed processing solution to an organisation's ADP needs, and operate as workstations. The sophistication and usage of such configurations will evolve with the system of which they are a part, but will usually revolve around simple terminal emulation and file transfer software. Computers with particular emphasis in this area are the IBM-PC, with its support from larger IBM systems, the Cromemco C-10 and Morrow MD-11.

### Ergonomics

The final issue to consider when looking at a terminal is ergonomics. Many government departments and large businesses (banks in particular) are reporting increasing cases of computer-related compensation claims. The most common claims have been for eye- and hand-related problems.

**Table 2. Addresses are for head offices only; many firms operate offices in other states. Contact the firm or check the phone book for details.**

Microprocessor Applications (MPA), 48 Rutland Road, Box Hill 3128.
Datron, 79-81 Regent Street, Redfern 2016.
Q.T Computer Systems, 140A Victoria Road, Gladesville 2111.
Digital Source, 169 Phillip Street, Waterloo 2017.
Tektronix, 80 Waterloo Road, North Ryde 2113.
Minicomp, 378 Forest Road, Hurstville 2220.
Case Communications, 1-3 Rodborough Road, Frenchs Forest 2086.
AWA, Data Terminal Group, Engineering Products Division, 422 Lane Cove Road, North Ryde 2113.
Moncrieff, 176 Wittenoom Street, East Perth 6000.
Kenelec, 48 Henderson Road, Clayton 3168.



Above: The AWA 8602 colour computer terminal.



Tektronix's TEK 4109 computer display terminal has an addressable display matrix of 4096 by 4096, which allows the user to zoom in on a portion of the display.

Introduction of computer equipment is often preceded by numerous union claims for more money and adequate medical surveillance to protect staff. One of the ways to protect yourself is to install equipment that is comfortable to use and which does not cause unnecessary strain for users.

Ergonomics refers to the relationship between equipment and people. It looks at the type of work the person is required to do and the creation of the best environment for doing it. Consequently, the complete ergonomic requirement for a computer environment covers air temperature, light levels, humidity, seats, desks, stands and terminals.

Although the environmental needs of an office are often not given the consideration they should receive, the terminal is critical to data entry and should be given special attention. The two main concerns are the keyboard and the screen.

Ideally, keyboards should be detachable, have a concave profile on keys, have key centres about 19 mm apart, and have keys with a smooth action.

Detachable keyboards let the user move the keyboard to the position in which he or she finds it most comfortable to operate. The dished profile (where the rows of keys are curved downwards) means fingers do not have to travel so far to strike the upper and lower rows of keys as on the usual straight-line layout. The same applies with key size; if the gap between keys is too big fingers will have to stretch to get to some keys.

Smooth key action is important. The current rise in cases of tenosynovitis may be contributed to by the fact that some keyboards increase the strain on the tendons of the wrist and arm by forcing them to work even harder to cope with the keyboard's bad action. Constant repetitive movement of the fingers is hard enough on the tendons, without the equipment making matters worse.

When considering screens, the major factors to look at are adjustability, colour (which we have already discussed above), screen refresh rates and resolution.

It is important that the user be looking directly at the screen, not from an angle. It is therefore an advantage if the screen can be both tilted and swivelled to suit everyone who operates it. The reason

**Below:** The Freedom 200 from Liberty Electronics, distributed by Moncrieff in Australia, has 106 sculptured keys clustered in functional groups.

**Right:** The Tatung TVT-6600 displays its tilt and swivel facilities.

you need to get the screen on the right angle is so your eye moves across each line in a continuous sideways movement. If the screen is on an angle you constantly move your eye across by a small increment and then up or down by a small increment. This will result in strain on the muscles controlling the movement of your eye.

Flicker is the result of slow refresh rates when scanning screens. You will notice it in cheap monitors as jittery characters or bands of darkness that scroll up the screen. Flicker and wobble are just about the worst problems a terminal can have, and any user would be justified in refusing to work on such a piece of equipment. The effect is that the eye has to focus on a moving target, and

it is both tiring and slows down work. The screen display *must be steady*.

Resolution, which we mentioned before, should be good enough so the eye, and brain, do not have to work overtime extrapolating the character that appears on the screen.

One thing that should be said at the end of all this theory is there are a lot of terminals which conform to none of the supposedly necessary ideal features, but which give their users no problems at all. A case in point is Jane Mackenzie, *Your Computer's* editor, who uses a terminal (which shall remain nameless) that Matt Whelan and I pour abuse on and continuously threaten to take out and bury in concrete. Jane loves it and glares threateningly whenever we suggest it



may be time to upgrade. It's old, the screen is dim, and the keyboard is attached, sits high off the desk, has nowhere for you to rest your hands and has no function keys. It only just supports Wordstar functions. Jane uses it about 40 per cent of the time she is in the office and has no trouble with it at all.

The lesson to be learned from this is obviously that whatever feels comfortable is what you should use. If it feels good and does what you want, buy it — but don't force it on other users who may be more discerning, or less worried about your company's finances than you are!

All the normal traps for innocent buyers are present in the terminal market, but if you apply the standard procedure for buying any computer product you should not come off too badly. Define your needs, shop around for terminals that best match those needs, see demonstrations of the most promising terminals, get in touch with owners of terminals you are considering, to get their opinions, and finally, negotiate a contract with the supplier that is the best combination of functions, reliability, usability, support and price.

If you want more information on the terminals mentioned in the table accompanying this article, the addresses of the companies that assisted us by supplying information on their products are listed in Table 2. □

# Introducing the VISUAL 1050 Personal Computer



**The complete professional solution at an unbeatable price.**

The VISUAL 1050 is a versatile personal computer designed to help you manage words, numbers and graphics. You get top-rated software, ready to run on hardware which offers the features and quality you should demand.

It's an unbeatable value. The VISUAL 1050 solves more professional problems than any other computer in its class. And it's yours complete for only \$2995.\*

Come in for a free demonstration. The easy-to-use VISUAL 1050.

	VISUAL 1050	IBM™ PC	APPLE™ IIe	DEC RAINBOW™
Serial Port	Standard	Option	Option	Standard
Parallel Port	Standard	Option	Option	Standard
Bit-Mapped Graphics	Standard	Option	Standard	Option
Word Processing Software	Standard	Option	Option	Option
Spreadsheet Software	Standard	Option	Option	Option
Business Graphics Software	Standard	Option	Option	Option
Communications Software	Standard	Option	Option	Option
Dual Drive Capacity	800KB	640KB	280KB	800KB
Graphics Resolution	640 x 300	640 x 200	280 x 192	800 x 240
Keys on Keyboard	93	83	63	105
Standard Memory	128K	64K	64K	64K
Optional Winchester	Yes	Yes	Yes	Yes
Tilt & Swivel Display	Yes	No	No	No
Fill in prices and Compare	\$2995	\$	\$	\$

**KENELEC (AUST.) PTY. LTD.** 48 Henderson Road,  
Clayton, Vic. 560 1011  
(INCORPORATED IN VICTORIA)

NSW (02) 439 5500. Q'LAND (07) 393 0909. SA (08) 42 6877. WA (09) 322 4542

## DISTRIBUTORS

**QUEENSLAND:** Ipswich Sigmatech (07) 202 4121; **Mayne** Competron (07) 52 9700; **Underwood** Computer Connections (07) 341 3466; **Townsville** Computer Tutor (077) 75 4000; **WESTERN AUSTRALIA:** Cannington Australasian Computer Enterprises (09) 451 7304.

\*Plus 20% Sales Tax.

While Lotus 1-2-3 has grabbed the limelight in the last year, many readers will remember another integrated software package that appeared around the same time, but was overcome in the subsequent Lotusmania. However, it is fighting back in a new form.

BY LES BELL

# Corporate MBA

**A**round the same time as Lotus 1-2-3 appeared on the market, or even before, a new company called Context Management Systems started advertising a new program called MBA. The new package could perform spreadsheet calculations, graphics, word processing, simple database functions and communications — all in one program.

It really could. The comms functions were a little late in arriving, but otherwise the product performed as advertised. There were just a couple of little gotchas.

Because Context MBA was written in Pascal for the UCSD p-system, it acquired the major deficiency of that system: a certain lack of speed. In short, once spreadsheets started getting up to the size where MBA users would normally function, it slowed dramatically. Some users found this unacceptable.

And second, because it ran (runs) under the UCSD p-system operating system, it could not access files created under PC DOS. These two drawbacks, coupled with a media blitz for Lotus, turned buyers away.

Funnily enough, Context was (is) also available for the HP Model 200 desktop, which is 68000-based, and the difference in performance was staggering, so quite possibly the product has done well in that particular market.

One year on, a new, improved, sleeker MBA is available. Launched under the new name of Corporate MBA, the package overcomes the major problems of its progenitor.

There's something in all of us which reacts to constant exposure of products: if I hear another word about 'Bodyline' I'll scream. Since Lotus has become the Torvil and Dean of the software world, people seem to be willing to look at alternatives.

Corporate MBA has a wider range of functions than most integrated software packages. Obviously, it has a spreadsheet function, closely modelled on Visicalc, though with many major enhancements. Spreadsheet data can be graphed by inserting a graph formula into a spreadsheet cell.

The MBA database feature allows the user to retrieve selected records, sort, eliminate duplicates and generally manipulate the spreadsheet as a database. Database formats and data can be stored separately, permitting several ways to view the database. In addition, screen forms can be created for invoices, mailing labels, purchase orders and the like.

Each cell can be used to store text: up to three pages of it, in fact. Format rulers can be set up to set margins, paragraph-

ing and other print formats. Best of all, spreadsheet cells can be copied into text, so reports become simple to keep up to date. When printing, text cells can be alternated with graphs or spreadsheet models.

Context MBA boasts two kinds of communications capability: standard asynchronous communications allows access to remote computers, timeshare systems and other PCs; while with the addition of an IRMA board, MBA provides emulation of the IBM 3278 terminal for communication with Big Blue (and compatible) mainframes.

## Spreadsheet Capabilities

As a spreadsheet, Corporate MBA is not half bad. It has all the usual spreadsheet functions, plus quite a few of the less usual ones.

For example, as well as the Internal Rate of Return of a discounted cash flow, MBA boasts the Modified Internal Rate of Return, which assumes re-investment of positive cashflows at a different rate from the discount rate.

Control functions include the choose function (@CHZ(formula,range)) which chooses the value offset by the given formula from the start of the range, and the lookup function (@LOK(formula,range)), which works in the same way as

Figure 1. List of Corporate MBA spreadsheet commands.

B lank	Erase contents of specified cells [Marker, Box], Form, Ruler
C ommunications	Initiate telecommunications session with remote computer
D elete	Workspace rows or columns, Boxes, Markers, Forms, Rulers
E dit	Text or formula in current cell, Form, Ruler
F ormat	Specify row height; column width; numeric type for cells
G lobal	Specify Format for entire workspace; recalculation order
I nsert	New rows or cols into workspace; creat Marker, Box
K [Combine]	A number of cells into a single cell
M ove	Cells, rows, or columns to new location in workspace
N ew	Clears workspace -- erases entire contents
P rint	Contents of cells, or screen to attached printer
Q uit	Leave MBA and return to MS-DOS system
R eplicate	Copy cell contents--data or formulas--elsewhere in workspace
S torage	Store, load workspace; execute @CPY's; database commands; data exchange; set default Prefix
T itle	Fix row, col title edges at and to above left of current cell
V iew	Names of volumes, markers, etc.; Formulas or results of formulas
W indow	Create, synchronise, merge 2-4 windows; use Forms, plot Graphs
X {Expand}	A cell into a range of cells; as either Text or Numbers
!	Recalculate specified formulas in the workspace

its counterpart in other spreadsheets.

New in MBA is the @CPY ([drive:] document, M1...M2) function, which specifies a range in the specified document (between markers M1 and M2) which will be copied into the current spreadsheet using the /SC command. This is a particularly powerful feature for consolidation work.

MBA commands are a superset of those in Visicalc, but most of them are considerably longer and there are more of them. Hitting the / key brings up a prompt line:

```
/: Blk Com Del Ed Frmt Gbl Ins Komb
Mov New Prnt Q Repl Stor Ttl V Wnd
Xpnd !
```

The use of mnemonics, instead of just initial letters, is very helpful. However, at this point one can simply hit the question mark (?) key to receive a screen full of help. Many of the options have doubtless suggested themselves to you from the above list, but for the sake of completeness, they are all explained in Figure 1.

The help scheme naturally continues to operate as one works further and further down the menu system. For example, after you type /B?, the screen explains the various options for blanking individual cells, rows, columns, a range, a form, a word processing ruler or the entire workspace.

In order to deal with subsections of the entire workspace, which can contain as many as 95,000 cells, MBA allows the user to create markers, which are named cells, and boxes, which are named ranges of cells. Thus you don't have to remember what range of cells contains the bottom line of your forecast, but can simply refer to it by name.

An interesting feature of MBA is its virtual memory capability. While most spreadsheets claim vast spreadsheet sizes, most (if not all) are limited by the available memory in the PC. Even a fully stuffed PC could not access the full spreadsheet size of most programs.

MBA is different. If your spreadsheet exceeds the size of available memory, the program will swap part of it out to disk and keep going. Most activity takes place in a limited area at one time, and since the area on disk is not accessed, no speed problems will arise. This is particularly true with MBA, since one area of the spreadsheet may be a financial model, another will contain a database, another may contain contoms cells and another

may be word-processed reports, and only one of these will be active at any time.

To further support this concept of only working with one part of a spreadsheet, MBA supports a limited recalculation feature, so that no time is lost through recalculating an entire massive sheet.

The /SA command accesses the database storage commands, which are broadly similar in scope to those of Lotus 1-2-3. Rather than a database, I would term it a list manager, but there's no doubt an experienced user can do some amazing things with it when it is coupled with the spreadsheet concept.

Once a database has been selected for access, the user can set up a selection criterion in a cell, and then read in the records that meet the criterion. The database subset which is now in the workspace can be sorted, indexed, duplicates removed, and generally updated.

Once a database is in the spreadsheet, all commands are quite fast, since no disk accesses are involved.

Associated with the database functions are the forms facilities. These commands allow the user to design screen forms for data entry into the database. Fields can be defined at arbitrary locations on the screen, together with prompts, and forms can even be used for print formatting to produce invoices, custom reports and so on.

### Word Processing

Realising that people who work with numbers also work with words, Context has included a fairly comprehensive word processor in MBA.

It incorporates all the most frequently used commands from standard word processors, including text insertion, text deletion, reformatting and global search and replace. Block movement is possible as a two-step process: first save the block to the Savespace (a buffer), then move to the target location and recall the Savespace.

Deleted text also goes into a buffer, allowing its subsequent 'undeletion'.

Text formats are stored in ruler lines, independent of word processing cells, so a common format can be used for several documents. These let the user set up various defaults such as number of lines per page, whether word wrapping is on, and so on. Multiple rulers can be used in one document.

The word processor itself works on

modes: that is, it starts up in command mode, when typing I put it into Insert mode, and so on. I personally find this style of word processor a bit tedious to use, since I can never recall what mode I'm in, but it seems to work well for occasional users - and this is exactly the audience for MBA's word processor.

Although it is simple to use, the word processor is quite powerful. The ability to insert control sequences into the text allows the user to take advantage of special features of the printer, such as expanded type or underlining.

The entire text (up to three pages) fits into a single cell, while intuitively one might expect it to take up many. That's just the way MBA works, and it is reflected in the way spreadsheets are copied into reports, for example.

Rather than copying an area of the main spreadsheet directly into the document, the range of cells must first be combined into one cell using the /K command, then that can be brought into the word processor using the Copy command.

### Macro Facility

Like its major opposition, MBA now has a macro facility which allows the user to effectively program the spreadsheet. In a style reminiscent of dBase, MBA macro commands start with an ampersand (&).

Creating a macro command sequence is quite simple: just press F8 and then use the normal keystroke sequence to solve a problem. All commands will be stored in the macro until F8 is pressed again. Once the macro is stored in a cell, pressing F7 will recall it and execute it.

Macro commands are available for cursor movement, editing, displaying messages and accepting input. An IF.. THEN.. ELSE statement is available for simple control of 'program' flow.

Once a macro has been developed, it can be distributed to allow anybody to set up a model. With the marker name STARTUP inserted in a macro cell, when the spreadsheet is loaded, the macro will be automatically executed.

### Communications

MBA supports two kinds of communications. The first is standard asynchronous communications which is used, via dial-up lines, to access electronic mail services and databases. Most of the options MBA provides are unfortunately for 'smart' modems such as the Hayes, which unfortunately aren't permitted here.

However, if we had them, MBA would allow us to automatically dial into a bureau service, log in and start a task, all without human intervention. This is all done by the /C command which picks up the various parameters it needs from a communications formula stored in a cell somewhere. This formula specifies the baud rate and so on, where to save incoming text and other options.

MBA is quite smart at pulling apart tabular data, such as stock exchange listings, and inserting it into spreadsheet cells for subsequent calculations.

The other kind of comms supported by MBA is IBM 3270 emulation. This is used generally within a company to link to a central mainframe computer. In order to do this, an IRMA board must be plugged into the PC to provide the appropriate hardware interface to the mainframe cluster controller.

With the addition of the IRMA board, MBA can turn the IBM-PC into an IBM 3278 terminal, allowing access to mainframe programs and systems.

### Import/Export

MBA is very well fitted out in the import/export department. It can import and export files with dBase II, Software Arts DIF format, MBA Interchange Format (MIF), text files, and word processing files, and can also import directly from Multiplan and Visicalc.

This is a marvellous feature for those trading up from one of these programs, and also makes MBA integrate particularly well with other products. For example, an executive can 'rough out' a memo using MBA's word processing, then transfer it to his secretary to be finished off and printed using WordStar. Or sales figures could be captured from a dBase inventory system and transferred straight into MBA for comparison with forecast.

### Operation

MBA is very simple to run. After booting PC DOS, just insert the disk MBA1 and type MBA. The bulk of the program is read from this disk, and it then prompts for disk MBA2 which should be left in the drive while the system runs.

The system can be installed on a hard disk quite easily and with minimum aggravation.

The documentation supplied with MBA is excellent. The main manual, which comes in a slip case a little bigger than the IBM standard, is split into two



### SOFTWARE REPORT CARD

Program:	Corporate MBA			
Made by:	Context			
Useful for:	Numerate management			
Hardware required:	IBM-PC, 320 Kbytes RAM, one disk drive			
<b>Ratings:</b>	<b>Excellent</b>	<b>Good</b>	<b>Well, maybe</b>	<b>Poor</b>
Documentation:	•			
Ease of use:	•			
Speed:		•		
Functionality:	•			
Support:	•			
Value for money:	•			
Price:	\$850 rrp			
Review package from:	Intelligence Australia, 4th Floor, 204 Clarence St, Sydney 2000. (02) 267-1711.			

parts, a comprehensive tutorial and the reference manual. Both are excellent for their purposes.

The examples for the tutorial are supplied on a demonstration diskette, but if the user does not want to use the written tutorial there is an alternative disk-based tutorial which takes about three hours to complete. This is, in fact, written as a series of MBA macros!

Also supplied with the documentation is a Desktop Reference guide, which is designed to stand up to a pounding among other papers. This uses block diagrams to illustrate the menu selections, so that a user can find his way around the system.

There's also a booklet on using Corporate MBA on the IBM-PC, one on using the Disk Tutorial, and the other miscellany that comes with most software packages - such as the 'Context 500 Support Program' and so on. There's also a template for the PC function keys.

A first-time user should have only minimal trouble after getting through that little lot.

### Summation

All in all, then, the new improved Corporate MBA is quite different to its predecessor. It's faster, runs under PC DOS, and offers considerably higher functionality. In many respects, it's on the same level as Lotus 1-2-3, although it has many functions that that program has not: word processing and communications, for example, although the new Lotus package, Symphony, does include these extra applications.

It is well put together, with a logical design which assists the new user in getting over the multiplicity of functions and commands. The level of integration is very high, with the ability to transfer data from communications sessions to the spreadsheet, for example.

Whether Corporate MBA will gain enough support to compete successfully against Lotus, we shall just have to wait and see. However, it is an interesting alternative, and I would counsel against buying 1-2-3 (or any other spreadsheet) without examining Corporate MBA first. □

# Organised Auditors

BY NORMAN KEMP



**F**or a group of experienced computer professionals whose job is to probe into intricate accountancy software on large mainframes, an Apple IIe may seem like a toy and beneath their consideration. But it was the homely Apple that was at the centre of a recent Australian EDP Auditors' Association convention in Sydney, and which capably handled all the conference planning and organisation, including room reservations for visiting delegates.

Auditors are frequently highly qualified chartered accountants with a specialised knowledge of the computer programs used not only by large financial institutions such as banks and insurance companies, but also in almost every area of government and scores of medium-sized businesses. White-collar computer crime is a serious topic these days, and one of the main tasks of EDP auditors is to search through computer software,

checking audit trails which lead to financial dealings over a period of months or years, and searching for irregularities which may lead to the exposure of a deliberate fraud or reveal inefficiency or incompetence on the part of a company's programmers or advisers.

Auditors are familiar with the details of the big-name commercial accountancy packages, and are trained to look deeply into custom-tailored applications devised by in-house programmers or contract firms. Not only software but also documentation is examined for its thoroughness and assistance in providing quick and accurate information on the various aspects of a company or government department. Patience, and a nose for the unusual, are two of the characteristics of a professional EDP auditor.

## Suspicious Minds

Following up suspicious leads and tracking down criminals suggest a glamorous

occupation, but auditing also involves much tedious and routine investigation of accounting systems, checking on their effectiveness and looking for technical ways to improve them. Although this is obviously geared to increasing the efficiency of auditing processes, there is also a considerable spin-off to organisations in having their systems upgraded and any weaknesses pointed out before damage can be done or an employee can take advantage of inside knowledge to interfere illicitly with the programs.

Not every attempt to gain access to a computer system has an overtly criminal intent; an auditor can also detect when an employee is using the firm's computer for a spare-time activity, which frequently involves operating another business on the side. Although technically such unauthorised activity is theft of company property – the firm is presumably paying for the computer time involved – prosecutions in these instances are rare; employees are usually warned off or, if there is sufficient aggravation, fired. Auditors have discovered instances such as restaurant operating or book-making tucked away among the legitimate activities of a financial system, and indeed may find more of these than the more widely-publicised 'computer theft' involving the stripping off of hundreds of thousands of dollars through manipulation of customer accounts or invention of fake records, such as insurance claims to be paid on spurious policies.

When auditors meet, their talk is often serious and highly technical, which is not surprising when the roll call of the Sixth National Conference of the EDP Auditors' Association is considered. Delegates included systems designers, internal and management auditors, external auditors, educationalists, government audit and administrative personnel, information systems consultants, and company line management with EDP responsibilities such as Management Information Services (MIS) and office automation. All would have prestigious degrees or diplomas in university subjects including accounting or computer sciences, or equivalent qualifications in other spheres.

Their fields of activity cover not only security and controls on large mainframe computers, but also general applications such as implementing microcomputers to

*It had never occurred to the Association of EDP Auditors to use a microcomputer to organise its affairs, despite the fact that its members work daily with computers. When Apple presented a IIe Business System to the Association, its first task was to organise the annual national conference.*

mainframes without upsetting the DP department, wrecking the company database or duplicating information that is already available on files. They may also advise on the administration of accounting services and facilities without wasting company manpower or other resources; and analyse in-house programs with recommendations for updates or alterations to meet changing circumstances, or following the departure of key staff.

Of the 800 members who belong to the Australian association — there are about 8000 worldwide — nearly 300 attended the Sydney conference, according to secretary Garry Dinnie who works for Sydney chartered accounts Arthur Young and Co. For the first time in the association's history the organisation of this mixed assembly was handled entirely by a computer, namely an Apple IIe Business System donated by Apple Computer Australia to the New South Wales Chapter.

"Previously all the work of conference organising had been centred around a bureau, with the directors of the association putting in a lot of voluntary effort," said Dinnie. "This year, we had only about six weeks to prepare everything from the time the computer was delivered, but we managed it, including the writing of special software programs to facilitate the conference organisation."

#### **dBase Efficiency**

The system presented by Apple, which was sponsor to the conference, comprised an Apple IIe with two 140K disk drives and a dot matrix printer. A Chapter member, David Patch, who is an accountant with Touche, Ross and Co, took on the task of bringing the system up from scratch to working efficiency using dBase II.

The first job was the collation of the conference mailing and attendance lists, which in turn were matched with the estimated attendance at sessions of each member, length of stay in Sydney and the amount which would be paid or owed in fees. A conference registration list was compiled, and to this was added the requirements of delegates in accommodation and reservations. A refinement added to the program enabled the organisers to keep track of delegates who

had taken advantage of a discount scheme and paid an 'early bird' registration fee.

"Having got the conference over, the chapter can now consider what other jobs the computer can do," Garry Dinnie said. A part-time secretary, Helen Gulson, has been appointed to look after NSW and Canberra memberships, and to place on the computer the records which were previously kept manually. Among these will be a general ledger and up-to-date list of fees collected and owing — a system that will work rather more quickly and smoothly than before and save the organisation some of the chore of following up late dues.

Word processing will be added soon, using the Australian-designed Zardax system. A courteous touch is the proposal to send new members a letter of welcome to the chapter, which will be on the word processing file.

"Although most of our members work professionally with computers, it just had not occurred to anyone to think about a small system for our own association's use," Garry Dinnie said. "But the Apple put up a most impressive performance in assisting us with the conference, and it will be an asset in keeping our running costs down within the chapter. Some of our members are conservative and have had doubts about micro computers, but it is capabilities such as these that can change even the most rigid attitudes."

ally with computers, it just had not occurred to anyone to think about a small system for our own association's use," Garry Dinnie said. "But the Apple put up a most impressive performance in assisting us with the conference, and it will be an asset in keeping our running costs down within the chapter. Some of our members are conservative and have had doubts about micro computers, but it is capabilities such as these that can change even the most rigid attitudes."



Word processing will be added soon, using the Australian-designed Zardax system. A courteous touch is the proposal to send new members a letter of welcome to the chapter, which will be on the word processing file.

"Although most of our members work professionally with computers, it just had not occurred to anyone to think about a small system for our own association's use," Garry Dinnie said. "But the Apple put up a most impressive performance in assisting us with the conference, and it will be an asset in keeping our running costs down within the chapter. Some of our members are conservative and have had doubts about micro computers, but it is capabilities such as these that can change even the most rigid attitudes."



# IF YOU CAN'T GET AN IBM PC, SETTLE FOR SOMETHING BETTER.

Once you discover the performance and the power of the Corona PC's,™ you'll quickly see the difference in today's standard for micro computing in the IBM-compatible world. Because the Corona PC's go beyond the standard to give you much more of what you're looking for in an IBM-compatible PC.

- Powerful, low-cost desktop and portable computers.
- 16-bit, fully compatible with IBM PC standard.
- Crisper, cleaner display and higher resolution graphics (640x325 pixels).
- 256K byte memory, room for 512K bytes on main board.
- Fast-access 360K byte floppy, communication and printer ports and 4 expansion slots are included.
- RAM-disk software.
- Includes MS-DOS<sup>1</sup>, GW BASIC<sup>2</sup>, PC Tutor<sup>3</sup>, and MultiMate<sup>4</sup> professional word processing system.
- Optional hard disk.
- Fully supported direct by AWA.



Corona PC's are available through AWA's continually expanding dealer network. For further information, ring AWA, or clip the coupon.

NSW (02) 922 3300    ACT (062) 47 7522  
 VIC (03) 529 4133    QLD (07) 369 3577  
 WA (09) 321 9334    TAS (002) 34 4532  
 SA (08) 79 9581    Auckland 76 0129

## AWA COMPUTERS

To: Corona PC Co-ordinator, AWA Computers,  
 132 Arthur St, North Sydney, N.S.W. 2060  
 Yes! Please send me more information on the powerful Corona PC.  
 Name: .....  
 Position: .....  
 Company: .....  
 Address: .....  
 City: ..... Postcode: ..... Tel: .....

AWA Computers Division. Amalgamated Wireless (Australasia) Limited Incorporated in N.S.W.  
 IBM is a registered TM of International Business Machines. 1. TM Microsoft 2. TM Microdata 3. TM Comprehensive Software Support. 4. TM Multimate International

If you want to get into data communications, you're going to need a modem — the 'black box' that converts digital data signals from the computer into signals that can be transmitted down the phone lines. In this article Evan McHugh discusses the ins and outs of modem technology.

# Call me

# Modem

'WHAT! More expense,' you say to yourself as you phone your bank manager and prepare for another trip to the computer store. Modems will cost you a fair slug, but, depending (oh yes, there is always a condition) on your needs, they will hurt your pocket less than many other peripherals such as printers and disk drives. You can get into modems for as little as \$150, which will give you quite a good modem for your money. The price can go as high as several thousand dollars for a full-featured, highly sophisticated modem.

Modems are essentially a means of connecting two computers that are too far apart for connection using a normal data cable. A modem converts data signals from a computer into audible signals, which can be transmitted down a normal phone line. To send data by any other means tends to be far more complex and expensive than this particularly simple solution. Obviously, for real data 'communications' you actually need two modems; one at each end of the exchange, to modulate and demodulate data (convert it from a digital signal to sound and back).

The exact origin of the word modem is not clear, but one suggestion from a Sybex Computer Books publication, *The RS-232 Solution*, by Joe Campbell goes like this:

"It is generally claimed that the word 'modem' is a portmanteau word derived from the technical terms MODulation (the process of converting

bits into tones) and DEModulation (the process of converting the tones back to bits). In fact, the term may be a corruption of the name of the Gaelic warrior hero, Mordem, who reportedly used lions to send code during battle. As reported by the eighteenth century historian James Macpherson, lions with distinctive roars were chosen in pairs. Code was generated by pulling the appropriate lion's tail, one tail for dots and the other for dashes. It is conjectured that the success of this practice explains the great number of lions found on heraldic coats of arms. At

any rate, the parallel between this ancient practice and modem technology is, you must agree, uncanny." (p 141)

### How Modems work

Modems are about the simplest of peripherals, in terms of the circuitry involved and what they actually do. Essentially, they take a digital input and convert it to a sound, using an audio tone generator. Two tone generators are required: one to signal a zero, the other to signal a one. Then the signals are just sent down a normal phone line with a computer





# Make one stop:

# COMPUTERSTOP™

## IN THIS CORNER, THE ONE AND ONLY CHALLENGER

The IBM PC compatible that competes with the IBM ... on price, on performance, on features, and on expandability. The Challenger is the computer for the small to medium size business. But it's more than that: because it is compatible with IBM PC software and hardware, it makes a superb scientific or industrial computer ... or even an IBM terminal. Monitor shown is optional.

Includes Software worth over \$800.

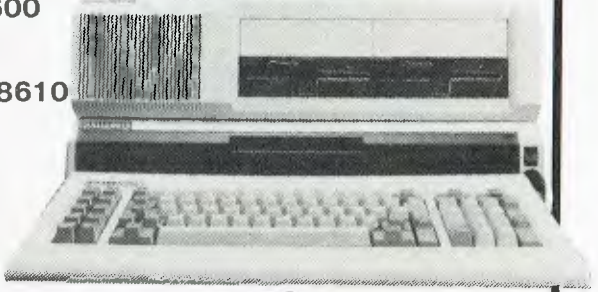

System Unit Cat X-8600

**\$995**

Expansion Unit Cat X-8610

**\$1995**

BOTH FOR  
**\$316 dep \***  
& **\$23.54 weekly**  
over 48 months



SCOOP PURCHASE

## Panasonic 120 CPS Dot Matrix Printer



Cat X-3260

Compact, high performance unit - quality printing in various formats, including proportional spacing & graphics. A sturdy no-nonsense printer that will work hard all day, every day.

Recommended Retail was \$975  
Save \$380. Our price **\$595!**

## Incredible! VZ-200 Colour Computer

What a saving! Current catalogue price \$169 ... now an amazing \$99!!! But hurry - limited stocks at this crazy, crazy price. With full range of accessories available and programs to suit every purpose you can't go past the fantastic VZ-200!

**\$99**  
Cat X-7200

**OVER 25,000 SOLD!**

- VZ-200 Datasette Cat X-7207 \$69.50
- 16K Expansion module Cat X-7205 \$79.00

• 4 Program Pack Special  
3 different sorts to choose from, each with 4 programs. Educational (X-7292), Financial (X-7293), Entertainment (X-7291). Separately \$50  
**Now only \$19.95**



**UNBEATABLE PACKAGE OFFER!**  
Purchase the VZ 200, the VZ Datasette, the 16k Expansion module and your choice of two 4 program packs for

**JUST \$229** USUALLY \$287, SAVE 20%: \$58!!  
or \$34 deposit and \$3.00 per week over 24 months.

\* Custom Credit  
Finance available to approved applicants

## FANTASTIC OFFER!

2 Disks for the price of one from XIDEX! (5 1/4" Floppies)

See coupon in most computer magazines plus EA & ETI. Don't miss out.

Last chance - closes 31st October.



Dick Smith Electronics Pty Ltd

# COMPUTERSTOP™

Figure 1. Diagram of a basic direct-connect modem.

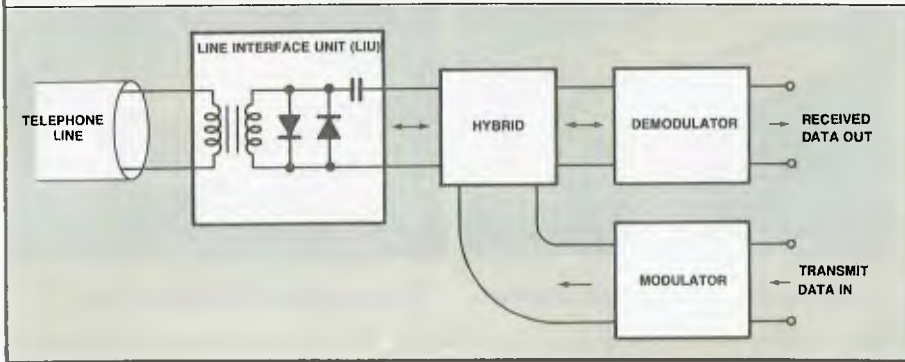

waiting at the other end. At the other end another modem receives and translates the incoming signals. If it gets a tone signifying zero or one, it sends a zero or one to the computer's communications port. It's that simple; well, almost.

The modem can convert signals and transfer them in a variety of ways. It can actually generate a sound using a speaker which feeds into the normal telephone handset, or it can generate the electrical equivalent of the sound and send it directly up the line. These two techniques are called acoustic coupling and direct-connect, respectively. The direct-connect method is preferred, and more common, because acoustic coupling is more prone to errors.

The crucial factor with acoustic couplers is that the carbon microphone found in most phones tends to be noisy, and the carbon granules inside pack up (like cereal settling in a packet of Corn Flakes). While there is no effect when your Corn Flakes compact, the effect on your signal is that it loses volume and becomes more and more distorted. One solution is to give the mouthpiece a light tap from time to time, to loosen the granules, but eventually even this loses its effectiveness.

Another difference between modems is the technique they use to determine if they are sending or receiving. There are two techniques: full and

half duplex.

With half duplex, one modem sends while the other receives. Neither modem can send and receive at the same time. When one modem is finished sending, it signals the receiving modem, which then switches its state to begin sending while the other switches ready to receive. This can be a bit of a pain if you want to be able to send and receive all at once, like when interacting with another user, or a system like *Your Computer's Bulletin Board*.

Full duplex addresses this problem, and thereby becomes a little more complex, as it uses two frequencies of sound to send and another two frequencies to receive. One modem sends on one pair of frequencies and listens on the other, while the other modem does the reverse. Which modem uses which frequencies depends on a standard that says the modem which 'ORIGINATE's the call uses one set and the modem which 'ANSWER's the call uses the other. All full-duplex modems can be switched to one or the other state; some can be switched using software.

The sending frequencies vary between modem standards. The two main standards are CCITT V21, which is the common standard in Australia for transfer at 300 baud, and Bell 103. There are several others around, but the one you are

# Call me Modem

most likely to come across in Australia is CCITT V21. V23 will also pop up, as it is the most common standard for 1200-baud communications. There are some non-V21 type modems mentioned at the end of this article, so keep an eye out. Modems, like headache powders, are not all alike. Also, be careful if you order or buy a modem overseas. Find out what standard you need and make sure the modem you buy can comply with it. The best test is to hook it up to your target system and check it out — a little difficult if you are buying by mail order, but that is the risk you take.

## Modem Developments

The current state of play, with microcomputers at least, tends to revolve around 300-baud modems. The baud rate refers to the speed of data transfer. In fact, it is more correct to refer to transfer rates in bits per second because 'baud' refers to changes in bit state per second. The two terms, while slightly different, are becoming interchangeable. To avoid confusion we will refer to them as baud rates.

Three-hundred baud is quite slow. Many modems are capable of much higher speeds, often at much higher prices. However, cheap but effective 1200-baud modems are beginning to appear on the micro horizon. Some are available at modest cost right now, while others should be available in a number of popular brands within the next six to twelve months.

Modem technology, being relatively simple, lends itself readily to miniaturisation. There are a few problems in isolating signals from each other, but it may soon be possible to provide all modem functions on a chip built into the computer. Already there are computers which can take inbuilt modems.

## Possible Problems

Apart from the potential disaster of buying a modem which is non-standard and which can't be used to talk to anyone, there are also problems of line quality. Put simply, the quality of some telephone lines in Australia is so bad it is nearly impossible to send data using modems. According to the Managing Editor of *Your Computer*,

Table 1. Modem frequencies for common CCITT and Bell standards.

	CCITT V21 300/300 baud	CCITT V22 1200/1200 baud	CCITT V23 1200/75 baud	BELL 103 300/300 baud
Answer			Forward channel	
0 (space)	1850 Hz	2800 Hz	2100 Hz	2025 Hz
1 (mark)	1650 Hz	2000 Hz	1300 Hz	2225 Hz
Originate			Return channel	
0 (space)	1180 Hz	1600 Hz	450 Hz	1070 Hz
1 (mark)	980 Hz	800 Hz	390 Hz	1270 Hz

# Call me Modem

Jim Rowe, his attempts to design one of Australia's first direct-connect modems for private owners were fraught with concern over the ability of the modem to perform properly in an environment where you are trying to send out data without it leaking into your received data, while also trying to accommodate huge differences in the electronic properties of the telephone lines.

The consequence of this situation is that cheaper modems and faster modems tend to get corrupted incoming data more frequently than modems with more sophisticated circuitry which can handle these fluctuations.

## Telecom - a Major Player

No discussion of modems is complete without a mention of the role of Telecom. Telecom owns the phone lines and consequently tends to dictate policy on what can and cannot be connected to either end of them, and by whom, and perhaps most importantly, for how much. The reasoning behind its regulations might be that if everyone were allowed to connect anything to the phone lines, the odd Telecom technician would get toasted by some idiot connecting something lethal.

This situation is undesirable because while Telecom policy makers may not be everyone's friends, the reverse applies to the Telecom technician. Telecom technicians are



The Cicada 300T from Centre Industries.



The Sendata 300, from Electromed.

our friends and will help us whenever they can. So don't break the rules, and do your best to ensure their safety at all times.

Another consideration in this area is the need to avoid excessive current and voltage in lines, which could cause crosstalk; that is, leakage of your communications into other lines and circuits.

In the bad old days, the only way to get a modem was to rent it from Telecom at exorbitant expense, and have them come to install it for you. The only modem you could connect yourself was an acoustically coupled modem, which was not actually wired to the phone. Numerous battles later, it is now possible to buy a modem from a store, take it home and plug it in yourself. The modem must be Telecom approved, however, which should be stated somewhere on the packaging.

One point of interest is that when Telecom first approved the public use of modems, the rule was you had to get a special plug to connect it to the phone line. Then it was discovered that if the modem had a phone attached to it, you could use a

normal phone plug and just plug it in yourself. Thus, many modems have that little phone, which costs only a couple of dollars, stuck on top and wired into the modem. These are not as much a feature added for convenience, as the result of careful navigation of Telecom regulations in order to avoid buyers having to pay big connection fees.

## The Modem Market

There is a proliferation of modems in the Australian market. Many of them, it is pleasing to note, are made and manufactured locally. Several major microcomputer manufacturers can supply a modem specifically designed for their machines. Microbee, for example, markets the Beemodem for around \$150. Apple has a modem selling for around \$500.

Apart from these vendors, there is a number of companies specialising in the voice and data communications industry, which market some excellent modems. *Your Computer* surveyed the market, and Table 2 lists all those who responded to our requests for information on their products.

Table 2. Modems available in Australia; others are probably available, but no information was forthcoming when we asked suppliers for it!

Modem	Supplier	Speed	Protocols	Price	Comments
Shuttle 300	R.F Computer Communications 2 Rosedale Grove Frankston VIC	300 baud full duplex	CCITT V21	\$239	Option to connect with Commodore 64 and Vic 20.
Multimodem	Avtex Electronics 119 York Street Sydney	300 baud 600 baud 1200 baud	Bell 103, 202 CCITT V21 CCITT V23	\$329	
In/Modem	Data Net Comm 8/33 Ryde Road Pymble NSW	300 baud 1200 baud 1200/75 baud	Bell 103, 202 CCITT V21 CCITT V23	\$795	Mounts inside and IBM. Has auto answer and auto dial.
Datasat V2123	Datasat, Suite 5 522-524 Kingsway Miranda NSW	300 baud 1200/75 baud	Bell 103, 202 CCITT V21 CCITT V23	\$350	Optional auto dial and answer.
Datasat V21	As above	300 baud	CCITT V21	\$195	
CDS V22	Datacraft Maroondah Highway Croydon VIC	600 baud 1200 baud	CCITT V22	\$1490	Optional auto answer.
5003M	As above	300 baud	CCITT V21	\$299	

# Computing Software

## ATARI GAMES AND RECREATIONS

**K0224P \$22.25**  
Beginners and advanced users can use the preprogrammed games in this book to improve their skill. Charts, flash cards, an error dictionary and graph paper designs are among the features.

## TRS-80 ASSEMBLY-LANGUAGE MADE SIMPLE

**K0208P \$19.25**  
If you have an understanding of BASIC programming, this will help you to plan, write and hand-assemble your own assembly-language programs in memory, using the T-bug and Level II BASIC ROM subroutines.

## USING THE 6800 MICROPROCESSOR

**J0163P \$13.25**  
Guides the reader through the conception, configuration, writing and running of a variety of programs that demonstrate practical use of a 6800 system.

## APPLE II ASSEMBLY LANGUAGE

**K0195P \$23.45**  
Teaches assembly-language programming at the beginning level — no prior knowledge of 6502 assembly language is needed. Includes hands-on computer exercises and experiments, with both software and hardware. Provides interfacing circuits and programs that can be used on the Apple II without modification.

## CP/M PRIMER

**K0191P \$26.95**  
A complete one-stop course on CP/M, the very popular operating system for 8080, 8085 and Z80-based microcomputers. Complete terminology, hardware and software concepts, startup of a CP/M system, and a complete list of CP/M-compatible software.

## COMPUTER GRAPHICS PRIMER

**K0180P \$21.95**  
Almost every page has a colour drawing, photograph, picture or a schematic to help you learn computer graphics quickly and easily. Programming concepts apply to all microcomputers, and examples are given in BASIC for the Apple II.

## MICROCOMPUTER DESIGN AND TROUBLESHOOTING

**J0161P \$26.75**  
Tells you how to design microcomputer systems and make them work without an expensive commercial development system or the need for costly test instrumentation. Includes a complete description of two microprocessors — the 8085 and the 6502.

## PC DOS: USING THE IBM-PC OPERATING SYSTEM

**J0278J \$24.50**  
This self-paced guide teaches you how to become an accomplished user of all the major disk-operating system functions and utilities, no matter how much or how little computer experience you have.

## FIFTY BASIC EXERCISES

**K0188A \$17.95**  
Designed to teach BASIC through actual practice, this book contains graduated exercises in math, business, operations research, games and statistics. The programs were designed to run directly on a TRS-80 but will run on any system with Microsoft BASIC.

## THE ART OF PROGRAMMING THE 16K ZX81

**K0213B \$8.75**  
A sequel to *The Art of Programming the 1K ZX81* (ETI Book Sales No K0226B), this book sets out to help you use your 16K RAM pack and ZX printer to the full. It concentrates on good programming style and introduces some interesting programs that are both fun and useful.

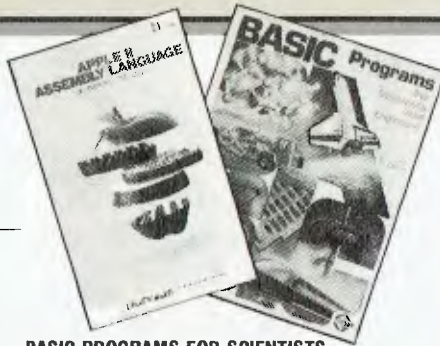

## BASIC PROGRAMS FOR SCIENTISTS AND ENGINEERS

**K0179A \$19.95**  
Contains scientific and engineering application programs written in BASIC.

## APPLE MACHINE LANGUAGE

**K0215P \$21.95**  
This straightforward book teaches machine language programming through BASIC, the transition being made step-by-step. Many sketches of video displays are provided, as well as exercises.



# Book Sales

ETI Book Sales,  
140 Joynton Ave.,  
Waterloo, NSW 2017

(02) 663-9999,

## DON LANCASTER'S MICRO COOKBOOK

**J0159P \$22.20**  
This 'cookbook' starts with the very fundamentals of microprocessors and microcomputers and takes you through number systems, codes, etc, till you can work intelligently with micros.

## THE \$100 AND OTHER MICRO BUSES

**J0160P \$14.50**  
The key to successful computer expansion is a complete understanding of the bus system, through which the computer communicates with peripherals. This book will give you that understanding.



## THE 6809 COMPANION

**J0154B \$6.95**  
This is not a beginner's introduction to microprocessors in general but a discussion of the features of the 6809 and a reference.

## Z80 MICROCOMPUTER HANDBOOK

**J0171P \$20.50**  
This handbook covers hardware, software and microcomputers built around the Z80.

## APPLE INTERFACING

**J0273P \$15.95**  
Using this book, you will be able to perform useful experiments which will provide a much clearer understanding of the fundamentals of computer interfacing and computer electronics.

## 6502 APPLICATIONS BOOK

**K0228A \$20.95**  
Use this book and a few low-cost components to build a complete home alarm system, an electric piano, a motor speed-regulator, a time-of-day clock, a simulated traffic control system and a Morse code generator, etc.

## Z80 MICROCOMPUTER DESIGN PROJECTS

**J0156P \$20.75**  
A complete look at the internal architecture of the Z80, the heart of many microcomputers, and even shows how to build a microcomputer, the EX80, using this powerful chip.

## MICROPROCESSOR CIRCUITS

**J0157P \$14.75**  
Presents basic microprocessor concepts in simple language for beginners and teaches you to construct a useful microcontroller system. Offers 30 demo circuits which take you through assembly, operation and programming of a microcontroller.

## A Z80 WORKSHOP MANUAL

**J0283B \$8.95**  
Intended for those who want to progress beyond BASIC programming to topics such as machine-code and assembly language programming or who need hardware details of the Z80-based computer.

## EASY ADD-ON PROJECTS FOR SPECTRUM, ZX81 AND ACE

**J0285B \$7.75**  
The projects include a pulse detector, picture digitiser, five-key pad, model controller, bleeper, lamp flasher, light pen, etc, etc.

## THE 68000: PRINCIPLES AND PROGRAMMING

**K0176P \$19.95**  
An easy-to-read, systematic approach to the 68000 advanced 16-bit microprocessor. The book guides you through the complex architecture, instruction set, pinouts and interfacing techniques. Written for design engineers, programmers and students.

## ENHANCING YOUR APPLE II

**K0206P \$27.95**  
Contains fast and easy method for taking apart and understanding machine-language programs. Features programs and other hints for creating hundreds of colours or many patterns on the screen, plus ideas to improve text on high-resolution displays.

## TV TYPEWRITER COOKBOOK

**J0297P \$14.50**  
A complete guide to low-cost television display of alphanumeric and graphics data for microprocessor systems, computer hobbyists, television titling, word-processing and video games.

## STD BUS INTERFACING

**J0164P \$21.75**  
Explains what the STD bus is, in easy-to-understand language.

# Computer Hardware & Techniques

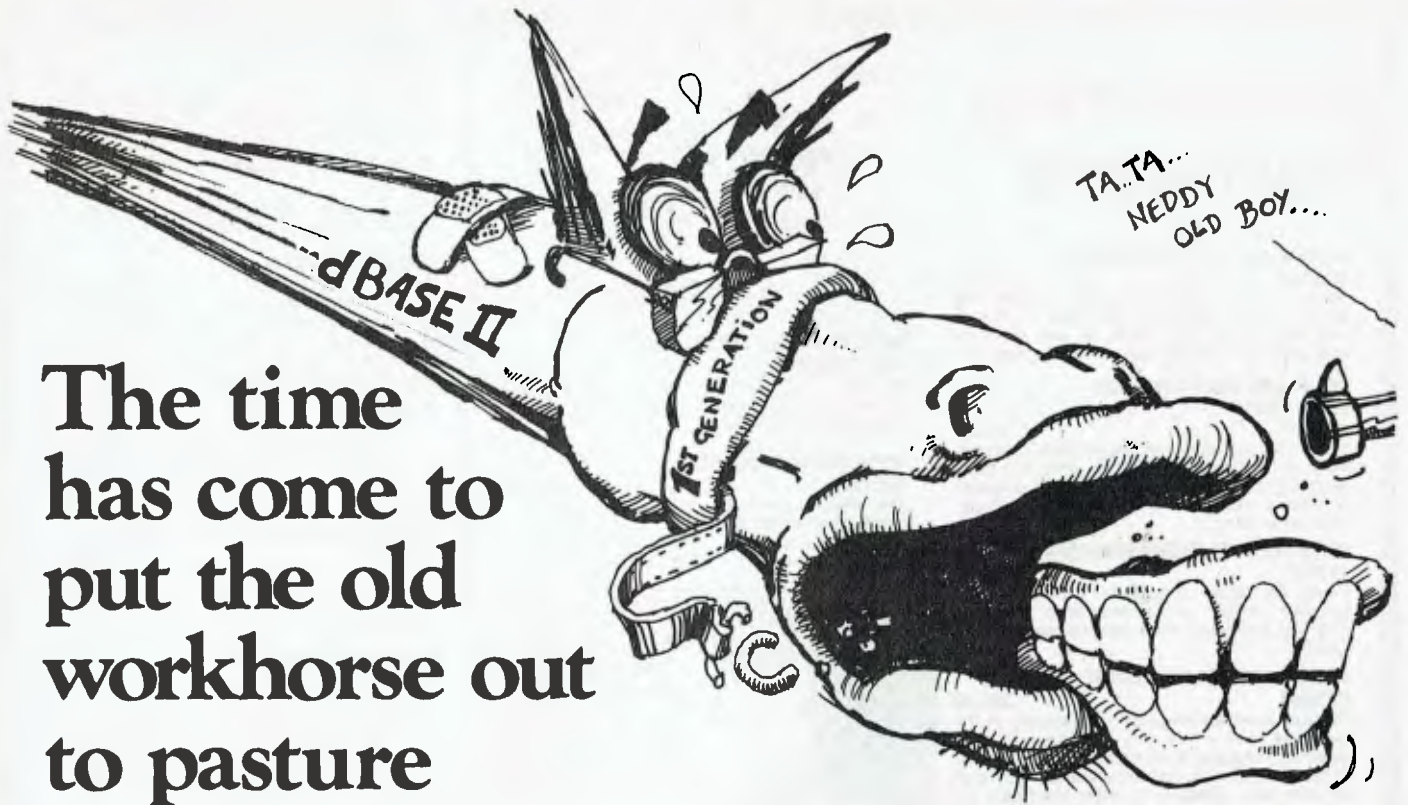

# The time has come to put the old workhorse out to pasture

The days when dBASEII\* stood all by itself at the apex of the database management pyramid are past. The old workhorse has been put out to pasture by a new breed of faster, easier, more powerful packages. It's not that the old horse hasn't done its job: it has, gloriously. Those of you using dBASEII know that it has paid for itself many times over. In its time it was dBest. And now there's no denying that it's slow, it's cumbersome, it's difficult to live with — when you compare it with some of the newcomers on the market.

## Fresh out of the starting gate.

So who are the newcomers that have usurped the old master's position?

### Delta:

We regard it as the most complete user-oriented database system on the market today and for the foreseeable future. Delta caught our attention when it received the UK government's prestigious RITA award for "best software of its kind", followed closely by IBM UK's adopting it as their own distributed product for the IBM PC. Everything we have learned about it since working with it here has served only to increase our enthusiasm. Delta has so much to offer — and you don't have to be a programmer to get it all.

### Dataflex:

Dataflex is a true multi-file, multi-user database management system. "Flex" offers you unlimited flexibility in the development of high quality, easy to use database applications — in a minimum of time. "Flex" is for software developers everywhere, as well as for users with complex applications.

## Take some advice from experienced punters.

"Dataflex . . . truly the best application development tool on the market today. Its power and flexibility have enabled us to write a total package in less than 50% of the time compared to conventional methods."

**Tim Lambertson, M Sc.** software consultant to Occidental Life.

"Dataflex allows the developer to devote his energies to good systems design because the nitty gritty of screen, file and report routines are superbly handled by Dataflex. The end user has the knowledge that his system can be easily modified and further enhanced."

**Jeff Hooper** Talon Systems

## Place your bet on a winner.

Delta and Dataflex are available at leading computer stores everywhere. Ring your local dealer and ask for a demo. If he doesn't know about the product you're interested in, ring us. Or better yet, have your dealer ring us. It's time he got on the inside track.

Delta and Dataflex distributed in Australia by

# Intelligence

(AUST. PTY. LTD.)

**Sydney:** 60-64 Shepherd Street, Chippendale, 2008.

Phone: (02) 699 3877. Telex: AA25331.

**Melbourne:** 123 Moray Street, Sth. Melbourne, 3205.

Phone: (03) 690 6600. Telex: AA38027.

**Brisbane:** (07) 343 9122.

**Perth:** (09) 322 1677.

Modem	Supplier	Speed	Protocols	Price	Comments
5000 Multimodem Mark II	As above	300 baud 1200 baud 1200/75 baud	Bell 103, 202 CCITT V21 CCITT V23	\$700	
Cicada 300	Centre Industries 187 Allambie Road Allambie Heights NSW	300 baud	CCITT V21	\$289	
Dataphone II	Dick Smith	300 baud	CCITT V21	\$199	
SB321	Case Communications 1-3 Rodborough Road Frenchs Forest 2086	300 baud	CCITT V21	\$557	
SD2000	As above	300 baud 1200 baud 600/1200 baud	Bell 103, 202 CCITT V21, V23	\$703	
SB7512	As above	75/150/1200 baud	CCITT V23	\$555	Viewdata originate mode
SB1275	As above	75/150/1200 baud	CCITT V23	\$501	Viewdata answer mode
Case 1212 Smart Modem	As above	1200 baud	CCITT V22	\$1437	Error checking built in, auto answer
Sendata 1200	As above	75/600/1200 baud	CCITT V23	\$345	
Sendata 700	As above	1200 baud	CCITT V21/23	\$322	Acoustic coupling
Sendata 300	As above	300 baud	CCITT V21	\$288	
Beemodem	Applied Technology 1 Pattison Ave Waitara 2077	300 baud	CCITT V21	\$150	
ETI Modem	Jaycar Electronics Rod Irving Electronics ETI for printed circuit boards only	Variable	Variable	\$170 \$50 (PCB only)	Transfer rates and frequencies variable by user. Not Telecom approved but meets standards. Only in kit form.
NetComm Modem	DataNetComm 8/33 Ryde Rd Pymble 2073	300 baud 1200 baud 1200/75 baud	CCITT V21/23	\$495	Plug-in internal modem for Apple II family.

**★ ★ REVOLUTIONARY PRICE  
★ ★ BREAKTHROUGH! ★ ★**

## C.S.S. INTRODUCES "PLASTIQUIET"

The economical Acoustic Hood.

**ONLY \$294** tax inclusive!

A very generous 755 (wide) x 530 (deep) x 280 (high)mm.  
Fits most dot matrix and daisy wheel printers! Vented for economical air circulation. Slotted for continuous paper exit, cabling exits also provided.

The Acoustic Hood is fabricated from 5mm A.B.S. plastic and 4.5mm perspex.

**OPTIONAL EXTRAS:** Fan **\$67.00** tax inclusive ★  
★ Base **\$20.00** tax inclusive ★ Stand **\$110** tax inclusive.

**DEALER ENQUIRIES INVITED**



**COMPUTER  
SITE SERVICES  
PTY. LTD.**

Incorporated in N.S.W.

**UNIT 4,  
52 STANLEY STREET,  
PEAKHURST 2210  
PHONE: (02) 53 7980 &  
53 8831**



*Has Sinclair done it again? Will the QL – short for Quantum Leap – turn out to be another success story like the Spectrum ... or has Sinclair's fertile brain finally spawned a real turkey? Despite the fanfare that surrounded Sinclair's latest release in the UK, Tim Hartnell felt a close look at the QL might show up a few flies in the ointment.*

# How Far Will a Quantum Leap?

THE QL raises a number of questions. Why was it announced so prematurely? Is it worth the almost \$700 it's being sold for in the UK? Is the 'free' software of any real value? And so on. The QL has been surrounded by misinformation since the beginning, and Uncle Clive – no stranger to criticism – has come in for more than his usual share during the first four months of this year, since the announcement of the machine in January. In this review, I'll attempt to provide answers to some of the questions I've raised.

Most computer reviews concentrate on the machinery, the hardware, and leave the ideas which lie behind the

machine, the concepts the designers tried to embody in it, for other, later commentators to examine. But the *concept* of the QL and the ideas which lie behind its resident language, 'SuperBASIC', are fundamental to understanding the machine; so they must be discussed, along with the hardware.

## The Cutting Edge

"Those who operate at the cutting edge of technology shall be sacrificed upon it," observed Adam Osborne, and Clive and his staff have been proving the truth of that pronouncement since QL launch day. From extraordinary (even by Sinclair's standards)

delays in delivery to strange rumours that, perhaps, the machine might never even appear – the QL attracted a lot of flak. I was amused to see that internal Sinclair documents on the QL referred to it as the 'ZX82', and I guess now that was also its working designation within Sinclair Research.

As a way of compensating for delivery delays, and lost interest on money forwarded for the computers, Sinclair is sending out the RS232 lead which normally costs nearly fifteen pounds (about \$25) as a 'free gift' with all QLs which have taken longer than 28 days to deliver. This will happen even if the QL was ordered via credit card, and the amount was not deducted from the card until the computer was sent out. If a customer ordered the RS232 lead, Sinclair will send his or her money back.

One of the reasons for the delivery deals is evident when you see the machine. The QL does not fit within its natty dark-grey case. "We can't get all the operating system in," a spokesman confided. So sticking out of the ROM socket at the back of the QL is a blob of metal, slightly larger than a matchbox, which contains the bits of the computer which Sinclair couldn't squeeze into the case. Eventually, if it is ever done, QLs will be going out without the extra blob at the back, but Sinclair felt it was more important to quieten the clamour over protracted delivery delays (even if it meant

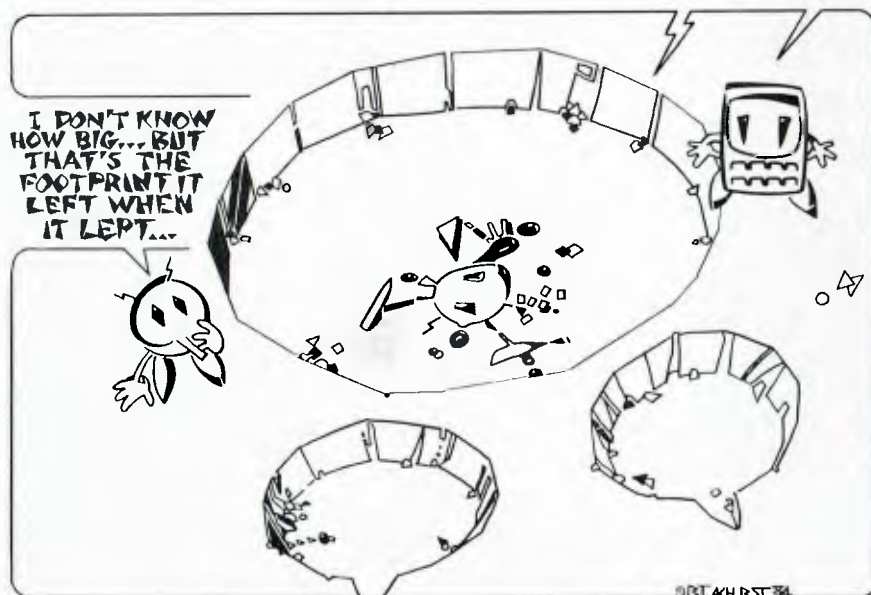



sending out 'cobbled together' machines) than it was to delay the whole thing until they got it right.

Sinclair Research intimated – without ever saying it straight out – that if the QL without this compulsory blob of metal is significantly better than the first edition deliveries, there would be some facility for exchange. No hints as to how this would occur were volunteered.

It seems the QLs shown at the tumultuous press conference in January did not contain all the computer. It has been no particular secret within the industry that Psion – the company which developed the four software packs supplied 'free' with the QL – did not have access to anything like the final version of QDOS when they were writing the programs. (QDOS is the QL operating system which looks after such things as task scheduling and resource allocation). And if conversations taking place while I was at Sinclair Research in late April were any indication, it seems that QDOS was far from being finalised even then, only ten days before the first machines (on the greatly delayed delivery schedule)

were due to go out.

For example, Nigel Searle (managing director, Sinclair Research) told me they were thinking of radically changing the way the microdrives accessed programs. At present, the QL finds the first block of data which makes up the program, then keeps the tape spinning until it comes to block two, then once it has digested that, looks for block three, and so on. The modification would allow the computer to accept the blocks out of order, thus greatly minimising the time it takes a program to load. I timed the loading of Quill, the word processing program provided with the computer, and found it took 70 seconds from the time loading began until the program was ready to use. This may not seem very long if you're used to cassettes, but it is an age compared to normal disks.

There are now three different 'editions' of the Spectrum around, and it seems obvious that there will be at least two editions of the QL. There may well be more than two editions of the software packs. I found two spelling errors in the help menu for Quill when I was reviewing the

software (though I knew, and it is only fair to point it out, that I was only using a late development version of the software rather than the final version), and was given the impression that correcting these errors would be incredibly easy. This was, as I've said, just ten days before the first product was due to leave the warehouse.

### Down to the Nitty-Gritty

Right, now that we've looked at the fun and games concerning the first QLs which will be released, let's see what sort of computer it *really* is. Many early 'reviews' of the machine were based on the press release, plus two minutes' 'hands on' at the press conference. I spent many, many hours with a QL, trying to assess it completely.

The photographs with this review show what the QL looks like: a long, blackish case, with the microdrives occupying the right-hand 15 cm, and the rest of the 48 cm length occupied by the keyboard.

The machine is light, but does not appear particularly fragile. I tried to 'wring' the computer (as one would a

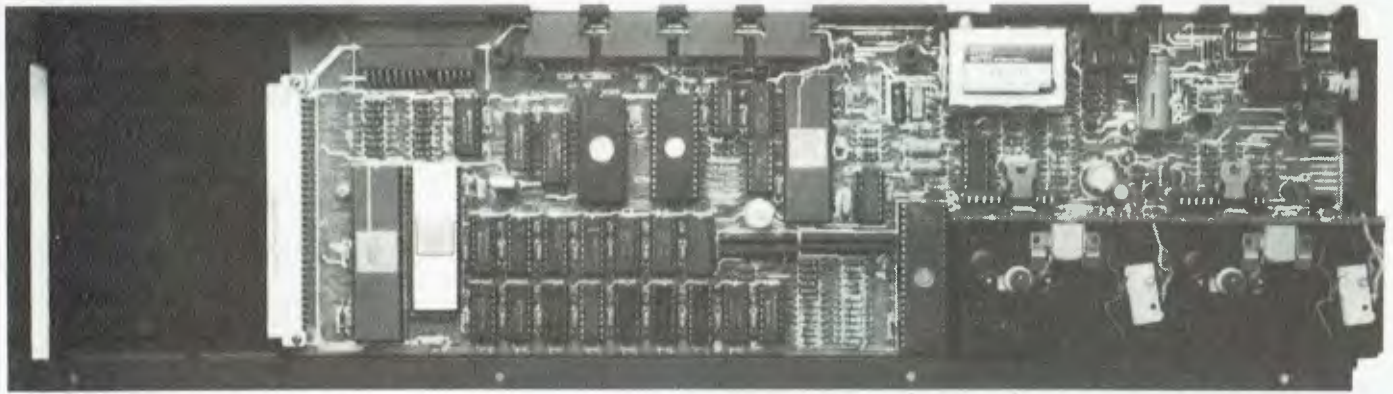

Inside the QL: two processors (a 32-bit Motorola MC68008 main processor, and an Intel 8049 to control the keyboard, sound, and act as an RS232C receiver), and two custom-designed chips to control display, memory, the microdrives, the real-time clock, local area network, and RS232C transmission.

wet towel) and there was very little give, and no ominous cracking sounds. The horror of losing the 16K RAM pack off the back of the ZX81 – which meant you treated the machine with great care – does not seem necessary with the QL. Even shaking it fairly violently (far more so than would occur in normal use) failed to dislodge the ROM pack, or to disturb the image on the TV screen.

Sinclair keyboards were one of the main sources of complaint on earlier machines. You use the keyboard nearly all the time when interacting with the computer, and any design failure at this point becomes a constant irritation. The QL is about 3.75 cm thick, which means when it is lying flat on the table the keyboard is not particularly easy to use. However, the machine is supplied with three little plastic 'feet' which stick on the bottom of the QL and allow it to be tilted forward, to an angle which I found extremely convenient. I was reluctant at first to stick the feet on because I thought the ROM might fall off the back, but this proved to be an unfounded fear.

The keyboard itself was a surprise – a very pleasant one. As I spend a lot of my waking hours working with keyboards (generally word processing on an IBM-PC, or writing with an electric typewriter), I am accustomed to keyboards which work *with* rather than against me. I have become boringly impatient with crummy keyboards, and with design faults which mean the keyboard can't keep up with me when I type quickly. The QL is surprisingly satisfactory to use.

The keys are made up of separate keytops sitting on a membrane keypad below, but the membrane

construction is not evident from using the keys. Although there is a slight need to press the keytops down (rather than just tap them as would be the case with an electric typewriter), only the slightest push is needed to get them to work. The keytops are moulded, so fast and accurate program entry is easy. The keys auto-repeat after about a third of a second. The space bar (thank goodness we have a space bar this time, rather than a space key) rattles a bit, but this is not particularly important. The enter key is a large, L-shaped key on the right; there are *two* (thank goodness again) shift keys; and ESC is up near the top left-hand corner of the keyboard. A reset key is hidden down the side, next to the microdrives. It is easy to press without looking for it, but is unlikely to be pressed by accident (which is just as well, as it performs

a total RAM wipeout).

My only criticism of the keyboard lies in the position of the cursor keys. To the left of the space bar are the 'left' and 'right' arrows, while the 'up' and 'down' arrow keys are to the right of the bar. I'm sure you'll get used to them in that position, but I found their initial use far from intuitive.

No such criticism can be aimed at the position of the five function keys, which form a straight line down the left-hand edge of the keyboard. They are easy to use in this position (far more so than the horizontal row of keys on the BBC Micro, above the other keys) and are used frequently in the four software packs. For example, function key four is used in Quill to change the typeface.

Sinclair has at last abandoned the 'single-touch keyword entry system' which, to date, has been a hallmark

**Reset button:** Allows the computer to be cleared without disconnecting the power supply.

**Microdrive extension slot.**

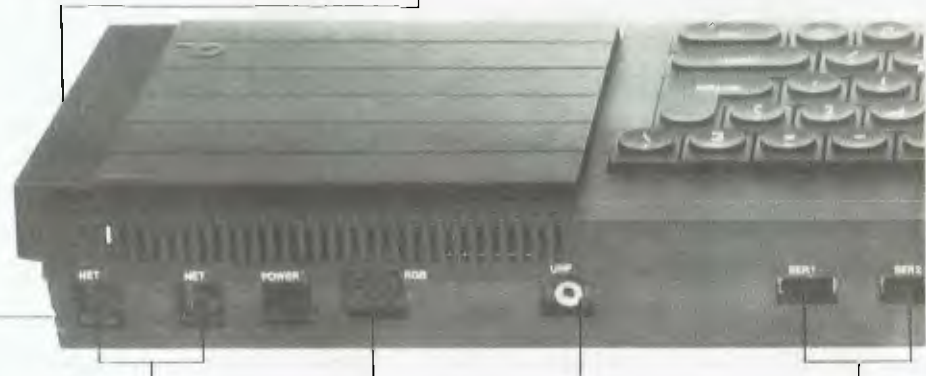

**Local area network – QLAN:** High-speed communications link for up to 64 QL and Spectrum computers.

**Monitor port:** Two modes are available – 512 by 256 pixels, giving four colours, and 256 by 256, giving eight (or eight grey shades). Normal format for characters is 80 columns by 25 rows, and a choice of character sets is available.

**TV port:** Display modes for a TV are the same as for a monitor, but normal format is 40 to 60 columns, depending on the software. Colour or mono TVs may be connected.

of his designs. You now type the relevant word (such as 'for') in full. You can do this in upper or lower case, and the computer will automatically change the word to upper case in the listing. I'll have more to say about this in a moment, but for now let's turn the machine on and see what you'll experience when you first plug it in.

### Starting Up

There is no on/off switch. The QL comes with an external power supply, slightly taller than that provided with the Spectrum, but in the same family. A generous lead is provided, with the power supply unit sitting in about the middle of this lead. When you turn the power on, the screen fills very briefly with parallel and vertical green and red strips - assuming you're using a colour TV or monitor. This is replaced with 'high-res rubbish' while the QL does a little internal checking. The screen clears to black, and the following message appears at the bottom of the screen:

```
F1 ... monitor
F2 ... TV
(c) 1983 Sinclair Research.
```

The reference to F1 and F2 is printed in red on a white oblong, surrounded by a green border, while the copyright message is in white on a long, red strip. If you press function key one (to indicate you have a monitor connected to the socket marked RGB) the screen clears to show a rectangular area which fills about two-thirds of the screen. The

left half of this rectangle is white, the right half is red. If you press function key two (to tell the QL you have a TV attached to the UHF socket), the screen clears completely to white.

There are two graphics modes: Mode 256, which is the lowest resolution mode (with, as expected, 256 pixels across); and Mode 512, which is double the 256 resolution. The QL falls into 256 if you press TV (with a square, purple, flashing cursor) and into 512 if you press for the monitor (with a thin rectangular cursor, flashing red). You can display eight colours (blue, red, magenta, green, cyan, yellow, white and black) on the 256 by 256 screen, while only four are available (black, red, green and white) in the 512 by 256 mode. Many other colours can be created using the various 'stipple' combinations. There are four stipple patterns (vertical bars, horizontal bars, big foreground dots, small foreground dots), which allow an enormous range of colours to be created. I worked out a program which combined use of the contrast, foreground and stipple commands, which appeared to generate 255 different-coloured screens.

Back to the opening frame when you first turn the QL on. If you work with a monitor, or with the QL sending out the monitor high-res signal, there is a real delight awaiting you when you enter your first program. As you type on the keys, the program you're entering appears in green on the black area below the white half

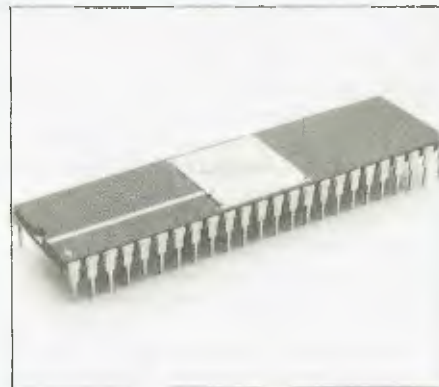

The main processor, a 32-bit Motorola MC68008.

of the coloured rectangle. But each time you press 'enter', the program line reappears in red on the white area above you. There is room for four lines of program below the white area. Once these four are filled, the top one scrolls up 'under' the white area, and vanishes. Similarly, commands like RUN (and even direct entries such as CLS) stay in place in the black area, even after they have been executed.

When you enter the program, it appears line by line in red on the white square above you. If you decide to enter a new line with the same line number as one already in place, the new line automatically takes the place of the original line, in position within the program automatically. It does not sit at the bottom of the listing, waiting until you 'list' the program before appearing in its correct place.

The real magic is to come. Remember, you're in the high-resolution mode, with half the rectangle in white (with the program printed on it in red) and the other half of the rectangle in green. Type RUN, and the program runs in white type on a red background down the right side of the screen (other colours can be specified). Your program listing stays in place. So you can see the listing on one side, and the effect of running that listing on the other side, at the same time.

If you are in Mode 256 when the screen clears to a white rectangle, the program listing appears in red on the white as before, but with each character stretched twice as wide as in the higher resolution mode. However, when you type RUN and press 'enter', the program starts running at the top of the white area, overwriting the program listing, and

ROM cartridge slot: Accepts one QL ROM cartridge; up to 32K ROM is possible.

Expansion slot for 0.5M memory board and forthcoming peripherals.

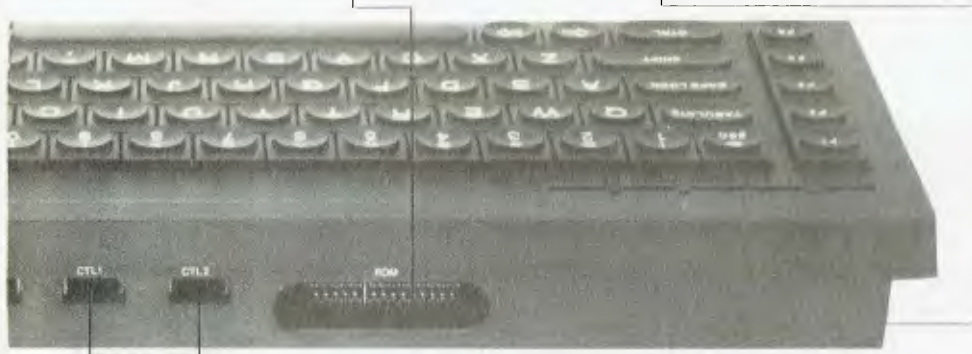

RS232C: Two standard interfaces for peripherals such as printers and modems; transmission rates from 75 to 19,200 baud, transmit/receive in full duplex at seven rates up to 9600 baud. (A parallel printer interface is said to be available as an optional extra.)

Joysticks: One or two joysticks may be added for games or cursor control; cursor control is also provided by four separate keys on the keyboard.

The QL has nine peripheral ports, as well as the expansion slot and the Microdrive extension slot.

## Sinclair QL

prints in white on little red squares of 'paper' as it goes. The screen does not clear, unless you have CLS within your program. If you do include CLS, the screen will clear to red (unless you specify another 'paper' colour, like you can on the Spectrum), and the 'ink' defaults to white.

A clue to one of the features of SuperBASIC is given if you examine the program listing carefully. Certain programming words are spelt in full within the listing, even if you only entered them as three letters. For example, if you include 'REM' in your program the QL will change it (in the listing which appears at the top of the screen) to 'REMark', with 'REM' in upper case, and 'ark' in lower case. This happens with many other commands, such as DIMension and DEFine PROCEDURE.

### SuperBASIC

This leads neatly into a discussion of SuperBASIC, the language supplied with the QL. The production models will have, as an extra included since the launch of the computer, what was described to me as 'turtle graphics'. No clues were given on how to access or implement these graphics.

'Turtle graphics' aside, the main thrust of SuperBASIC is to encourage (if not force) more structured programming than is usually the case with BASIC. The BBC Micro's resident BASIC contains such things as procedures to encourage structured programming, but the idea is extended considerably on the QL. Although GOTO and GOSUB are provided in SuperBASIC, the manual claims this is only to give some kind of compatibility with existing BASICs. "They are not needed," we are told sternly.

The QL can be used more or less

like a Spectrum, programming in Spectrum BASIC and getting similar results. But to work in this way ignores the power of SuperBASIC. For example, repetition (controlled by either a FOR/NEXT loop, or an endless loop which ends with a GOTO back to the beginning, in 'standard' BASIC) can be controlled in SuperBASIC by two 'constructs':

```
REPEAT identifier statements
FOR identifier = range statements
or
END REPEAT identifier
END FOR identifier
```

These two sections of code are used together with another two words from SuperBASIC's vocabulary:

```
NEXT identifier EXIT identifier
```

Processing a NEXT statement will either pass control to the statement following the appropriate FOR or REPEAT statement, or if a FOR range has been exhausted, to the statement following the NEXT.

Some of the explanations of SuperBASIC seem fiendishly complex, but as I said, you can proceed fairly happily with the QL as though it was a Spectrum for a while, and then gradually introduce bits of QL magic into your programs.

One of the complaints made by programmers against the highly structured programming language Pascal is that it is a self-righteous, school-marmish language, which doesn't allow sloppy misbehaviour even if you want to exercise it. The same tone seems to have crept into the thinking behind SuperBASIC ('Ve haf vays of making you program better').

### No Need to Freeze

After I'd been using the QL for a couple of hours (and I have no way of knowing how many hours it had

been in use before I started on it), the plastic area above the microdrives became very hot indeed "A slight increase in warmth above the microdrives is normal, and should not be cause for alarm," the manual reassures. Sure enough, the microdrives continued to work happily, even in their tropical environment, so I guess recourse to cooling devices like the famous 'frozen long-life milk carton' (my only significant contribution to ZX lore) will not be necessary.

You'll see that colour generated by the QL is crisp and clear on a monitor, and significantly better on a TV than that produced by the Spectrum. Even stippled areas and lines did not show the 'dot crawl' which became a trademark of Spectrum graphics. You also have much more control of the screen than with the Spectrum. The QL allows you to specify the colour (or colours) of the border, and its width. Windows can be created with Lisa-like things happening apparently independently in different areas of the screen at the same time.

Having read the specifications, I thought the QL would run about 35 per cent faster in BASIC than the Spectrum, but it did not seem significantly quicker to me when doing such things as running through loops and printing on the screen. I did not have long enough with the QL (time was strictly rationed for review purposes) to write any moving graphics games in BASIC, to see how such a program compared with its Spectrum counterpart, but I suggest that similar programs will run faster on the QL if you make use of SuperBASIC and don't force the machine to accept such degrading statements as GOTO.



Although a membrane sits underneath it, the QL's 'real keyboard' offers a distinct improvement on the old Sinclair membrane keyboards.

# COMPUTER BARGAINS AT MAGRATHS!

**MAGRATH'S  
PRODUCT  
OF THE  
MONTH!**

## KEYBOARDS TRS-80 WITHOUT CONNECTOR

**TYPE F HJL  
TYPE O  
HJL  
WITH CONNECTOR**

**FANTASTIC BUYS AT \$143<sup>75</sup> each**

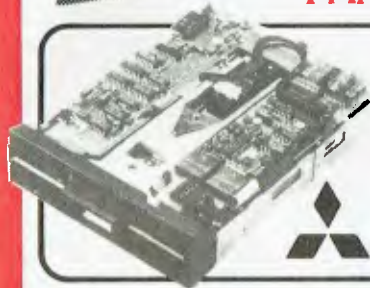

### DISC DRIVE CONNECTORS

FOR 8" DRIVES **\$1.27** POWER CONN. FOR 5.25" DRIVES **\$1.04** POWER CONN.

### MITSUBISHI DISC DRIVES

M4851 (5.25")	\$299.00	500K 48 TPI, SLIM, DSDD
M4853 (5.25")	\$350.00	1.0 MEG. 80 TPI, SLIM, DSDD
M4854 (5.25")	\$362.25	1.6 MEG. 96 TPI, SLIM, DSDD
M2896-63 (8")	\$603.75	1.6 MEG. 96 TPI, SLIM, DSDD

## SHUTTLE 300T DATA MODEM



**VALUE!  
\$266<sup>00</sup>**

### GENERAL DESCRIPTION

The Shuttle 300 is a direct connect modem, providing full duplex operation, up to 300 Baud, via the RS-232C Port of a Terminal or Personal Computer.

The Shuttle 300 is a basic modem, relying on a telephone for dialling and answering calls. However it does provide the full 12V bipolar output signals required by RS-232C for reliable operation with computers and terminals. The RS-232 connector also provides "Carrier detect" and "clear to send" outputs and uses "Data Terminal ready" and "request to send". Three front panel led's provide visible indication of carrier detect, receive data and transmit data status, while a fourth led is used as a power on indicator.

The "Voice/Data" switch allows selection of telephone or modem operation. An "Answering/Origin" switch allows either answer or originate mode of operation.

Power for the Shuttle 300 is provided by an internal power supply which conforms to Telecom Australia regulations.

### NEW FROM NASHUA!



**5.25" TWIN PACKS \$11.44 each**  
MD-1 SS/SD, MD-1D SS/DD,  
MD-2D DS/DD.

### GREAT RANGE!!

#### COMPUTER CONSUMABLES

NASHUA (10 Discs per box) With Hub Ring	Inc. Tax
MD-1 5.25" Single Side/Single Density	\$41.60
MD-1D 5.25" Single Side/Double Density	\$48.00
MD-2D 5.25" Double Side/Double Density	\$55.30
MD-2F 5.25" Double Side/Quad Density	\$63.40
FD-1 8" Single Side/Single Density	\$48.91
FD-1D 8" Single Side/Double Density	\$56.12
FD-2D 8" Double Side/Double Density	\$61.58

#### ACCESSORIES

Library Box 5.25" - Holds 10 Discs	\$ 8.86
Library Box 8" - Holds 10 Discs	\$11.51
Storage Box 5.25" - With Lock - Holds 100 Discs	\$44.85
C20 Data Cassette (Blank) 20 Minutes	\$ 1.73

Diskette Mailer 8" - Holds up to 4 Discs	\$18.86
Diskette Mailer 5.25" (Holds up to 4 Discs)	\$12.65
Data Batch Case (up to 1.25" of Printout)	\$17.25
Print Wheel Album (Holds 6 Printwheels)	\$19.55

#### PRINTWHEELS

Printwheels - Qume Compatible - Courier 12	\$14.09
Printwheels - Qume Compatible - Light Italic 12	\$14.09
Box of 6 Printwheels - As Above	\$74.38

#### RIBBONS

OKI-ML80	\$ 5.41
OKI-ML82A	\$ 5.41
OKI-ML83A	\$ 5.41
OKI-ML84	\$ 7.39
BMC-BX80	\$12.65
TI-855, TI-850	\$15.00
Qume - Sprint 11	\$15.53

**VALUE  
\$1210.95**

## EPSON HX-20 PORTABLE COMPUTER FROM MAGRATHS

The HX-20 portable computer package—you get a computer, a printer and a display unit—all in one, go anywhere, self-contained system.

### LOOK AT THE FEATURES:

- FULL FUNCTION PORTABLE COMPUTER—NOT A CALCULATOR • STANDARD 16 KB RAM EXPANDS UP TO 32 K BYTES OR THE 32 KB ROM MEMORY TO 72 KB • ABLE TO COMMUNICATE • FULL SIZE ASCII KEYBOARD • BUILT-IN PRINTER • LCD SCREEN • MUSIC GENERATION VIA PIEZO—ELECTRIC SPEAKER • MICROSOFT BASIC • TIME AND DATE FUNCTIONS.

For fixed location use you can also add on the following options—display controller for monitoring on large screens (even your home TV), floppy disk drive for expanded memory, and acoustic coupler for two-way information transfer.

### SPECIFICATIONS:

Peripheral Interfaces	Bar Code Reader	Special Connector
External Cassette		Standard audio cassette interface.
System Bus		16-bit address bus; 8-bit data bus and control lines
ROM Cartridge/Microcassette Interface		40 pin connector.
Power Supply		1 10 port with 3 input, 6 output lines.
		NiCd batteries; internal; Sub C type; 1200mAH capacity; 40 hour capacity running BASIC (less depending on use of RS-232C port, printer or optional microcassette).
Recharge		Full charge within 8 hours.
Physical Characteristics		29.0x21.5x4.4cm (11.4"x8.5"x1.7").
Size		Approx. 1.7kg (3lbs 13oz).
Weight		
Options		8KB RAM plus 24 KB ROM or 16 KB RAM plus 16 KB ROM.
Expansion Unit		Total expansion is 32 KB.
Microcassette		Uses standard micro cassette tapes.
ROM Cartridge		Uses 8, 16 or 32 KB to load program into RAM.

MC/MAG/114



**MAGRATHS ELECTRONICS, 55 A'BECKETT STREET, MELBOURNE, 3000.**

Phone: (03) 437 1122. Telex AA31001. Phone or Mail.

**MAGRATHS ELECTRONICS, SHOP 5, 59 BARRY PARADE, BRISBANE, 4006.**

Phone (07) 832 3944. Phone or Mail.

SCHOOLS, GOVERNMENT DEPARTMENTS AND INDUSTRY CUSTOMERS PLEASE PHONE FOR TAX FREE PRICES AND BULK ORDER.

Mail or phone orders add \$3.00 up to 1 kg pack/post. Special rates for heavy items on request. MAIL/BANKCARD ORDERS ACCEPTED.

**ALL ITEMS INCLUDE S/TAX UNLESS STATED OTHERWISE.**

## Sinclair QL

The computer comes with the power supply, the lead to connect a television or monitor, four software packs (which we will look at shortly), four blank microdrives, the 'free gift' RS232 lead, and a massive manual, twice as big (and heavy) as the QL itself. The looseleaf manual is an enormous improvement on manuals previously provided with Sinclair products, and shows that Sinclair (probably under prompting from Psion) has at last recognised the virtual impossibility of giving people too much information about the product they are buying.

The manual is divided into eight major sections ('Beginner's Guide', 'Keywords', 'Concepts', 'QL Quill', 'QL Abacus', 'QL Archive', 'QL Easel' and 'QL Information'). The sections on Quill, Abacus, Archive and Easel contain comprehensive instructions for running the software. As I said earlier, the computer itself was not even finalised when I reviewed it, so it is not surprising that the manual was not yet in its final state. Proofs of the manual were expected within three days. It's obvious Sinclair believes in miracles, has extremely swift printers, or didn't intend that those who got the first machines would get complete manuals.

Reading the manuals shows many areas where the designers of SuperBASIC have been very clever. For example, SuperBASIC incorporates an action called 'coercion'. If the QL is expecting a string, and you give it a number, it will automatically turn it into a string. Similarly, if you try to add two numbers, and one of them is in the form of a string, it will convert the string to its numerical equivalent (in effect, VAL the string) rather than crash with an error message. This means the QL needs to know when you are dealing with strings, and when you mean numbers; so it uses the plus sign (+) for adding numbers and the ampersand (&) for adding strings. The following are valid in SuperBASIC:

```
LET A = "3" + 4 (sets A equal to 7)
```

```
LET A$ = 6 & "32" (sets A$ to "632")
```

The use of LET, as in nearly every BASIC in the world except the first three Sinclair BASICs, is optional.

The designers of SuperBASIC have developed a number of other ways to produce a better language for you. If

you ask the QL to print a variable which has not been assigned, it does not respond by crashing (as the other Sinclair machines did) or by assigning the value 0 (or the empty string) to this unknown variable (as many BASICs do). Instead, the QL prints an asterisk, as a sign that you have requested an undefined variable. If you fail to specify a NEXT command it will continue to process quite happily, but will ignore the FOR which does not have a NEXT.

These things, of course, were on the review machine. As Sinclair was working on SuperBASIC up to, and beyond, the last moment, things may well be different by the time you get your QL. Some commands given in the provisional manual do not work, and some of the sample programs (in any BASIC) could not work. (One such program which tries out the various colour combinations includes a vertical line in some places where it needs a comma, uses STEP as a FOR/NEXT variable, as in FOR step = 0 TO 3, and has a remarkably haphazard line-numbering sequence; I imagine it was included in the provisional manual as some sort of obscure joke).

Those who decried the faint 'beep' on the Spectrum will be pleased to hear the QL gives out a very healthy tone, much louder than that produced by the BBC Micro. The SCROLL command (which is not related to SCROLL on the ZX81) is followed by two numbers. The scrolling can be positive or negative, and single display line (that is, pixel) scrolling is possible.

The QL has a real-time clock (accessed as DATE\$) which is set to a random time and date on switch-on. Despite the claims in the manual that DATE\$ could be manipulated like any other string in Sinclair BASIC (that is, it could be broken into sections by slicing), I found the only effect of a slice was to change the time set on the clock, rather than to extract a section of it. PRINT DATE\$(0), for example, set the time part of DATE\$ (it has both date and a 24-hour digital clock) to 00:00:00; and PRINT DATE\$(18) TO 0, which I thought would print out the seconds part of the time, simply set the time to 00:00:18.

Sinclair Research later told me that DATE\$ could be modified using a command called SDATE. This



A tiny microdrive cartridge being inserted into the built-in microdrives.

command was not in the documentation available to me. I was also told that slicing was only possible after another string had been assigned to DATE\$.

### The Bundled Software

The QL comes with four software packs supplied on microdrive: a word processor (Quill), a spreadsheet calculator (Abacus), an 'intelligent' database (Archive) and one to produce business graphics such as bar charts (Easel).

When you first read the instructions given in the manual for using the four programs, your heart will probably sink. The instructions go on, and on. How could you ever make sense of those instructions, you think, in order to run the software? Fortunately, with at least one of them (Quill), it is not really necessary to understand very much in order to be able to start making use of the program.

I suspect that for many non-business owners of the QL, Quill will be the most popular program of the four. While many of us have little need to draw bar charts of such things as our steadily increasing personal wealth, all of us tend to write letters, school essays or reports – and Quill is almost ideal for this. I'll explain the 'almost' shortly, but first I want to back up the claim I made that it is not necessary to understand much about the program before using it.

When you start with Quill you have a red frame on the screen, on which you are typing in green. The start of each paragraph is automatically indented, without you doing anything (or even knowing how to set indents). Above the red frame many operating

# THE IDEAL PRODUCT FOR THE OEM/DEALER MARKET

## OKI MICROLINE 80 COL MATRIX PRINTERS

For the OEM's and Dealers looking for:

- High reliability
- Long Life
- Value for money
- Good dealer margins
- Already used by the majority of manufacturers as a standard printer offering
- One of the most well established printers in Australia at every level of commerce and industry.

**Then Microline  
is the answer!**

**MICROLINE is the biggest selling printer in the USA.**

### FEATURES

Speed  
Centronics  
RS232  
N LQ Mode  
Graphics  
Short Line Seeking  
Head Life  
Bottom and Rear Feed  
Full 96 ASCII Character Set  
Paper Tear Bar  
Tractor Feed

### ML 82

120 cps  
Yes  
Yes  
No  
Yes  
Yes  
Yes  
200 million characters  
Yes  
Yes  
Yes  
Option

### ML 92

160 cps  
Yes  
Yes  
Yes  
Yes  
Yes  
200 million characters  
Yes  
Yes  
Yes  
Option

**Compare the features — then get with the strength. MICROLINE FROM DATRON**

For further information or the name of your nearest Datron Distributor, contact:

**DATRON** Pty. Ltd.

79-81 Regent Street,  
Redfern 2016  
New South Wales  
Telephone: (02) 698 8211  
(02) 699 4824

#### Distributors

NSW	— AWA — Terminals Division	(02) 887 7111
VIC	— AWA — Terminals Division	(03) 529 4133
QLD	— QM Industries	(07) 393 1977
WA	— Multi-System Sales	(09) 444 0376
	— AWA — Terminals Division	(09) 321 9334

#### Also Available From:

NSW	— BDS Computers	(02) 437 4122
	— Computer Enterprises	(02) 419 8577
	— Tab EDP Systems Pty Ltd	(02) 427 5533
Newcastle	— Focus Systems	(049) 69 6355
Armidale	— Logo	(067) 725 1144
VIC	— BDS Computers	(03) 690 1222
	— TAB EDP Systems Pty Ltd	(03) 579 0011
	— Microskill	(03) 699 2000
	— Namrac	(03) 890 1770
TAS	— Management Technology	(002) 34 4522

## Sinclair QL

instructions are printed, such as the one telling you to press function key four to change the typeface. You do not need to worry about a word being split at the end of a line, as the QL automatically starts a new line when needed, and spaces out the words on the line you've just completed so that the right and left-hand margins both form straight lines. This happens without you needing to know anything.

The system responds rapidly to typing. There is no appreciable delay when typing in on 'clean paper' (that is, a bit of the screen which does not already have words on it). If, however, you wish to 'overwrite', the system slows down to an annoying extent. Despite this, the program really does live up to the claim that it can be used without reading the manual. Function key one is permanently assigned to 'help', so pressing it leads you into a series of sections designed to get you out of trouble (even if 'help' has to be loaded in from the microdrive). Once you exit the help mode, you'll find yourself exactly where you were before you called for help, so you can continue from that point.

There are five kinds of typeface available with this program: normal (the standard QL high-res character set), bold (which comes out white, rather than green, as you type), high (which produces superscripts with funny squashed descenders on such letters as 'g' and 'j'), low (subscripts) and underline. They can be mixed, so 'bold, underlined, high script' would be a valid mixture. (You can also have 'underlined, low script', but the underline goes right through the middle of the letters).

### Conclusions

You're going to like the QL. Like all Sinclair products, it will probably have some annoying quirks which are not immediately obvious, and the slow access times of the microdrives may irritate some – but overall it is a fascinating package.

The QL is a computer which will encourage dabbling. There seems so much to discover about it; you'll have fun playing with it for weeks before you even feel the need to write programs of your own. You can start programming it like a Spectrum, and then gradually introduce elements of SuperBASIC to your work, so your

programming style evolves.

The colours are bright and clear and the multiple-colour, multiple-width border and windows will get a lot of exposure in coming games packages. The character set is filled with asterisks (once you move away from the standard ASCII numbers and letters), but no information was available with the review machine on how easy it would be to redefine all those extra characters.

Despite its flashiness, the QL is an unproven machine; the microdrives are unproven mass storage devices. I suggest it would be a brave businessman who entrusts his essential data to microdrives, given their current uncertainty. A comment I heard at the press launch was that the microdrives could prove the QL's Achilles heel. Having no cassette port means you are forced to use the microdrives, or lash out for external 'real' disks. Of course, I have only seen prototype machines in action, but all three I saw exhibited significant loading difficulties. I was, for example, unable to see Easel as no copy we had of the program would boot up. I imagine, however, that production machines will prove more reliable (and, certainly, I have never had problems with microdrives on the Spectrum, so there is no reason to assume the QL drives will prove less reliable).

Although I feel a great deal of goodwill towards Sinclair Research, and despite the fact that I know I'm going to spend many hundreds of hours playing with the QL in the coming months, it is hard to imagine it being adopted as a 'business machine' (which appears to be Sinclair's fond hope) by any but the smallest of companies. It makes a great home machine, and there is no doubt that many of the 750,000 Spectrum owners will aspire to the QL when it comes time to upgrade. There is a slightly tacky feel to the machine, and I would hesitate to recommend it to someone who could be buying a BBC micro (admittedly without mass storage, and without software packs) for the same price.

The enormous memory (128K) means some fantastic adventure programs are going to be written for the machine; and once the likes of Artic and Quicksilver get their teeth into the QL, software which surpasses even the best of the Spectrum

catalogue will be available.

So, I end up with a mixed conclusion. The QL is certain to be a commercial success. Hundreds of thousands of them will be sold by the end of the year. Some brilliant software will be written. Lots of people will have lots of fun with the machine ... and yet I sense that the time for foisting an unproven product on the marketplace has gone. You would not dream of buying a record player or a video recorder for \$700, if the product was surrounded by any uncertainty whatsoever. Yet that is what Sinclair lovers – like me – will probably do with the QL. We will put up with its idiosyncrasies, curse Clive from time to time, and generally have a high old time while doing so – but we won't attempt to run a business with it.

The QL may have been announced six months too soon to try and get the people at the BBC (British Broadcasting Corporation, in this case) to turn their favoured glance away from Acorn. The QL has, predictably, stretched the definition of '28 days' beyond the recognition of mortal man. Those at the 'leading edge of technology' might be laying themselves open to sacrifice upon it, but there is no doubt that following Uncle Clive and making use of the products of his Mensa mind is an enjoyable activity on its own.

Guy Kewney once said that Sinclair Research was more of a religion than a company. And so it appears to be. There is some excitement in participating in the Sinclair game, which does not accompany such stick-in-the-muds as Commodore and Acorn. Any readers of this magazine who are already committed Sinclair users will probably dismiss any doubts I might have raised and rush out willy-nilly to buy a QL and start hacking – as soon as it becomes available in Australia, which, according to Sinclair's distributors, Barson Computers, will be early in 1985. You can contact Barson Computers for more information at 86-88 Nicholson St, Abbotsford 3067. (03) 419-3033.

---

*Tim Hartnell is the Australian founder of Interface Publications, a London-based specialist computer publishing company, and has himself written many books on popular micros, including earlier Sinclair models.* □



# TODAY'S BEST BOOKS!

from  
**CBS HOLT-SAUNDERS**  
and the  
**UNIVERSITY CO-OP BOOKSHOPS**



### COMPUTE!'s First Book of Commodore 64 Games

Packed full of games: "Snake Escape", "Oil Tycoon", "Laser Gunner", "Zuider Zee", and many more. Machine language games requiring fast hands and a good eye, as well as strategy games which will exercise your mind. An excellent introduction for 64 owners who want to begin writing games.

\$22.95



### COMPUTE!'s Second Book of Commodore 64

There's something for almost any Commodore 64 user in this book: arcade and text adventure games in both BASIC and machine language, a commercial software quality word processor, a program which adds 41 new commands to BASIC, an electronic spreadsheet, and tutorials about programming sound and graphics.

\$22.95



### COMPUTE!'s Third Book Of Atari

*Third Book Of Atari* continues the COMPUTE! tradition of useful information written in a clear, understandable style. Contains games, a word processor, the Wedge (which adds new commands to Atari BASIC), a line renumbering utility, a machine language sort program, a complete character set reference table, and more.

\$22.95



### Commodore 64 Programs for the Home

A translation of the best-selling *BASIC Computer Programs for the Home* into Commodore 64 BASIC. Contains over 40 programs ideal for saving time and work in home-related chores — managing finances, arranging schedules, organizing daily routines, and more.

\$27.95

Also available

**TI BASIC Computer Programs for the Home**  
\$26.50



### "Fast Reference Guides" to: WordStar® VisiCalc® CP/M® SuperCalc® Using dBase II Programming dBase II

Complete, concise, easy-to-use summaries of all of the commands, options, menus and syntaxes for the most popular software packages.

\$5.95 each



### COMPUTE!'s Guide To Extended BASIC Home Applications On The TI-99/4A

TI owners who want to put their computers to work will appreciate the many useful programs: sorting routine, checkbook adder, data manager, spreadsheet program, electronic card file, appointment calendar, and more. Don't miss out!

\$22.95

#### INSPECT THESE AT YOUR CLOSEST BRANCH

• TECHNICAL BRANCH 831 GEORGE STREET, SYDNEY PHONE: 211 0561 • 80 BAY STREET, BROADWAY, N.S.W. PHONE: 212 2211 • NSW INSTITUTE OF TECHNOLOGY  
• NSW UNIVERSITY • SYDNEY UNIVERSITY • ANU CANBERRA • WOLLONGONG UNI. • CANBERRA CAE • MACQUARIE UNI. RYDE • ARMIDALE UNI. (U.N.E.) •  
NEWCASTLE TECH. • NEWCASTLE UNI. • RIVERINA CAE (Wagga Wagga) • MITCHELL CAE (Bathurst) • GRIFFITH UNI. (Qld.) • GIPPSLAND IAE (Vic.) •

#### AVAILABLE BY MAIL ORDER!

Yes, send me your complete Software Price List and the following Books/Software

\$  
\$  
Less 5% discount if Co-Op member \$  
Add postage: \$3.25 N.S.W. \$4.75 elsewhere. \$  
Cheque Postal Order enclosed \$  
or Bankcard No.

Send to:  
UNI Co-op Mail-Order P.O. Box 54 BROADWAY, NSW. 2007  
Place me on your free mailing list for 12 months

NAME  
ADDRESS  
STATE P.CODE  
SIGNATURE  
Expiry CO-OP MEMBERSHIP NO

# Smart!

# Esprit 6310

FROM

Mitsui Computer



**The new generation in Smart, low-cost terminals from Mitsui:**

- Ergonomic styling and design
- 14" high-resolution screen
- 22 programmable, non-volatile function keys
- 7 emulations
- Smart – includes line drawing graphics and smooth scroll.



**STOP  
PRESS**

# THE BIG NEWS ON SMALL PRINTERS FROM BROTHER

INTRODUCING  
THE NEW BROTHER COMPACT  
DOT MATRIX PRINTER M-1009

brother M1009

## **M1009. Big on features. Small on cost.**

Here is a new compact printer with features you would only expect in more expensive machines. Like a 9 pin dot matrix printing head with a 20 million-stroke service life, crisp 50cps bidirectional logic seeking printing for normal characters, unidirectional printing for super and subscripts and graphs, plus low noise operation.

The M1009 incorporates 96 ASCII type characters with 63 graphic sets and international characters and Centronics parallel interface. Printout is on cut-sheet paper or, optionally, fanfold and roll paper.

All this for only \$299!

## **HR-15. Letter quality printouts for under \$799**

A compact, letter quality printer, the HR-15 offers features which give it a quality and versatility unmatched for the price; interchangeable letter quality daisy wheel; optional electronic keyboard, tractor feeder and auto cut-sheet feeder; proportional spacing; colour print; 3K buffer memory; Centronics parallel or RS232C interface and many more.

## **HR-5. The world's most compact printer.**

This is the smallest, most versatile, fully functional heat transfer thermal printer available. At only \$249, it is fully portable (battery or mains operation) and so small that it will easily fit into your briefcase. The HR-5 is the only printer in its class able to offer the choice of thermal or plain paper and its other features include: full graphics function; roll paper feed; Centronics parallel or RS-232C interface; silent operation; variable printout; 30cps printout.

# brother®

**Affordable  
Electronic Printers  
Brother Industries Ltd.,  
Nagoya, Japan.**

**Brother Industries (Aust.) Pty. Limited,  
7-9 Khartoum Road, North Ryde,  
N.S.W. 2113.**

Sydney (02) 887 4344. Melbourne (03) 873 3655.  
Brisbane (07) 52 5257. Adelaide (08) 42 6373.  
Perth (09) 478 1955.

All prices are recommended retail and include sales tax.  
They may be slightly higher in W.A.

CSO-1304

# THE GREAT DATABASE SEARCH

## — WIN A DATABASE PROGRAM!

### *The Prize: KnowledgeMan KPaint KGraph*

#### **The Prize**

As you'll have seen from our review, KnowledgeMan is a powerful database package containing many of the features on the average dBase II user's 'wish list'. It runs on most computers using PC-DOS, MS-DOS or CP/M-86, with a minimum RAM of 192K and two 500K disk drives. In fact, most of KnowledgeMan's limitations come from the machine on which it is run, not the program's own innate limits; as our reviewer said, its specifications are "enough to make a dBase user drool".

KPaint integrates with KnowledgeMan to automate the process of screen and form design. Using KPaint you can set up your forms with a variety of special effects (your terminal permitting), including different screen colours, blinking fields, reverse video, invisible entry (which prevents data from being displayed as it is input) and warning bells on specified fields.

KGraph allows the production of high-resolution colour graphics with KnowledgeMan; you don't even need to exit from the spreadsheet to produce a graph. KGraph can produce bar graphs (clustered, stacked and three-dimensional), scatter diagrams, line graphs, area plots, pie charts and high-low-close graphs. It also enables the user to draw free-form diagrams, and symbols, logos or pictograms can be incorporated into the graphics. Split-screen graphing is supported, with up to four graphs appearing simultaneously on a single screen.

These three modules are all being presented to the winner by Database Management Services, Suite 6, 83 Gler Eira Rd, Ripponlea 3183, with the aim of inspiring creative interest in the wide use of database management programs, be it in business, education or simply for fun.

Closing date for entries is October 31, 1984; entries received within seven days of that date will be accepted if postmarked on or before October 31, 1984.

You read the excellent review of KnowledgeMan in the August issue of *Your Computer* — now you can win a copy of this database management program for your own use, plus two additional modules to help you use it to its fullest extent: KPaint and KGraph. The value of this prize is over \$1000.

To win this great prize, you have to put your creative mind to work. We want to hear about your ideas for an interesting and innovative use for a database management program. It needn't necessarily be a serious business application; as long your idea is both novel and useful, we're interested in hearing about it.

When you've worked out your database application, write an outline of its use and purpose, clearly set out in, say, a one-or-two-page document, and send it to us. Our panel of judges, which includes Matt Whelan, former Managing Editor of this magazine and chief arbiter in the Great Database Search, and a member of staff of Micro Data Base Systems, the company providing the prize for this competition, will evaluate all the entries and pick the most innovative and interesting application as the winner.

The competition will run in *Your Computer* for two months, September and October 1984, and we'll announce the name of the winner and the nature of the winning application in our January 1985 issue. The winner will be notified as soon as the judges make their decision.

Please fill in the attached coupon and send it with your entry to: **Your Computer 'Database Applications Competition', PO Box 227, Waterloo NSW 2017.**

#### **Rules**

1. All entries must be accompanied by an original entry form from *Your Computer*. The form must be signed as a declaration that the submission is the original work of the person submitting it to the competition.
2. The judges' decision is final, and no correspondence will be entered into over the competition, nor any interviews granted.

3. No employees or relatives of the Federal Publishing Co Pty Ltd, Eastern Suburbs Newspapers Pty Ltd, or Micro Data Base Systems Inc are eligible to enter.
4. The prizes in the competition have no monetary refund value, are not transferable, and cannot be substituted or varied.
5. Any omission to consider any entry and/or error by the judges or any representative of Micro Data Base Systems Inc or the Federal Publishing Co Pty Ltd shall not invalidate the competition or give rise to any rights in any competitor to take proceedings against either of the promoters of the competition or any officers or employees of either of these companies at law or in equity on any account.
6. All competitors taking part agree as a condition of entry to accept the judges' decision as final and binding.

### ENTRY FORM

### DATABASE APPLICATIONS COMPETITION

Name: .....

Address: .....

..... Postcode: .....

I declare that the attached submission is original and has been written by me. Signature: .....

Please complete this entry form and send it to:  
**Your Computer 'Database Applications Competition',  
PO Box 227, Waterloo NSW 2017.**

# **HARD DISK MICRO DECISIONS: MD11** **THE RIGHT SYSTEM TO GROW WITH, FEASIBLY**

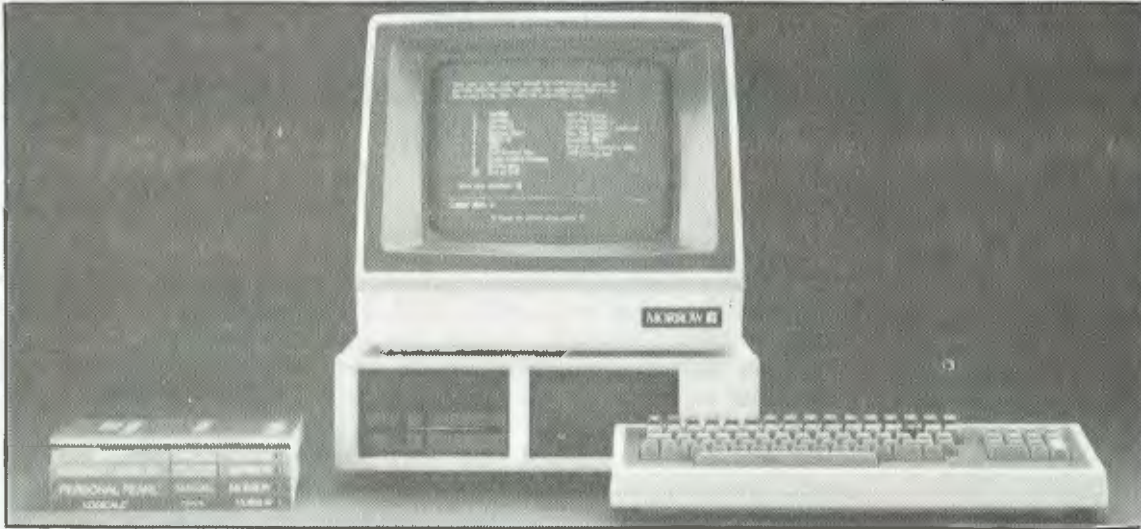

## **SOFTWARE SPECIFICATIONS**

CP/M Plus (3.0) Operating System.  
CP/M is compatible with the widest range of microcomputer business application programs available on the market today.

"NEW WORD" WORD PROCESSOR.  
"CORRECT-IT" SPELLING CHECKER.

"SUPERCALC" SPREAD SHEET.  
PERSONAL PEARL.

QUEST BOOKKEEPER II.

MICROSOFT BASIC 80: Industry standard version of BASIC.

PILOT: An elementary programming language used for creating games and other educational applications.

FUNCTION KEY PROGRAM.

SEE: YOUR COMPUTER JULY 84 FOR MD-11 REVIEW. EXCELLENT SPEED, SUPERB VALUE FOR MONEY.

*The Micro Decision model MD11 is a complete hard disk computer system at an affordable price. That 11 megabytes of storage capacity lets you access all your files from the keyboard without having to shuffle and search through floppy disks. It provides all the hardware and software needed by an independent businessman and professional who appreciates speed and convenience of a hard disk.*

*The MD11 offers a carefully selected group of business application software including word processing, forecasting, data base management and accounting functions — the MD11 speeds you through them all, even if you've never used a computer before.*

*The Micro Decision's straightforward component design insures continued reliability.*



**JUST RELEASED**  
**MORROW**   
**MD3 PORTABLE**

**PHONE FOR A DEMONSTRATION**

**AUTOMATION STATHAM Pty Ltd**

47 BIRCH STREET BANKSTOWN  
N.S.W. 2200. (02)709-4144  
TLXAA 73316

A FULL SERVICE MORROW DISTRIBUTOR SINCE 1976



# Visual 1050

By John Nicholls  
and Jeff Richards

THE VISUAL 1050 arrived in three large boxes. Why three? The usual arrangement is one for the monitor and one for the disk drive and processing unit. The third, about the same size and weight as the other two, revealed a large stack of manuals, some diskettes and the usual litter of customer agreements, warranty information and return-paid cards.

At first we were intimidated by the size and number of the manuals, but a closer inspection revealed that things were not as bad as they seemed. The bulkiest manuals were for the operating system and software: CP/M Plus (264 pages), WordStar 3.3 (590 pages), Multiplan (470 pages), DR Graph (178 pages) and CBASIC (184 pages). Fortunately, there was also a User's Guide of only 160 pages, which covered in great detail how to set up the system and get it going. All the manuals are nicely typeset, ring-bound, and housed in slip-cases about the same height as IBM's but much thicker. They all suffer, unfortunately, from inadequate indexes.

The manuals were surprisingly lacking in technical specifications, an omission I later realised was as a result of a deliberate policy. This system is "designed to serve as your professional assistant" and if it does this job properly, why should you worry what its clock speed is?

The technical specifications are in fact fairly standard. The 1050 has a Z80 microprocessor running at 4 MHz

*Is the world really ready for yet another single-user Z80-based CP/M computer? If it's cheaper than the competition and does the job just a little better, then the small business world will welcome it. The 1050, recently released by Visual Technology Inc and distributed in Australia by Kenelec, seems to meet both these requirements, and deserves to make a name for itself as a general-purpose small business computer.*

for the system and a 6502 for controlling the video display. There are 128 Kbytes of user RAM and 32 Kbytes of video RAM, plus a monitor in ROM. The high-resolution monochrome screen displays 25 lines of 80 characters and supports graphics. There is a 93-key keyboard with special function keys, and one serial port and one Centronics parallel port for attaching peripherals. Internally, there are two expansion ports and a hard-disk controller for an optional external drive.

It's a common statement in the computer industry that anything that is actually on the market is out-of-date; the new state-of-the-art model will be coming out next week or the one after or ... The Visual 1050 is an evolutionary rather than a revolutionary design, but where it shines is in the way it has taken the best design concepts and put them all together in a tradesman-like manner. Don't look for anything radically new, but you can expect to see fewer of the mistakes that plague most other

computers, including those coming from the largest and most experienced manufacturers.

The diskette drives take up the front of the system unit, and each has a capacity of 400K. The top of the unit has a recess built into it to take a tilt and swivel pedestal base for the monitor. This simple device is a snap to fit and adjust. Why can't other companies do this?

The 30 cm screen monitor has a pilot light and the usual brightness and contrast adjustments recessed below the screen. It comes with an anti-reflection faceplate and a feature that turns off the display after some minutes without keyboard input. This is a feature we liked, although we decided to set it to a rather shorter delay period of three minutes.

The screen display is green phosphor and is extremely sharp and stable, as would be expected from a manufacturer whose main product is graphics terminals. The display is controlled by its own microprocessor working with 32K of RAM and, as

## Visual 1050

well as a 25-line by 80-character display, it supports graphics of 300 by 640 pixels. Characters can be emphasised, underlined or flashing, and multiple fonts and international character sets are included.

Graphics functions include pixel on/off/invert, markers, lines, circles and arcs. Screen pixels can be PEEKed and POKEd using screen command codes – there is no direct access to the screen RAM from programs. The screen also features options for style of cursor and smooth or jumpy scrolling.

The back of the system unit has an on/off switch and a circuit breaker. Nowhere could we find reference on the machine or in the manuals about the circumstances under which the circuit breaker should be used. Also at the back are four connectors labeled parallel, serial, Winchester and monitor cable. The system set-up instructions include this statement: "Connect the Monitor Unit to the System Unit with the Monitor Cable. Note that the two plugs which terminate the cable can fit into their matching jacks in only one way".

While this is true, it would help to add that the connectors at each end are identical – to anyone not familiar with computers this is not immediately obvious – so it doesn't matter which way round you have the cable. As we shall see later, the provision of a Winchester port for the addition of a Winchester hard disk drive would add greatly to the ease-of-use of the system (at a much higher cost, of course).

The keyboard is commendably flat (4 cm max; home keys about 3 cm). The basic layout is similar to the IBM Selectric typewriter, augmented by 17(!) function keys along the top, and a combined cursor control/numeric keypad on the right, as in the unfortunate design introduced on the IBM-PC. (May the designer of the IBM keypad rot for saddling us with this infamous 'feature'). At least Visual has provided an indicator light to show when the Num Lock is selected.

On the front of all the function keys Visual has added a plain-English name showing what feature is invoked when using WordStar. In addition, the special keys for cursor

control are labelled to indicate their WordStar function. Thus DelWd will delete a word, and F11/Move will move a marked block. All the normal WordStar commands can also be invoked in the customary way (↑T and ↑KV in our examples). The beauty of this arrangement is that someone familiar with WordStar's control features can use this system without any relearning, while someone new to WordStar can use the dedicated keys without having to learn complicated control codes.

This is a well-thought-out and well-implemented scheme. The 'save and resume' function (F1) even goes further than WordStar by returning you to the previous cursor position (as in Wordstar by using ↑KS and ↑QP). The quick reference card provided by Visual generally shows only the usage of the dedicated keys rather than the WordStar codes; again this is a sensible choice – if you know the codes you'll use them; if you don't you're more likely to use the dedicated keys.

### Invisible Operating System

CP/M Plus (also known as CP/M-80 Version 3) is the supplied operating system. It is a significant improvement over version 2.2, mainly in its ability to use the second bank of 64K of RAM for extra buffers and program storage. It also features an extensive help system, improved utilities and faster operation.

It is in the way the operating system has been installed, and the way it integrates with the supplied software, which makes the 1050 stand out from a number of similar machines.

The most noticeable feature of the 1050 is a system supervisor program called Utility Manager. When the machine is turned on and a disk inserted, the Utility Manager starts itself up and displays eight options in boxes at the bottom of the screen. These options include running a standard application, running an optional application, formatting and copying disks, and displaying and altering system status.

(Actually, when we first started up the system, all we got was "disk read error", and A> prompt and then nothing. Eventually we discovered that if you typed MENU the eight boxes appeared as they were supposed to.)

Selecting one of the options using the special function keys displays a sub-menu with further options. If the user wants to run the word processor, for instance, he is instructed to insert the appropriate disk, press one more

key, and the word processor is up and running. If the option is a utility, the user is guided through the task with a series of questions and checks. It is quite possible for a typical business user to do anything he needs to with this machine and never see the CP/M 'A>' prompt at all.

The Utility Manager makes it very easy for the novice user to get started on useful tasks with the machine as soon as it is unpacked, and it certainly makes shopfront demonstrations very impressive. However, the experienced user may find it gets in the way somewhat – it occupies disk room and it makes some activities rather slow. To cater for the experienced user, there is a function in the Utility Manager that turns it off and allows the machine to revert to standard old CP/M with its complex command lines, low disk overhead and good speed.

The Utility Manager uses the CP/M SUBMIT facility, so optional applications which are patched into the appropriate menu choices do not have to be modified in order to take full advantage of its features. When optional applications are patched into the menu the Manager can be instructed to ask for additional options or a command line 'tail', so if your accounting package needs a password in order to start up, the Utility Manager can cater for it.

Entering a 'set up system' menu from this first screen starts you on a set of menus which allows you to configure the system just the way you want it. For example, you can select slow or fast scrolling, three different designs of cursor (triangle, rectangle, underline) with or without blinking, and whether the keyboard will 'click' or not when you enter a character.

One of the options on the main menu is 'RUN STD APPLIC' (run standard application), and this is the one you'd use most often. Selecting this option leads you to another menu listing the programs supplied with the Visual 1050 (WordStar, Multiplan, DR Graph and CBASIC). With a floppy disk system you will then be prompted to insert the appropriate disk, so a fair amount of disk-swapping and menu selection goes on before you get into your application. However, this arrangement really shines on a hard-disk system where all your programs are on the hard disk: you just select your application and away you go.

For a newcomer, the system works well on a floppy-based system

# YOUR COMPUTER/CASIO Lucky Subs Draw Card

Here's an exciting new offer which applies until November 30, 1984: if you take out a new subscription to *Your Computer*, or renew your existing subscription, you could win an exciting Casio Personal Computer valued at \$99.95! Until the end of November 1984, all subscription cards we receive each month will be put into a barrel, and THREE lucky subscribers each month will win an exciting Casio PB-100 Personal Computer valued at \$99.95. That's right, a total of twelve PB-100s to be won!

But that's not all. At the end of November, all the subscription cards received during the four-month period will be placed back in the barrel, and a grand prizewinner drawn. This lucky subscriber will win the incredibly powerful Casio PB-700 Personal Computer System, complete with FA-10 four-colour printer/plotter and CM-1 microcassette tape recorder – a prize worth over \$1000!

So NOW is the time to send in your subscription – do it today, to make sure of your chance to win a Casio computer! Simply fill in the card opposite, and send it either with a cheque or money order, or with your American Express or Bankcard number filled in. Either way, don't forget to sign it.

Winners will be notified by telephone or telegram after each drawing of the winning subscription cards from the barrel.

Don't run the risk of missing out on *your* copy of Australia's leading computer magazine, *Your Computer*. Take out a subscription NOW, to make sure you get it reliably every month.

It's more convenient, too: your copy will come straight to your mailbox, saving you a special trip to pick one up. And that's not all, you'll actually be saving money: we're currently offering a 12-issue subscription for only \$24 (posted within Australia). That's only \$2 per issue – you save \$6 over the year compared with buying it over the counter.



**Casio PB-100 Personal Computer** ▶

**Subscribe now!**  
— Offer ends in November.

## Casio PB-700 Personal Computer System



## Australia's leading computer magazine!

**Subscribe NOW to  
*Your Computer* and you  
could win one of twelve  
powerful Casio Personal  
Computers – or a complete  
system worth over \$1000!**

NSW Lottery Permit No. TC84/1349.  
Victorian Lottery Permit No. 84/470.

A powerful pocket-sized personal computer which makes an ideal learning machine for beginners. It features a 12-character dot matrix LCD screen, easy programming in standard BASIC language, and a full range of scientific functions and commands. It handles programs with up to 544 steps (up to 1568 steps with optional plug-in RAM pack), and both positive and negative numbers from 10 to the power of minus 99 up to 9.99999999 times 10 to the 99th! The PB-100 runs for over 360 hours on its two inbuilt lithium cells, and comes complete with a comprehensive, easy-to-follow 196-page 'Learn As You Go' manual. Normal recommended retail price \$99.95!

At the heart of this system is the powerful Casio PB-700 Personal Computer, 'big brother' of the PB-100. This provides all the features of the smaller machine PLUS a much bigger LCD screen with four lines of 20 characters. The display can also handle graphics, with 160 by 32 pixel resolution. The PB-700 also features a much bigger program memory: 4 Kbytes come built in, with optional expansion up to 16K!

Along with the PB-700 itself, our grand prizewinner will get *both* the matching Casio FA-10 four-colour printer/plotter and the Casio CM-1 microcassette recorder. These provide the PB-700 with all the facilities to generate multi-colour 'hard copy' for both text and graphics, and to 'save' both programs and data quickly and reliably.

Normal recommended retail price for this complete system is over \$1000!

# NOW WE'RE BETTER THAN WE'VE EVER BEEN BEFORE!

(and we were voted the best Home Computer of 1983!\*)



**NEW  
JOHN SANDS  
SEGA RELEASES!  
AVAILABLE  
NOW!**

## JOHN SANDS SEGA SC3000H

- Typewriter style, hard keyboard.
- 48K total RAM.
- 32K ROM.

- Expandable to 80K total RAM.

The SC3000H brings you high level BASIC language, high resolution graphics, 32 graphic sprites, multi-function keyboard, full screen editing, 48 single keystroke commands, 16 colors and a 3 channel 5 octave sound range. Connects to your television set and standard cassette recorder. Put simply, it's the best in its class of home computers for the whole family.

## WE'RE EDUCATING AUSTRALIA!

With your John Sands Sega SC3000H you will receive:

- A 5 hour hands-on computer course!
  - Plus a Free Sega Supertape!
- Our FREE EDUCATION COURSE will give you an extremely comprehensive "hands-on" grounding in the early facets of computer usage. It's practical learning at its best! Our FREE SEGA SUPERTAPE contains 6 great educational programs on the one great cassette.

ALL THIS FOR THE RECOMMENDED RETAIL PRICE OF ONLY \$349!

Available from leading retailers throughout Australia.

## JOHN SANDS SEGA SF7000 SUPER CONTROL STATION.

- 3 inch micro disk drive.
- 156K bytes working capacity.
- 312K bytes storage capacity.
- High Speed. Baud transfer rate 250K.
- RAM memory expansion 80K bytes total RAM.
- Centronics and RS323 interfaces.
- Extended BASIC language.



Using the latest 3 inch micro disk drive, this complete expansion system for your John Sands Sega Home Computer provides a powerful 80K of RAM. Brings great flexibility and speed at your fingertips. Allows you to interface with existing printers and many other peripherals.

John Sands  
**SEGA**<sup>®</sup>

## THE BEST OF SOFTWARE.

We have the programs to give you the very best from your John Sands Sega Home Computer. Educational series, personal business, recreational games (plus a new Joystick and Steering Wheel/Accelerator), music and many more. Many of these devised in Australia, by Australians. Not far away is LOGO too! A must for every schoolchild. For education, personal business, fun and games, settle for nothing less than the total technology home computer system from John Sands Sega.

\* Video Age voted the John Sands Sega SC3000 the Best Home Computer in 1983.

Prices, product specifications and performances are subject to change without notice.

I'd like to know more. Please send me complete literature on the John Sands Sega Total Technology Home Computer System.

My name \_\_\_\_\_

Address \_\_\_\_\_

Postcode \_\_\_\_\_

Please mail to: Marketing Department,  
John Sands Electronics,  
6 Bay Street, Port Melbourne, Victoria, 3207.  
(Telephone: (03) 645 3333)

because you don't have to make each disk self-loading by copying the system files to it. This is what causes new users a lot of worry, because the procedure seems long and complicated right at the start. (It is even worse if the disks are copy-protected, so you are forced to modify software that has cost a lot of money). Once you've gained more experience, Visual shows you how to make the disks self-loading, so with floppies you can by-pass the menu steps.

One feature of the operation of the Visual 1050 is that when there is any operation which takes an appreciable time to complete (such as formatting a disk) a message always appears on the screen to indicate something is happening – another friendly idea that other manufacturers could emulate.

### Good Software Package

The standard software supplied with the Visual 1050 makes an attractive package for small business use. There is WordStar 3.3 (the latest version), with MailMerge for word processing, Multiplan for spreadsheets, and DR Graph for charts and diagrams. CBASIC is also supplied, as well as a terminal emulation utility and a number of other system maintenance utilities.

WordStar is so well-known that it hardly needs mention. It is extremely well integrated with Visual 1050, as explained above. The addition of the special keys for all WordStar commands does away with what we think is the only valid criticism of this word processor.

We struck one area of confusion at the beginning, which may be familiar. Trying to file the first WordStar file, we struck the message DISK FULL with a newly formatted, unused disk. The solution turned out to be easy (once we found it). WordStar, Multiplan and DR Graph all file to Drive A:, where the program disk is. To use the second drive (B:) for data, you have to prefix each file name with B: or change drives each time a program is started. No computer user should have to put up with this. To make it worse, this information is in the manual in an Introduction, where you can easily miss it.

Multiplan is similar to several other spreadsheets – not that there is much that can be different among the various implementations. Again, the keyboard is automatically reconfigured to suit – the HELP key and the cursor control keys do precisely what is expected. Multiplan does have the

useful ability to relate several worksheets together, a feature which enables complex calculations to be broken down into simpler, smaller, tasks. It also supports a variety of output formats – a facility that is put to good use in integrating it with the graphics package.

The third software package is DR Graph, and this is the package that lifts the 1050 above the standard of many other similarly priced CP/M machines. DR Graph works in conjunction with the GSX graphics interface to permit the user to produce bar, line and pie charts with full headings, labels and scales through a simple, menu-driven set of procedures. In addition, data for the charts can be taken directly from data files generated by Multiplan.

A simple series of steps, fully detailed in the manual, involves writing the output of the spreadsheet to a special file, jumping out of Multiplan into DR Graph, and reading rows or columns of the spreadsheet file into the graph. Other graph parameters, such as headings, labels and axes, are not disturbed by the new data, and the new graph can be displayed immediately.

Even if the data to be graphed is entered manually, the procedure is very simple. Once a format for the graph has been established, new data and headings can be quickly entered, making updating of charts on a regular basis very straightforward. When the graph is complete it can be sent to an attached printer or plotter. The currently supported graphing devices include the Epson MX80 printer, and plotters from Hewlett-Packard and Houston Instruments. The device drivers are separate files, so if your plotter manufacturer can supply a suitable driver it is a few minutes' work to make it compatible with DR Graph.

Charts can be bar, line or pie. Bar and line graphs can have up to 20 data sets plotted per chart, and can be oriented either horizontally or vertically. Labelling options include character size and one of four fonts. In addition, colour codes can be nominated for the various elements of the graph. The use of different colours has no effect on the monochrome display, but the colour will be displayed on a printer or plotter that supports the colour option.

The graphing package is a particularly



# ANZ computer books

Australia & New Zealand Book Co. Pty. Ltd.

Your first source of information

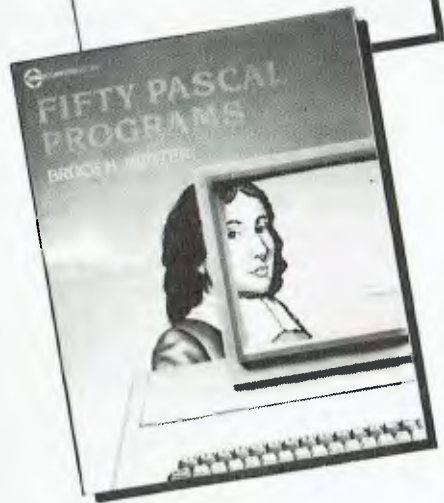
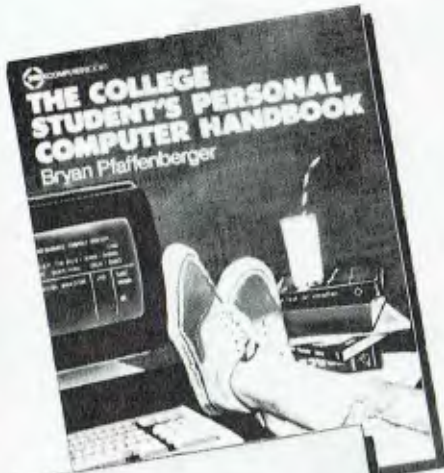

## BRAINTEASERS FOR THE COMMODORE 64

(PHOENIX) (PB) \$19.50

A collection of programs to puzzle and amuse, worthy of the 'Brainteasers' and worthy of the computers for which they are designed. All of the programs will exploit the graphic capabilities of the machine and many contain an IQ rating at the end of the program.

## COLLEGE STUDENT'S PERSONAL COMPUTER HANDBOOK

(SYBEX) (PB) \$26.95

This friendly guide will aid students in selecting a computer system for managing information in a college course, and writing research papers. Many anecdotes and personal examples make it fun to read. A buying guide to hardware and software is also included.

## CP/M PLUS HANDBOOK (SYBEX) (PB) \$28.95

This guide is easy for the beginner to understand, yet contains information for advanced users of CP/M Plus (Version 3). Built-in and transient commands and the file-transfer and system editor operations are described in detail along with many practical hints for using a CP/M Plus computer.

## FIFTY PASCAL PROGRAMS (SYBEX) (PB) \$35.95

More than just a collection of useful programs. Structured programming techniques are emphasized and concepts such as data type creation and array manipulation are clearly illustrated. Business, engineering, financial and personal applications are included.

## SIMPLY dBASE II (DILITHIUM) (PB) \$17.95

A simple, easy-to-follow guide that shows how to get going with this database management program. It explains what you do, how you do it, and why you do it.

These books are available at bookstores and computer stores everywhere but if you experience difficulty you wish to receive regular information on new books, contact the distributor, **ANZ BOOK CO.**, 10 Aqueduct Frenchs Forest 2086. (02) 452-4411.



PICTURE D  
PICTURE D  
PICTURE D  
PICTURE D



10 detailed images  
paint, print, or p  
PAINTPIC or P  
PUZZLEPIC



One of ten  
Space Images



You make  
this picture!

powerful piece of software. It is easy to use, and a novice can get usable charts the first time he or she starts it up. The range of options means that extremely complex charts and diagrams could be constructed by the experienced user. It runs quickly, and is extremely tolerant of user errors. The combination of good screen graphics and good software to drive it makes the Visual 1050 a very attractive machine.

The final software package supplied is CBASIC. This could be used for program development, although it is not particularly suitable for beginner programmers. Its main use would be to enable the business user to run some of the business packages written in CBASIC. In addition, there is a terminal emulation utility which permits the 1050 to access other computers and time-share systems. It supports ASCII data transfers only, so if you wanted to access programs on Remote CP/M you would have to find a copy of MODEM7 or YAM.

Incidentally, the 1050 will automatically recognise and adjust to disks in several different formats, so transferring software will be no problem. Formats mentioned are Kaypro II and DEC Rainbow, though the manual implies there may also be other formats.

### In Summary

In use, the machine is as smooth and simple as its external appearance implies. The user interface through the Utility Manager is consistent and logical, and those determined to press on into the system without consulting the manuals can do so with little trouble. As additional questions or queries arise, a quick return to the Utility Manager will reveal an option that does the job. For instance, when one ham-fisted typist decided the keyboard auto-repeat was too sensitive, a few minutes' investigation revealed the option to disable it.

The Visual 1050 is manufactured in the US by Visual Technology, a manufacturer of graphics display terminals. Visual Tech products have been distributed in Australia by Kenelec for six years, and there is a national network of service centres. This will be the first computer Kenelec has distributed, but the similarity between small computers and display terminals is such that technical service should be no problem. Kenelec will be appointing distributors to look after packaging the Visual 1050 with a printer and business software, and support for the business user will be through his

### SPECIFICATIONS AND REPORT CARD

Unit:	Visual 1050
Made by:	Visual Technology Inc, Massachusetts USA
Processor:	Z80A at 4 MHz
RAM:	128 kilobytes
Storage:	Dual slimline 13 cm floppies, 400K each
Features:	Battery-backed real-time clock, built-in hard disk interface
I/O:	RS232 serial, Centronics parallel
Operating system:	CP/M Plus
Languages supplied:	CBASIC, Assembler
Software supplied:	WordStar with MailMerge, Multiplan, DR Graph, Terminal Emulator
Keyboard:	93 keys, 17 function keys, numeric/cursor pad, fully configurable
Display:	25 lines by 80 characters, green
Graphics:	Bit-mapped, 640 by 300 pixels, 6502 processor with 32K of RAM
Expansion:	Two internal slots
Options:	5M hard disk, sync/async communications card, extra RAM to 256K

Ratings:	Excellent	Very Good	Good	Poor
Documentation:		•		
Ease of use:	•			
Functionality:		•		
Value for money:	•			

Price:	\$3445 incl tax.
Review unit from:	Kenelec (Aust) Pty Ltd, 48 Henderson Rd, Clayton 3168. (03) 560 1011.

or her local dealer.

The only criticism we could find of the software was there is sometimes confusion about whether an instruction about pressing a key refers to a numeric key or a special function key. For example, the Utility Manager uses special function keys 1 to 8, while DR Graph uses numeric keys 0 to 9. Similarly, in some applications, the number keys on the numeric keypad perform different functions to the number keys on the main keyboard. Both these problems involve an adjustment that would be easy with a little practice.

As far as the hardware is concerned, there are three small points of criticism. The Centronics connector at the rear of the machine lacks the usual spring-loaded clips to seat the connector firmly home. In addition, the plastic lid of the system unit bends alarmingly if you place the screen on top and then lean on it, but it seems quite adequate if treated

with normal respect. And thirdly, I would like to see a centimetre or so trimmed off the reset button, to eliminate the possibility of an unintentional reset when you push the machine back against a wall.

These small quibbles aside, the Visual 1050 is a very attractive machine. There may be other small computers with colour displays or larger disk storage or more memory, but you get what you pay for, and the Visual 1050 is very good value for money. The combination of hardware and software is well-suited to typical business applications, and the excellent user interface and comprehensive documentation make it easy for new users to get started. A small-business person who knows nothing about computers, except that they should make the job easier, will find the Visual 1050 fills the requirements nicely; with the hard disk option it should be an even better performer.

A YEAR or two ago one of the many misguided pundits in this business claimed that computer technology would eventually displace books as a communication medium. He had obviously never tried to set up a printer or get an operating system to work using the manuals provided! Further proof of his error is the growing proportion of bookshop shelf space devoted to computer books. Many of these books are of doubtful value, although there are exceptional publishers (like Sybex) who can be relied on for quality.

Almost all the BBC books I have read so far come from the UK, but there are some local ones around. Books on the Beeb seem to come in three categories: books of listings, school textbooks (mainly about 'computer awareness', whatever that is) and books with 'real' information in them (nitty gritty stuff about how to make your Beeb really know who's boss).

### A Byte of the Beeb

Others, of course, don't fit these categories; for example, Geoff Wheelwright's *Companion to the BBC Micro* (published by Pan), is a lightweight collection of information about the Beeb, best read before purchasing a machine because it would be nearly irrelevant after doing so. In its 128 pages the author outlines the history of the machine's development, describes its interior, possible uses (including a good comparison of View and Wordwise, but not Edword) and alternative storage devices. It is padded with 20 pages of appendices, including the slowest screen dump routine I've ever used, a line editor (so that you can experience the joys of using a mainframe, perhaps?), and a LOGO simulator which is most unworthy of the name. Some books are written to be digested: this one is strictly for a between-meal snack.

Considering the outrageous mark-ups on imported software at this end of the world, games fans are faced with organising their own imports (easy to do

with international plastic money) or going broke. An alternative is *Sixty Programs for the BBC Micro*, also from Pan Books (priced around \$14). This is great value for games players who can type well. All the old favourites are there in one form or another, and if you can't afford commercial software, this would be an excellent book to boost your collection of programs. It also has the advantage that you can put the software on disk, modify it and so on without having to cope with some of the arcane protection systems on most cassette software.

### Getting it Together for Assembly

For those who have BASIC pretty well under control, the joys (?) of writing in assembly language often beckon. The 'User Guide' introduction to using assembly language is fine, if you're good at using assembly language. Having failed that chapter miserably, I invested in Richard Freeman's *Beyond BASIC*



(published by the BBC, priced around \$20). Well designed and bound, it introduces the Beeb's 6502 built-in assembler in ten units, taking the reader through the essentials of hex and binary, past addition and subtraction, to jumps, loops and branches before tackling the 6502's addressing modes. The second half covers the use of the stack, the operating system and lists. A final chapter shows how to put your knowledge to work in speeding up BASIC programs, such as in sorting strings using assembler sections and other techniques that would have scared me silly not long ago.

Throughout the book I had the impression that the author hasn't seen himself or his readers as superhuman: he points out (I suspect from personal experience) where mistakes are likely to occur and passes on simple, useful advice where

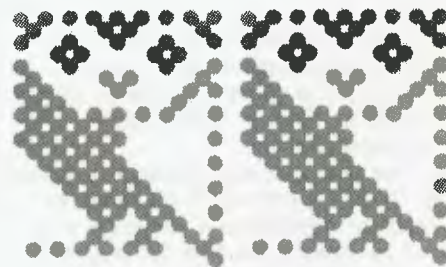

it is needed. I couldn't find any errors in the book, and would put it high on a list of purchase priorities.

### BASIC II

BASIC II was released last year and if, like me, you purchased a Beeb more than 12 months ago you probably possess BASIC I. You can check by pressing BREAK, then typing REPORT and pressing RETURN. If you get "(c) Acorn 1981", BASIC I is installed; "(c) Acorn 1982" indicates you are the proud owner of BASIC II. According to Acorn there isn't much difference between the two versions, and to disprove it Barsons sent everyone a page of small print in the August 1983 'Acorn Update' detailing 27 differences.

Some of these differences seem trivial, some are not. I had a terrible time trying to make sense of the @% facility for keeping numbers under control in one program. It worked perfectly on my machine, yet kept printing 7.69999999 instead of 7.7 on machines with BASIC II. The solution was to set @% = decimal 2314 (hex &90A) at the start of a program, and it worked on both versions. I'd recommend its use as a matter of course in any program destined for distribution to a user group.

A welcome addition is the OSCLI command, which takes a string and passes it directly to the command line interpreter. In BASIC I it is necessary to use a routine like the one listed in this column last July. Another nice touch is the OPENUP command for read/write files.

BASIC's built-in assembler has been enhanced in useful ways with four EQUIVALENCE pseudo-ops, including EQUUS which allows you to place strings in or around machine code with the greatest of ease.

Most of the other differences relate to the destruction of BASIC I's bugs, including that infamous pair, ON ERROR GOTO 9999 and INSTR("xy","xyz"). I wonder if they'll ever get around to fixing that most common bug of all, 'syntax error'? □

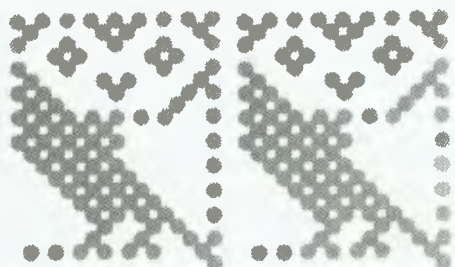

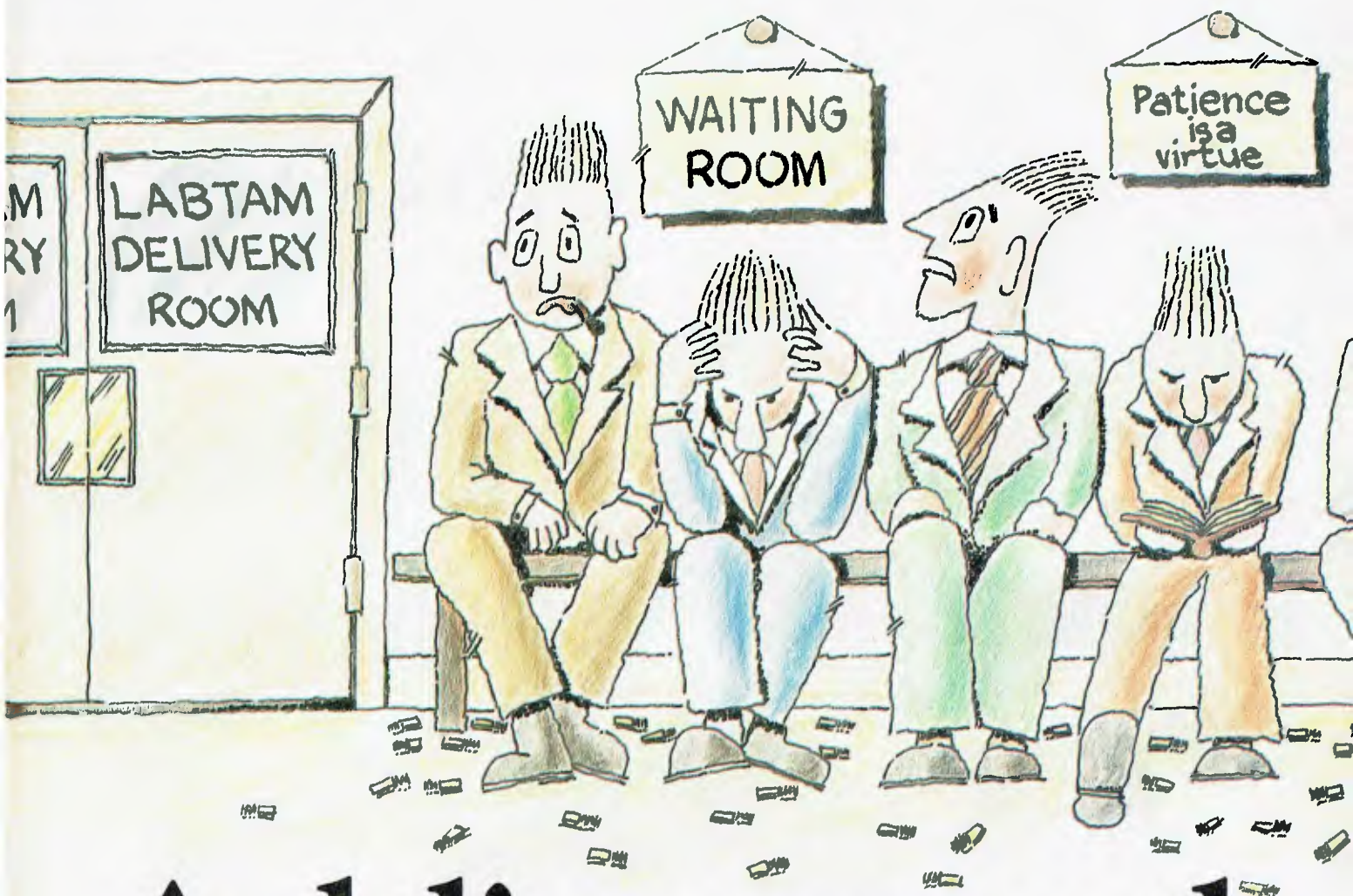

# A delivery worth waiting for.

It's like this all the time; anxious company executives waiting for their custom built baby. Our reply is always the same, "To fit within your requirements and be a time and money saver, waiting 30 days for delivery is worth it".

Labtam will nurture and care for your new investment showing you how to make it grow and expand, ready for your future needs.

The Labtam Series 3000 Computer is an affordable, high performance computer built specially for real world processing applications to protect your investment in both hardware and software.

For further information contact:  
 VICTORIA, HEAD OFFICE, 43 Malcolm Road,  
 Braeside, Australia, 3195. Telephone: (03) 587 1444.

SYDNEY, Ground Floor, 2 Help Street, Chatswood,  
 N.S.W. 2067. Telephone: (02) 411 2588.



**Leading the Field.**



Graf-X D.A.G. L1391.

# The computer system that won't give you any arguments at home.



**CPC 464**  
complete  
with  
monitor  
and  
datacorder

It's eight in the evening. The weekly soap is about to start on the box. And you're in the middle of a program.

Either way, there's going to be trouble.

The new CPC464 gets round the problem very neatly.

It comes complete with its own colour monitor or green screen VDU. Yet it costs around half the price of a comparable home micro system.

That's not all. As well as the monitor, the CPC464 includes a built-in cassette data recorder, 64K of RAM (42K available), 32K of ROM, typewriter style keyboard and a very fast extended BASIC.

And it comes complete and ready-to-go. Just plug it in.

**High resolution graphics.  
Stereo sound.**

The quality of the graphics on the CPC464 screen beats the micro/domestic TV combination out of sight.

That's because our monitor drives each colour on the screen directly from the computer. Nothing gets in the way of the best possible picture. And you won't have tuning problems.

It sounds good, too. Especially when you feed the 3-voice, 7-octave stereo output through a hi-fi amplifier and speakers.

**64K RAM.**

With 64K of RAM there's plenty of room for sophisticated and complex programs.

Over 42K is available to users, thanks to the implementation of ROM overlay techniques.



Dollar for dollar, other micros simply can't match the CPC464's memory.

**Amsoft.  
Exciting software range.**

Arcade games, educational programs and business applications are all designed to utilise the CPC464's impressive graphics, sound and processing abilities.

A rapidly expanding range of programs is already available. High quality software that takes advantage of the CPC464's high specification and speed-loading capability. Which means even complex programs can be loaded quickly.



**Amstrad. User  
Information Service.**

Whether you're interested in serious commercial applications or you're a games fanatic you'll want to receive the latest information about your AMSTRAD Computer. Upon request you will be advised about the latest software and its application, special information concerning your CPC464, available peripherals and software reviews. There will also be programs and exercises to try.

**User Clubs.**

In addition to the User Information Service you will be given details of where you may contact your nearest independent user club.

**Green screen VDU.**

Perfect for data management with

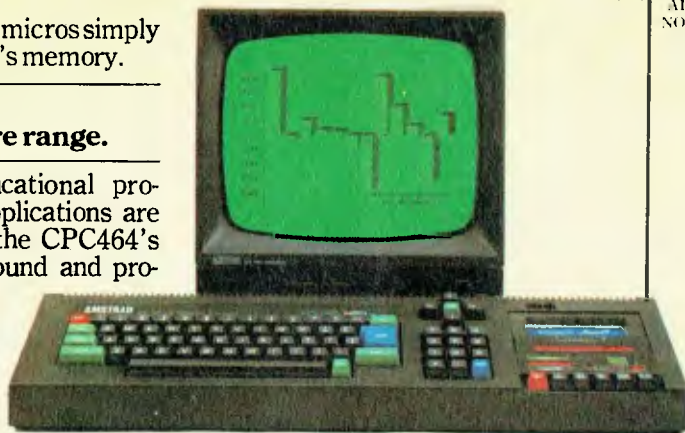

CPC464 green screen VDU (GT64)

high resolution screen, 80 column text display and up to 8 text windows.

An optional power supply and modulator (MP-1) is available for use with a colour TV.

**CPC464.  
Unlimited scope for expansion.**

We're with you all the way. That's why there's a built-in parallel printer interface. A low cost optional disk drive system including CP/M\* and LOGO. A joystick port. And the virtually unlimited potential of the Z80 data bus with sideways ROM support.



Optional disk drive DDI-1 including interface CP/M\* and LOGO



Optional 80 column dot matrix printer DMP-1. Offers high performance computerised text processing

Distributed and guaranteed throughout Australia by:

**AWA-THORN AMSTRAD**

\*Trade mark Digital Research  
I'd like to know more about the incredible CPC464 complete computer system and where to see one.  
Please send literature right away.

NAME

ADDRESS

POSTCODE

To: AWA-THORN Consumer Products Pty. Ltd.,  
348 Victoria Road, Rydalmere, N.S.W. 2116.



CODE NO. TFB186

# Here's the answer to your Customer service & Retail Business problems...

The 'Breeze' Retail Computer Software Package will blow away the nagging, everyday problems that confront every retailer.

The 'Breeze' turns a cash register into a gold mine. Providing all the normal cash register functions together with vital accounts and management information and reporting features — right at your very fingertips:



- Fast Efficient Cash Sales
  - C.O.D. Sales
  - Lay-by Sales Records
  - Magnetic Credit Card Facility
  - Bar Code Reader Capability
  - Sales Person Commission Records
  - Accounts with Immediate Customer Invoice
  - Preparation of Monthly Statements
  - Sales Tax Payable and Claimable
  - Preparation of Banking Slips
  - Sales Analysis
  - Debtors Aged Balances
  - Stock Control
  - Inter Computer Communication Facilities
- and much more.

Your business future is now at the end of your fingertips.

## Open your door for a Breeze

It's a breath of fresh air.



Breeze Software (Aust.) Pty. Ltd.  
 First Floor, 39 Gheringhap Street, P.O. Box 1220,  
 Geelong, Vic., Australia 3220. Phone (052) 21 6144

Please send more information on the "Breeze Retail Computer Software"

Name .....  
 Title .....  
 Company .....  
 Address .....

P/Code .....

W00037158S/AM

ASSEMBLY language is often regarded as too difficult for the casual programmer, and besides, why do something the hard way when BASIC is available?

But there are some tasks that are well suited to assembly language, and, provided the job is not too large or complex, assembly language can be a fast and interesting way to solve a problem. This month I will present a problem with the Kaypro that can be solved with a simple assembly language program, and show the procedures needed to implement it.

On start-up the Kaypro monitor initialises the serial port to 300 baud. The CONFIG program permits you to tell the system whether or not the printer is attached to the serial port, but it does not permit you to set the baud rate of that port automatically. If you use the serial port for the printer, you must either run the printer at 300 baud or run BAUD each time you reset the machine. Wouldn't it be handy if a little program that set the baud rate would run automatically each time the computer was started?

**A Suitable Case For ...**

Such a program is a candidate for assembly language. It will be simple and small. Though the task could theoretically be done from BASIC, the effort would not be justified. It turns out that the whole assembly language program consists of just six lines, and occupies a single disk block.

To set the desired baud rate we have to write a value into the special output port that controls the baud rate. On the Kaypro this port is port 0, so the instruction would be 'OUT 0'. This command sends the contents of CPU register A to the nominated output port, so obviously before we execute this instruction we have to get the required value into register A. The command to load a value into a register is 'MVI reg,data' (MVI stands for 'move immediately'). Let's assume the value to be sent to the output port is 6. The instruction sequence becomes

```
MVI A,6
OUT 0
```

Simple! We could end the program at this point, but let's make it a little fancier by printing a message on the screen. To do this we will use one of the most powerful tools available to the assembly language programmer – the operating system call.

**An Operating System Call**

The operating system call is a technique by which certain procedures supplied within the operating system can be used by programs. The program loads information into the CPU registers and then jumps into the operating system. The operating system uses the information in the registers to decide what job it has been requested to do, and possibly to decide what data it has to work on. When it completes the job it might load some new data into the registers, and return control to the calling program.

CP/M supports a large number of operating system calls, many of them involving quite complex tasks. We will use a relatively simple one, called 'print string', which simply sends a sequence of characters to the screen. To advise the operating system we want to print a string we load the number 9 into register C. This 9 is simply an arbitrary number that was selected to identify the 'print string' command when CP/M was first written. The command therefore is "MVI C,9".

**A Pseudo Op?**

We also have to tell the system what data is to be printed. To do this we have to know something about a type of assembly language instruction called a 'pseudo op'. This is actually a command to the assembler program – it controls the assembly activity rather than being an instruction within the program. The pseudo-op we need for this task is DB, which stands for 'definite byte'. The assembler will handle this pseudo-op by inserting into the program, at the location indicated, the characters following the DB command. In this case it will be the string we wish to have printed.

Having arranged for the character string to be included in the program, we need to advise the operating system of the address of this string. The easiest way to do this is to assign a label to the DB pseudo-op, and use this label to refer to the address of the beginning of the string. It would be possible to work out the physical memory location of the string, but it is much easier to use labels and let the assembly program look after the actual physical addresses. The label will be MSG and it will end with a colon, so the assembler won't try to interpret it as an instruction. Note we will have to locate the string in the program, so it is out of the way of the executable instructions – we don't want our program trying

to 'execute' the print string. Right at the end is a convenient spot for it.

The string will start with an ASCII 26, as this is the character required to clear the screen. Next will come the actual message. The string will finish with an ASCII 36, which is the dollar symbol. This symbol tells the operating system when the end of the string has been reached. Again, it is an arbitrary character decided on by the writers of CP/M in order to keep things as simple as possible. So the line defining the message is:

```
MSG: DB 26,'Baud Rate set to 1200$'
```

To let the operating system know where we have stored the string, we load the address of its first character into register pair DE. The label MSG holds the address of the start of the string, so the command is 'LXI D,MSG' (LXI stands for 'load extended immediate' – that is, extending a 16-bit load into a register pair).

**COMPUTER CASSETTE DUPLICATING**

For Commodore® and Commodore® Fast Loading Systems, Microbee®, Spectrum® and Most Formats.

We offer a precision duplicating service with Guaranteed Results and on-site testing with Top Security.

Note: We do not pirate other people's software. Proof of Ownership or owner's approval will need to be presented with all duplicating orders.

Blank Computer Cassettes wound to any length with your own label or ours.

**QANTEM**

Audio Electric Pty. Ltd.  
38B Scotsburn Ave.,  
South Oakleigh  
Melb. Ph (03) 544 7301

**The Big Jump**

Finally, we jump into the operating system. This is done with a jump to the subroutine at address 5, or 'CALL 5'. The operating system will perform the print string function, using the address of the data we have given it, and return to our program. To finish the program we simply need an instruction to take us back to the CP/M prompt. There are a number of ways this could be done, but the easiest is simply a 'return-from-subroutine', or 'RET'. This works because the operating system loaded our program in the first place, so it looked like a simple subroutine - we don't have to worry about how this was achieved, we only have to know that a return instruction takes us back to the CP/M prompt.

One last task is needed. We have to tell the assembler the physical memory location at which the program will be loaded and run. CP/M programs always load into location 100h, and there is no reason not to run this program at this address. The command to achieve this

(which must go right at the beginning) is:

ORG 100h

**Naming the Masterpiece**

All that is now required is to give the program a name, and assemble and run it. Let's call it SETB. The file in which it is created should be called SETB.ASM. This can be created by any word processor, but be careful to include a carriage return after the last line. Copy it to a disk that has ASM.COM and LOAD.COM on it. Type ASM SETB and LOAD SETB, and your program will be assembled and saved to disk as SETB.COM. You can run it by typing SETB, or you can patch the command SETB into the auto start-up option of the system.

The program can be formatted to improve legibility, and comments can be inserted. Constants (6, 9 and 5) can be replaced by labels, so their function is

more obvious. If you want a baud rate other than 1200, consult the reference table in the back of the handbook and select the appropriate value. Possible improvements would be to use cursor addressing commands at the beginning of the string to position the message in the middle of the screen. Note that the message could not be positioned at line 5 using this technique. Can you work out why?

SETB.ASM

-----  
ORG 100H

MVI A,6

OUT 0

MVI C,9

LXI D,MSG

CALL 5

RET

MSG: DB 26,'Baud Rate Set to 1200\$'

**When it comes to Apple & IBM compatibles . . . come to Emona**

**MicroProfessor  
MPF-III**

**Runs  
Apple IIe  
Software  
Amazing  
Value!**



**EMTEK-PC**

**16 Bit  
IBM  
Compatible  
Same price as  
an Apple IIe  
10 MB Version  
available**



**EMTEK EX-120**

**120 C.P.S.  
DOT MATRIX** **\$399\***  
ex. Tax



**ERGOVISION**

**Video  
Monitor**

**\$212\***  
ex. Tax



**Hi-resolution**

**FLOPPY DISK  
DRIVES**

**Reliable TEAC mechanism**

**\$566\***  
ex. Tax

**\$289\***  
ex. Tax



**EMONA COMPUTERS PTY LTD**

**"THE TECHNOLOGY HOUSE"**

**National Australia Bank Bldg,  
2nd Floor, 661 George St., Sydney, N.S.W.  
Ph: (02) 212 4815 or 212 3463 Tlx: 74500**

**We have dealers in all states — Call us NOW for details.**

IBM: reg. trade mark of International Business Machines Corp. Apple: reg. trade mark of Apple Computers Inc. EMTEK: reg. trade mark of Emona Computers Pty. Ltd.

\* Add 20% Sales Tax to all prices if applicable. Prices shown are for N.S.W. Additional transport charges may be involved for other states.

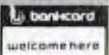

# Buy Hardware/Software at only 10% above wholesale as a Buyer's Club Member

## • Buying Power

Save hundreds of dollars when you buy computers, Peripherals, Hardware, Software, Books, Systems Furniture, Stationery & supplies at only 10% above DEALER/WHOLESALE PRICES (plus delivery).

## • Warranty

All products sold, carry a 90 days Warranty. We replace or repair any faulty item (in original condition & packing) returned to us within 90 days of the date of your invoice date.

## • Membership Satisfaction Guarantee

If you are not satisfied with our service, notify us within 30 days, to receive a 100% Money Refund.

## • Credit Card Facilities

We accept Bank Card, Master Card and Visa Card. Mail Orders & Phone Orders are welcomed. We can also arrange Leasing Contracts.

## • Free Newsletter

As a member you will receive your regular FREE user newsletter which will contain useful hints, technical tips, announcements of up-coming specials and other benefits.

Choose hardware and software from hundreds of manufacturers, including:

- |               |            |             |                  |                       |
|---------------|------------|-------------|------------------|-----------------------|
| • Altos       | • Columbia | • IBM/Comp. | • Okidata        | • Software Publishing |
| • Amdak       | • Corona   | • IUS       | • Peach Tree     | • Apple Compatible    |
| • Apparat     | • Cromemco | • Lotus     | • Princeton      | • Apple Compatible    |
| • AST         | • DEC      | • MicroPro  | • Quadram        | • Tandon              |
| • Ashton-Tate | • Digital  | • Microsoft | • Sanyo          | • Tecmar              |
| • Apple/Comp. | • Research | • Morrow    | • Sierra On-Line | • Toshiba             |
| • CDC         | • Epsom    | • Motorola  | • Visicorp       |                       |
| • Coleco      | • Hayes    | • NEC       |                  |                       |



## CONSULTECH AUSTRALIA BUYERS CLUB Business Membership Application

Yes! Please enrol us as a Member in the CONSULTECH AUSTRALIA BUYERS CLUB. The Membership will entitle us to buy Computers, Hardware, Software & Books, all at just 10% above Dealer Wholesale Prices. We will also receive all the other exclusive, money-saving services available to members. We understand that we are under no obligation to buy anything! Please check [x] all boxes that apply:

### Individual Membership

- One-Year Membership for \$ 75.00  
 Two-Year Membership for \$125.00

### Business Membership

- One-Year Membership for \$125.00  
 Two-Year Membership for \$200.00

Please bill our Credit Card:

- Bank Card  Master Card  Visa Card  
 Account No. [.....] Exp. Date [...../...../.....]

Cheque or money order enclosed for \$ [.....]

Company/Name [.....]

Address [.....]

Suburb [.....] State [.....] P/Code [.....]

Telephone BH. [.....]

[.....] AH. [.....]

Authorized Signature [.....]

OUR COMPUTER IS:

- |  |   |
|--|---|
| <input type="checkbox"/> IBM PC        | <input type="checkbox"/> Kaypro           |
| <input type="checkbox"/> Apple         | <input type="checkbox"/> IBM Compatible   |
| <input type="checkbox"/> TRS-80        | <input type="checkbox"/> Apple Compatible |
| <input type="checkbox"/> Other [.....] |   |

OUR MAIN INTERESTS ARE:

- Computers  PC-DOS  MS-DOS  CP/M  
 Software  
 Books  
 Utilities

Call Now! Join the Buyer's Club and Start Saving Today

Consultech Australia Buyer's Club  
 10 Dorothy St., E. Burwood  
 Tel: (03) 233 8273

# THE QUEENSLAND COMPUTER EXPO '84

YOUR INVITATION TO  
 THE BIGGEST COMPUTER  
 EXHIBITION IN QUEENSLAND

Computer Expo '84 is a showcase of the latest advances in microcomputers, peripherals, software and publications.

It's Queensland's major Show that gives you a better understanding of the role of Computers in Business and the home.

8-11th November  
 Crest International  
 Roma St, Brisbane.



## ULTRA RELIABILITY AT 100 CPS, WP-1000 PRINTER



- ★ Clearly formed dot matrix characters: 9x11 dots
- ★ High through-put with bi-directional/Logic seeking (66L/M)
- ★ Both Centronics and RS232c built in
- ★ Paper back-feeding by software
- ★ Fanfold paper, roll paper & cut paper
- ★ Easily detachable print head

DEALER INQUIRIES WELCOME  
 For further information contact:

**NSA** Nissei Sangyo Co Ltd  
 INCORPORATED IN JAPAN  
 200 PACIFIC HIGHWAY, CROWS NEST  
 N.S.W. 2065 AUSTRALIA  
 TELEPHONE: (02) 923-1522  
 TELEX: AA70941  
 FACSIMILE: (02) 922-2498

# Buy Hardware/Software at only 10% above wholesale as a Buyer's Club Member

## • Buying Power

Save hundreds of dollars when you buy computers, Peripherals, Hardware, Software, Books, Systems Furniture, Stationery & supplies at only 10% above DEALER/WHOLESALE PRICES (plus delivery).

## • Warranty

All products sold, carry a 90 days Warranty. We replace or repair any faulty item (in original condition & packing) returned to us within 90 days of the date of your invoice date.

## • Membership Satisfaction Guarantee

If you are not satisfied with our service, notify us within 30 days, to receive a 100% Money Refund.

## • Credit Card Facilities

We accept Bank Card, Master Card and Visa Card. Mail Orders & Phone Orders are welcomed. We can also arrange Leasing Contracts.

## • Free Newsletter

As a member you will receive your regular FREE user newsletter which will contain useful hints, technical tips, announcements of up-coming specials and other benefits.

Choose hardware and software from hundreds of manufacturers, including:

- |               |            |             |                  |                       |
|---------------|------------|-------------|------------------|-----------------------|
| • Altos       | • Columbia | • IBM/Comp. | • Okidata        | • Software Publishing |
| • Amdak       | • Corona   | • IUS       | • Peach Tree     | • Tandon              |
| • Apparat     | • Cromemco | • Lotus     | • Princeton      | • Tecmar              |
| • AST         | • DEC      | • MicroPro  | • Quadram        | • Toshiba             |
| • Ashton-Tate | • Digital  | • Microsoft | • Sanyo          | • Visicorp            |
| • Apple/Comp. | • Research | • Morrow    | • Sierra On-Line | • NEC                 |
| • CDC         | • Epsom    | • Motorola  |                  |                       |
| • Coleco      | • Hayes    | • NEC       |                  |                       |



## CONSULTECH AUSTRALIA BUYERS CLUB Business Membership Application

Yes! Please enrol us as a Member in the CONSULTECH AUSTRALIA BUYERS CLUB. The Membership will entitle us to buy Computers, Hardware, Software & Books, all at just 10% above Dealer Wholesale Prices. We will also receive all the other exclusive, money-saving services available to members. We understand that we are under no obligation to buy anything! Please check [x] all boxes that apply:

### Individual Membership

- One-Year Membership for \$ 75.00  
 Two-Year Membership for \$125.00

### Business Membership

- One-Year Membership for \$125.00  
 Two-Year Membership for \$200.00

Please bill our Credit Card:

- Bank Card  Master Card  Visa Card  
 Account No. [.....] Exp. Date [...../...../.....]

Cheque or money order enclosed for \$ [.....]

Company/Name [.....]

Address [.....]

Suburb [.....] State [.....] P/Code [.....]

Telephone BH. [.....]

[.....] AH. [.....]

Authorized Signature [.....]

OUR COMPUTER IS:

- |  |   |
|--|---|
| <input type="checkbox"/> IBM PC        | <input type="checkbox"/> Kaypro           |
| <input type="checkbox"/> Apple         | <input type="checkbox"/> IBM Compatible   |
| <input type="checkbox"/> TRS-80        | <input type="checkbox"/> Apple Compatible |
| <input type="checkbox"/> Other [.....] |   |

OUR MAIN INTERESTS ARE:

- Computers  PC-DOS  MS-DOS  CP/M  
 Software  
 Books  
 Utilities

Call Now! Join the Buyer's Club and Start Saving Today

Consultech Australia Buyer's Club  
 10 Dorothy St., E. Burwood  
 Tel: (03) 233 8273

# THE QUEENSLAND COMPUTER EXPO '84

## YOUR INVITATION TO THE BIGGEST COMPUTER EXHIBITION IN QUEENSLAND

Computer Expo '84 is a showcase of the latest advances in microcomputers, peripherals, software and publications.

It's Queensland's major Show that gives you a better understanding of the role of Computers in Business and the home.

**8-11th November**  
**Crest International**  
**Roma St, Brisbane.**



## ULTRA RELIABILITY AT 100 CPS, WP-1000 PRINTER



- ★ Clearly formed dot matrix characters: 9x11 dots
- ★ High through-put with bi-directional/Logic seeking (66L/M)
- ★ Both Centronics and RS232c built in
- ★ Paper back-feeding by software
- ★ Fanfold paper, roll paper & cut paper
- ★ Easily detachable print head

DEALER INQUIRIES WELCOME  
 For further information contact:

**NSA** Nissei Sangyo Co Ltd  
 INCORPORATED IN JAPAN  
 200 PACIFIC HIGHWAY, CROWS NEST  
 N.S.W. 2065 AUSTRALIA  
 TELEPHONE: (02) 923-1522  
 TELEX: AA70941  
 FACSIMILE: (02) 922-2498

# DIARY '84

*As the microcomputer industry grows, so do the opportunities to meet with like-minded people, to learn more at seminars, classes and exhibitions and generally to dig deeper into the wonders and bewilderingments of microcomputers.*

*We asked Horan, Wall and Walker, The Information Agency, to compile a list of some of the more interesting goings-on around the country. Here are the results of their gatherings:*

## Tuesday 16 October

### SA Electronics 84

This exhibition has been organised in conjunction with the Electronics Association of South Australia. It includes a computer show entitled SA Computer '84, which will be attended by over 40 exhibitors. Computer info at the exhibition will cover the big boys down to micros and home machines. RAHS Showgrounds, Wayville, South Australia, till October 18. (08) 212 4421. Tues 11.30 am-6.30 pm, Wed 11.30 am-8.30 pm, Thurs 9.15 am-6 pm.

## November

### Short Courses

The Continuing Education arm of the Royal Melbourne Institute of Technology offers 40 to 50 short computing courses. They begin all the time and cater for beginners right through to experts. There are no prerequisites for the courses, which range from half a day to five days in length. Topics include Choosing a Home Computer and Introduction to Unix, as well as sessions on assorted applications. Royal Melbourne Institute of Technology, 124 La Trobe St, Melbourne. (03) 660 2532. \$45 and up.

### Horses for Courses

The WEA in Sydney says November is the time to enrol for summer computing courses beginning in 1985. Two will be available, a lecture and demonstration course and one offering hands-on experience. Expect to pay around \$26 for no hands or \$50 for hands-on. The

courses last six weeks and enrolments should be made using the form on the WEA program. Programs are available at your local library. WEA House, 72 Bathurst St, Sydney. (02) 264 2781.

## Tuesday 6 November

### 11th Australian Computer Conference

One of this year's most high-powered computer conferences, which includes an exhibition under the auspices of the Commonwealth Department of Trade and Industry, takes place this month. The 11th Australian Computer Exhibition and Conference offers a chance for all the most prominent computer people to show their wares and talk about their plans. RAS Showground, Driver Avenue, Moore Park, Sydney, till November 9. (02) 331 9111. Tues, Thurs 10 am-8 pm, Wed, Fri 10 am-6 pm.

## Thursday 8 November

### Computer Expo '84

Brisbanites are in for a treat this month with "just about every brand you can think of", as the organiser said, on show at this computer fair. Here's the list: Hewlett-Packard, NEC, Commodore, Atari, MicroBee, Toshiba, President, Sony, Data General, Epson, Sigma, Wicat. Brands not represented in their own right are likely to be seen on dealers' stands set up by Brisbane computer shops. Crest International Hotel, Roma Street, Brisbane, till November 11. (07) 372 3380. Thurs-Sat 10 am-9 pm, Sun 10 am-6 pm. \$2.50.

## Sunday 18 November

### Sydney Apple Users' Club 6th Birthday Sale

Well, it's actually their annual garage sale without the garage. It's a gigantic buy, swap and sell of Apple and Apple-compatible equipment. The club secretary, Frank Revill, expects about 600 to 700 people along. A special feature of the day will be a software auction, with the emphasis on original programs. With a crowd like this it must be time to download a few old bits and pieces. Sydney Grammar School, Science House car park, College Street, Darlinghurst. (047) 36 4448. \$1.

## Tuesday 20 November

### State of the Art

Here's a seminar for advanced hackers. With the question 'Can computers really think?' becoming more and more of a poser, it looks like a good session for anyone interested in the future as well. The evening deals with fifth-generation computing and artificial intelligence. Will we eventually have computers which program themselves? You might find an answer here. Royal Melbourne Institute of Technology, 124 La Trobe St, Melbourne. (03) 660 2532. 5 pm-9.30 pm. \$45.

## Monday 26 November

### Intro to Software

Don't be put off by the grandly titled venue of this course: it's designed to appeal to those after a quick overview of software ins and outs. How's this for five days' worth? Fundamentals of computing, introduction to programming, the processor and computer number systems, BASIC programming, system software, programming using spreadsheets and seven more topics. Conducted by the Australian Computer Society. Graduate School of Management, Sydney University, Parramatta Rd, Darlinghurst. (02) 233 7677. 9 am-5 pm Mon-Fri. \$570. □

# Wordprocessing to Typesetting

Do you prepare documents for typesetting on a wordprocessor? Then you're already half way there! We typeset from your computer's floppy disk. No retyping, no mistakes. You get your job much sooner and save money too.

Call Chris Jackson or David Glover on 923 1934 for further information.

**GLOVER &  
ASSOCIATES  
DESIGN  
GROUP**

Palm Court. 8/281 Pacific Highway, North Sydney 2060

Apple // (inc E and C), Adler: Bitsy 5¼" (DOS80), Bitsy 8" (DOS80) Amtext 425 CPT 6000, 8000, 8500 Convergent Technology 8" or 5¼" Burroughs, NCR, Sigma, Prime Digital Equipment WD78 (RX01) WPS-8 (RX01) WS78 (RX01) WT78 (RX01) DECmate II-RX50 5¼" Rainbow Gestetner SX100 8" Honeywell OAS 5¼" OAS 8" SSSD or DSDD IBM Displaywriter 1 or 2D (SSSD or DSDD) Office System 6 3730 3740 8" data exchange diskette 8110 PC MS-DOS WordStar, Multimate Z/Word-34 8" (SSSD or DSDD) ICL 7700 Wordskill 8" 8800 5¼" INTERTEC Superbrain 5¼" Jacquard J100, J500 Lanier NPET (LTD-3) Remington NBI 3000/4000 levels C, F and G or 8.1 Olivetti ETS1010, TES501 8" Philips P5000 series Rank Zerox 850, 860 Ricoh TX330 Tandy TRS-80 Model 1/II/III Scripsit or Lazywriter Toshiba EW-100 Wang Archive diskette 8" OIS40/50 Archive diskette Archive diskette 5¼" Professional (PC) Wordplex Models 1, 2 WordStar and Spellbinder Standard 26 sector x 128 byte CP/M format, Data General LDC 1000 Archive 2 Datamax DEC Rainbow Heath H89 5¼" IMS8000 Intertec Kaypro MicroBee MicroMation Morrow NEC APC Otrana Osborne Pulsar 8" Sanyo MBC-1000 Sharp MZ-3500 Teletideo 802 Systel Zenith MS-DOS Wordstar IBM-PC (160K or 320K) Panasonic JB3000 8"

**File Save and File Retrieve**

When you **File Save** a worksheet 1-2-3 also remembers the cursor position, so you can make use of this if you know that when you return to the worksheet you will want to start again at a particular part. If you want to speed up the retrieve process a bit, after you have selected the file to be retrieved, you can enter some keystrokes (such as [GoTo] [F47] [Return]). These keystrokes will be stored and will be executed as soon as the worksheet is retrieved.

**How Much Memory Do You Need?**

The information published by Lotus says that to run 1-2-3 you need at least 192K, and that to run Symphony you need at least 320K. What does this mean?

With the exception of the Help file, Lotus keeps the entire program in memory at all times, as well as the whole of the worksheet. Therefore the system memory must be sufficient to take both. We'll try to give some examples, but we must emphasise that these can be used only as a *very* rough guide. The way you find out the memory available is to select 1-2-3 from the Access Menu, press any key to bring up a blank worksheet, and enter the command **Worksheet Status**. Along with global defaults, this shows the memory. After you load a worksheet you can use the same command to show what memory you now have left. To continue after this command you can press any key.

With a 576K system, loading DOS 2.0 and Lotus 1-2-3 and some other rather large files (ProKey, for example) can reduce the memory left for a worksheet to 427K. Subtracting 427 from 576 leads us to the conclusion that in this instance a 149K system would have no room for any size worksheet, and the 192K minimum system would have room for a 43K worksheet. If you already have a PC system and 1-2-3 you can do the same sort of calculation yourself; if not, and you are unsure of how much memory you'll need, we suggest you talk to your dealer, but first, how big is a 43K worksheet?

Lotus 1-2-3 can have a maximum of 256 columns and 2048 rows; Symphony expands this to 256 columns and 8192 rows. In practice, you may be able to use either the maximum number of columns or the maximum number of rows,

but not both at the same time. The limiting factor is the size of the available memory.

The upper left corner of the worksheet is always A1; the lower right corner can be found by pressing <End> followed by <Home>. These two points define the corners of a rectangle which in turn defines part of the memory requirements. Sometimes you will find that <End><Home> will take you to a blank section of the worksheet; this is because Lotus works on the furthest point of the worksheet that ever had any data in it. We'll see later how you can free the unused memory.

For every cell within the rectangle defined by <Home> and <End><Home>, except A1, Lotus takes four bytes. This is a minimum and is increased if the cell includes formulas or large numbers. If our worksheet uses the maximum of 256 columns, each row needs at least 256 by four, or 1024 bytes, which is exactly 1K. Therefore such a worksheet can use as many rows as the number of kilobytes available – in our example, 427 rows.

With each program the maximum usable memory is 640K, a limit set by the computer hardware. With this amount of memory, some sample maximum worksheet sizes are:

Rows	Columns	Program
640	256	1-2-3 and Symphony
2048	80	1-2-3 and Symphony
8192	20	Symphony only

As we said before, these are theoretical limits; using formulas and large numbers quickly uses up the memory. We examined a couple of working – I'm not prepared to call them typical – files to see what we could find. File 1 uses 32 by 186 cells (5952) and at four bytes a piece the minimum requirement is 23,808 bytes. The file actually uses 33,330 bytes, so the data takes 9522 bytes over the minimum. File 2 uses 27 by 260 cells (7020), giving a minimum of 28,080 bytes; the actual number of bytes used is 90,103, so in this instance the data takes 62,023 bytes – quite a difference!

By this stage you may be completely confused, so I'll give you my general conclusion: the figures quoted by Lotus

as minimums are just that. If you try to run the programs with less you'll find yourself running out of memory very quickly. 256K would be a more useful minimum for 1-2-3, and I have heard 512K recommended for Symphony. The simple answer is that whatever memory you have now, in time you'll want more!

To free unused memory you can't just /Range Erase or /Worksheet Delete the area no longer required. Any area that has been formatted will still remain, even if you use /File Save followed by /File Retrieve. One method that does work is this:

1. Use /Worksheet Status to show the available memory.
2. Use <End><Home> to determine the lower right corner of the worksheet.
3. Select the cell you want to be in the lower right corner.
4. Use /File Xtract Formulas to save the worksheet, with the lower right corner being the cell you selected in step 3. For safety, use a different file name.
5. /File Retrieve the worksheet you have just saved.
6. Use /Worksheet Status again to see what the available memory is now.
7. You can now /File Save Replace to file the new slimmer file over the old fat one.

**Plots For Transparencies**

Hewlett-Packard has two plotters commonly used with personal computers, the two-pen 7470A and the six-pen 7475A. Both give good results with Lotus. When plotting on ordinary paper the 7475A plots at a fast rate, which may be too fast to produce the best results on transparency paper for use on overhead projectors. For transparencies we suggest using the PrintGraph setting for the 7470A, which will plot more slowly but will give better results. Symphony uses different settings in its print drivers for paper and transparencies when using the 7475A.

**Batch Files**

IBM uses this strange term to mean a file which will run a number of commands automatically. When DOS (disk operating system) is first invoked it looks for a file called AUTOEXEC.BAT, and if such a file exists it proceeds to execute it straight away. The suffix .BAT indicates a batch file. To check whether a

# PITMAN FOR TOP COMPUTER BOOKS

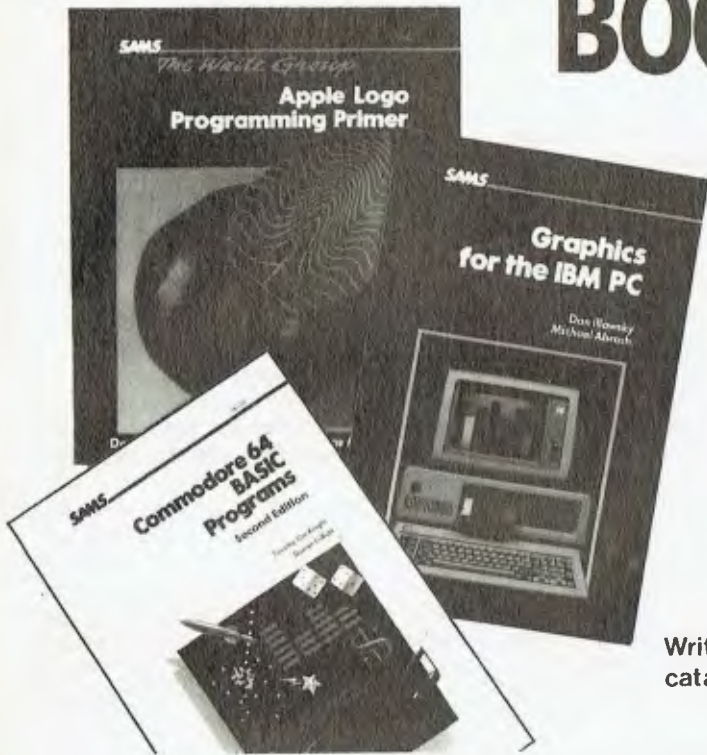

**COMMODORE 64 BASIC PROGRAMS**  
Timothy Orr Knight and Darren LaBatt

Generously illustrated collection of thoroughly documented, fun and practical programs for the powerful Commodore 64.

Book may be purchased separately.

**Book/tape \$28.95**  
**Book \$13.95**

**GRAPHICS FOR THE IBM PC**  
Dan Illowsky and Michael Abrash

Two accomplished computer game authors show you how to do animation, create business graphs, design video games, and otherwise make practical use of graphics on the IBM PC.

Book may be purchased separately.

**Book/Program Disk \$50.95**  
**Book \$21.95**

## APPLE LOGO PROGRAMMING PRIMER

Donald Martin, Stephen Prata and Marijane Axtel-Paulsen

Helps you quickly learn and use the complete LOGO language to plan and write useful and fascinating programs.

Covers recursion, outputs, utilities and features a clear concise diagrammatic explanation of LOGO syntax.

rrp \$27.95

Write to Pitman for your free catalogue

Pitman House 158 Bouverie St, Carlton Vic. 3053. (03) 347 3055 (02) 267 1477 (07) 229 5700



**Cairns means hassle-free living.**

**So does our software!**

**FOR NEC-APC, HITACHI,**

**MB16001, MB6809**

- |                         |           |
|-------------------------|-----------|
| * Video Library         | * Finance |
| * Insurance Agent       | Debtors   |
| * Insurance Broker      | Creditors |
| * Aviation Management   | Ledger    |
| * Motel Management      | Stock     |
| * Restaurant Management | Job cost  |
| * Produce buy/sell      | Payroll   |

**CYPHER RESEARCH LABS.**

**P.O. BOX 4, MACHANS BEACH 4871**

**PHONE: 55 9138**

**SAVE MONEY** | Apple II+/e users can use the diskette flip side, if another "write enable" notch is correctly made.

The **DISK NOTCHER** by **QUORUM** quickly **SOLVES** that **PROBLEM**. It's like **FREE DISKETTES!**



- Stainless Steel Guide
- Easy Leverage Handle
- Clippings Catcher
- Square Notch Cut
- Black Finish
- Get THE BEST!

**QUORUM**  
**Certifix™**

**Be Safe** | Your 'free' disk is certified error free with **CERTIFIX**. It **LOCKS OUT** flaws, yet the rest of the disk is usable. Status report displayed & saved to disk. **CERTIFIX** is convenient! It **formats** or **initializes** your disk in **genuine Apple DOS 3.3** too.

*100% Money Back Satisfaction Guarantee!*

**DISK NOTCHER** is **\$19.95**  
**CERTIFIX™** is just **\$32.95**  
**ONLY \$39.95** for **BOTH!**  
Add **\$1.50** Shipping/Per Item

**IDEAS** INTERNATIONAL Pty. Limited  
P.O. BOX 103, NORTHBRIDGE,  
N.S.W. 2063,

diskette has this file, go to the DOS prompt and type DIR/P<Enter>. This will display the first screen-load of file names. The /P in the command causes the display to PAUSE if there is more than a screen-load; pressing any key will display the next screen-load. If the file AUTOEXEC.BAT appears you can find what is in it by typing TYPE AUTOEXEC.BAT. With Lotus the original will usually read:

TIME  
DATE  
LOTUS

You can use EDLIN from DOS or a word processor to change this file. If you have an extra memory board, it is very likely that it contains a clock as well. The AUTOEXEC file can be amended to take the time from this clock and put it into the system. On AST boards this function is loaded by replacing the TIME and DATE functions with ASTCLOCK and by copying the ASTCLOCK.COM onto the disk. The AUTOEXEC file will then read:

ASTCLOCK  
LOTUS

The AUTOEXEC file will then display the current date and time and proceed to load the Lotus program.

**Symphony**

Symphony was launched at the Opera House on July 26 before a large audience. The program was on sale here ahead of schedule on 23 July. Lotus didn't waste any time getting it here, as the files are datestamped 20 June and a pamphlet listing corrections to the manual is dated 29 June. I think many people were expecting Symphony to be an expansion of 1-2-3 with a few enhancements to the worksheet, graphics and database, plus the addition of word processing and communications. This has turned out not to be the case. The changes to the 1-2-3 programs are quite extensive and while the concepts are the same, the menus are quite different; 1-2-3 users will need to retrain themselves.

Symphony appears to be easy to use. Its sheer magnitude means that it will take some learning, and it is probably best to take it one step at a time.

In view of the fact that Lotus expects many 1-2-3 users to switch to Symphony, it is strange that no mention is made in the manuals of how to load a 1-2-3 file in Symphony. Perhaps this was thought to be too elementary.

1-2-3 worksheets have the suffix .WKS, while Symphony worksheets have the suffix .WRK. When you use the File Retrieve command Symphony displays only those files with the .WRK suffix.

To find out what 1-2-3 files are on a disk you can use the File List All command, which displays the file names of all files in the current directory. To retrieve a 1-2-3 file, simply type in the name, including the extension, of the file you want. Alternatively, you could change the extensions on the disk from .WKS to .WRK by using the DOS rename command (REN \*.WKS \*.WRK)

**14 FREE PROGRAMS**

with each G-Pascal Compiler purchased on disk for the Commodore 64. \*

- DEMO - G-Pascal demonstration program.
- SUB HUNT - example arcade game (joysticks, paddles or keyboard).
- MODEM64 - data communication program.
- ADVENTURE - Pascal adventure game.
- SPRITE EDITOR - create sprite shapes easily!
- SOUND EDITOR - experiment with the synthesizer chip.
- RUNTIME - create stand-alone programs written in Pascal.
- CENTRONICS PRINT - print G-Pascal programs via parallel port.
- BITMAPPED TEXT - mix text and hi-res graphics!
- NUMBER GAME - a simple Pascal game.
- PRIME NUMBERS - calculate prime numbers quickly.
- PAINT SINGLE - 'fill in' landscapes quickly in single colour hi-res.
- PAINT MULTI - 'fill in' landscapes in multi colour hi-res graphics.
- WORD WRAP - wraps words around at the end of the line.

All of the above programs are supplied free with each purchase of G-Pascal on disk. G-Pascal is available from your local Commodore dealer, Commodore Information Centre Pty. Ltd., or Gambit Games. Recommended retail: \$79.50

\* excludes existing older dealer stocks

If you have already purchased G-Pascal these extra programs may be ordered by sending \$20 direct to Gambit Games.

**Gambit Games** P.O. Box 124, Ivanhoe, Vic. 3079  
Phone: (03) 497 1283.



**PROBLEMS WITH YOUR POWER SUPPLY?**

A Line Tamer ensures constant voltage and interference suppression for your computer gives a nominal 240V from fluctuating supplies as low as 190V. eliminates spike voltages caused by lightning etc



**YOU NEED A LINE TAMER®**

There's a Line Tamer to suit your installation. Send for data  
Ferguson Transformers Pty. Ltd.  
331 High Street, CHATSWOOD 2067 Tel: (02) 407 0261  
Telex: AA25728. Melbourne (03) 328 2843

Registered Trade Mark of Ferguson Transformers Pty Ltd



# SPEEDY SOFTWARE SUPPLIES

Prices Inc. Tax.

APPLE..COM-64..IBM

Flight Simulator

(Sub Logic) .....	46.50	53.95	N.A.
Loderunner .....	42.50	34.50	N.A.
Sargon III .....	62.95	N.A.	N.A.
Deadline .....	62.00	62.00	65.95
Witness .....	N.A.	50.00	61.95
Alpine Encounter .....	45.00		
New Vodac Adventure Series by IBIDING.			

**FREE FREIGHT AND HANDLING**

For Software not listed and FREE CATALOGUE

Write to us, or phone (076) 38 2022

**SPEEDY SOFTWARE SUPPLIES**

177 Campbell St.,  
Toowoomba, 4350

**FREE**

**Club Membership with initial order over \$100.**

Guaranteed — Speedy delivery or Money Back 14 days.

# EASY DESK

## MOBILE COMPUTER DESK



Teak-laminated shelves. Width 900mm. Depth top shelf 300mm, depth bottom shelf 400mm. Height of bottom shelf 670mm.

**\$99**  
**DELIVERED TO YOUR DOOR!**

Name .....

Address .....

State ..... Postcode.....

Cheque enclosed Signature .....

Bankcard 4 9 6 - - - - - HC/YC

**POST TO: HOME COMPUTERS,**  
160 Burwood Hwy, Upper Ferntree Gully. 3156. Tel: (03) 758 2124



## THE BEST QUALITY FLOPPY DISK DRIVE FOR YOUR APPLE®

### FEATURES OF NEW Super-5(T-40e)

- USER SELECTABLE WRITE-PROTECT AND HEAD-SEEK SPEED.
- CUSTOM LSI DESIGNED—MORE RELIABILITY
- ALL C-MOS IC USED—LOW POWER CONSUMPTION
- DRIVES SPIN BRIEFLY WHEN A NEW DISKETTE IS INSERTED FOR PRECISE DISKETTE/ SPINDLE ALIGNMENT

**\$245.00**  
**inc. tax**

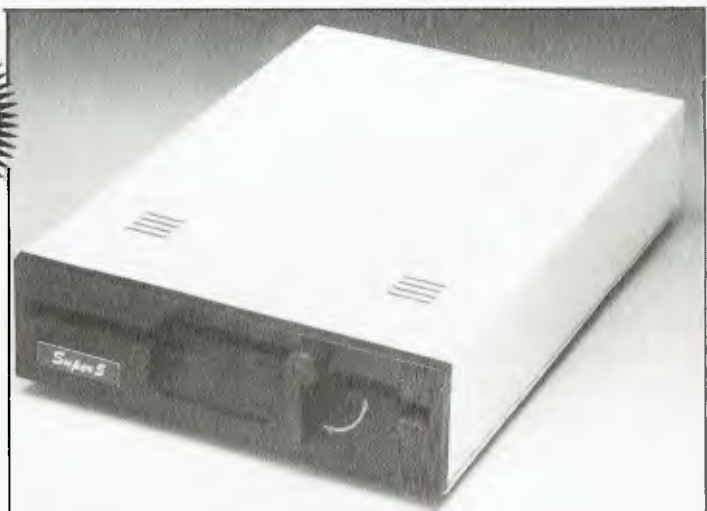

## MULTITECH COMPUTERS

202 High St. Northcote 3070  
Phone (03) 489 0430. Telex AA38581 Polygon

# Starts small, thinks big

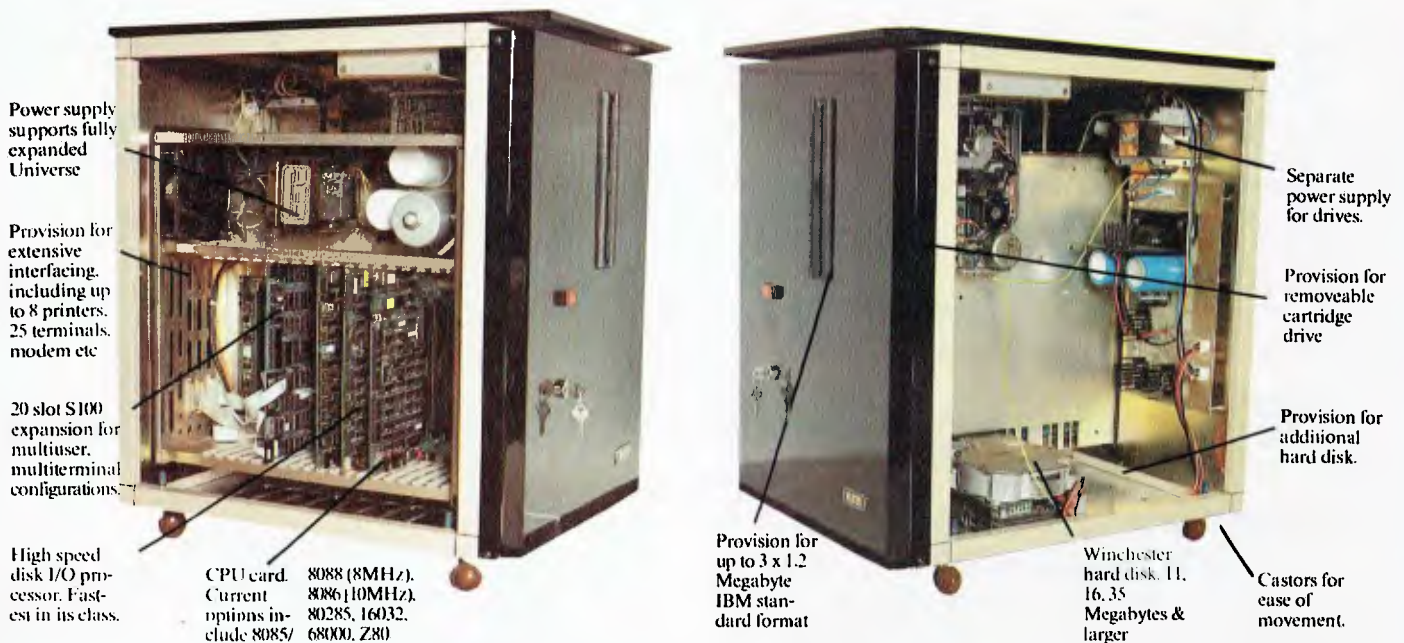

Universe is the right computer for large *and* small businesses. Totally modular design means it's right for your needs *this* year yet able to grow inexpensively *next* year.

Costing no more than some similarly optioned personal computers, Universe provides reliability, expansion potential and speed that these machines cannot offer:

Here are some of the reasons why you should consider Universe over other computers:

## 1. You'll keep it longer!

Universe can be upgraded - no need for expensive replacement of a machine that can't do the job. No need to pay for more machine

than you need right now. As new developments come along they are available *first* on Universe and they plug straight in.

2. If there is a program dead right for your business there is more chance it runs on a Universe. You have access to over 75% of available application software. Most PCs give you access to less than one third of this software.

3. Universe can expand to help your whole business. Adding extra workstations is fast and easy. A few PCs offer 'networking' where several small computers share the data storage. This arrangement is *unworkably slow* in the majority of business

applications. Universe provides the right solution. Our Multiuser system gives everybody fast access to information.

4. Universe lets you do several things at once. Other computers only let you do one thing at a time. Swapping between programs is slow. Using our unique MPS (Multiple program facility), Universe lets you move between any 10 programs almost instantly - an incredible time saver.

5. Universe gets its work done faster. On industry standard sorting tasks (which relate to many tasks you will probably use the computer for) Universe runs 3 times faster than an IBM PC and twice the speed of and NEC APC.

# UNIVERSE SUPERCOMPUTER

# All the software you'll need:

Here's just a sample of the software running now on the Universe Supercomputer.

## LANGUAGES

Aztec-C86  
Aztec-C11  
CIS Cobol Level II  
BDS-C Compiler  
Pascal MT+  
Assembler  
C-Compiler  
C-Basic  
PL/I  
Basic Interpreter  
Cobol Compiler  
Access Manager  
Animator for Cobol  
Fortran 77  
C-Basic 86

## DATA MANAGEMENT

Friday  
Rescue  
FMS-80  
Data Minder  
Datastar  
Dbase II  
Dbase II (report writer)  
Quickcode  
Condor  
Knowledgeman  
Mdb3 III  
Infostar  
Dataflex  
Delta

## COMMUNICATIONS

BSTAM  
BSTMS  
Hite  
Term 2  
YAM  
XMODEM  
XYAM

## WORD PROCESSING

Wordstar  
Spellstar  
Mailmerge  
Star Index  
Spellguard  
Postmaster  
Typequick

## DEVELOPMENT

Wordmaster  
Macro-80  
Sid & Zsid  
Mac  
Aztec-C  
Distell & Disilog  
Rasm-86

## ACCOUNTING

Davidson  
I.A.L.  
Padmede  
I.M.S.  
A.M.S.

## INDUSTRY SPECIFIC

Manufacturing  
Medical  
Restaurant Accounting  
Video Library  
Sales Organisations  
Dental  
Pharmacy  
Dietician  
Legal Retrieval  
Management  
Real Estate

## FINANCIAL MODELLING & STATISTICAL ANALYSIS

SuperCalc-86  
Micromodeller  
Masterplanner  
T/Maker III  
CalcStar  
Abstat Statistics  
Scratchpad 2.0  
Statpak  
Milestone  
Planfin  
Profin  
Miconet  
Multiplan

## OPERATING SYSTEMS

CP/M-80  
CP/M-86  
Concurrent CP/M-8/16  
Concurrent MP/M-8/16  
Concurrent MP/M-86

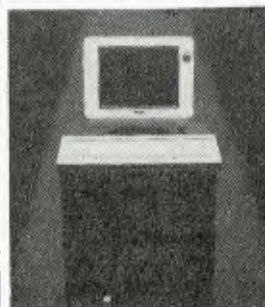

Please send me further information on the Universe Supercomputer.

**Note:** We have special arrangements for consultants and dealers. Please contact Wayne Wilson on (02) 636 7677.

Name \_\_\_\_\_

Address: \_\_\_\_\_

Phone: \_\_\_\_\_



**Sydney:** Unit 3, Prospect Industrial Centre, 2 Stoddart Road, Prospect (02) 636 7677

**Melbourne:** 53 Waverley Rd., East Malvern Vic (03) 211 5542

**Canberra:** 217 Northbourne Ave., Canberra ACT (062) 47 3403

**W.A.:** AED WA, Computer Services of WA (09) 450 5888

WE OFTEN think about the future, don't we? Computer users perhaps more so than most. As the Professor so often asks in his now famous television commercials for a well-known chocolate manufacturer – "Why is this so?" Is it because we are very concerned about our children's futures, or because we fear that the world of high technology, 'bits and bytes', will overwhelm us and maybe make us all obsolete as workers?

It was with this future in mind that I read, with much interest, the January '84 issue of *Softalk* magazine from the United States. In it was an article by staff writer Tommy McGear, in which computer industry heavies such as Bob Clardy, Bill Budge (Pinball Construction Set), Dan Gorlin (creator of Choplifter), Scott Adams, John Sculley (President of Apple Computers), and Steve Wozniak (Apple founder) let the rest of the world in on what they foresee will happen in the realm of computers.

Each saw a new breed of computer – one which is more user-friendly, which we could 'relate' to and which would offer much more (in terms of memory, processing speed, artificial intelligence and so on) for little or no extra than what we pay for the machines of today. A most interesting question was "Who would make this wondrous machine?" The interviewees saw stiffer and fiercer competition among the world's manufacturers, leading to what many computer industry observers refer to as 'the hardware/software shakeout'. It was expected last year and, indeed, part of it did take place, with Texas Instruments, Mattel, Timex-Sinclair (in the US) and Atari all either going down altogether, or at least losing many millions of dollars in the home computer marketplace. The introduction of new machines from Apple (IIC, Macintosh and Lisa versions) and IBM (PCjr) this year will make things very interesting for other manufacturers.

That appears to be one side of the coin. It is the fear of a computer manufacturer going 'bust' (which we Ninety-Niners know only too well, but have come to live with) that is in the back of every prospective computer buyer's mind. Most salespeople agree a computer is virtually outdated from the time you carry it out of the shop. Some buyers hold their breath, waiting for the next 'big thing' to arrive, only to find that it too will be superseded in the not-to-distant future. So what do you do?

A recent survey in the United States

found only nine per cent of households interviewed in a nation-wide survey had any interest in buying a personal computer in the near future. Can this be the same country in which forecasters expect to see the majority of homes to have a personal computer by the turn of the century?

Texas Instruments, although the largest supplier of semiconductor components in the world, seems to have suffered badly in the personal computer marketplace. Not without fault, some might add. According to a recent news item in *Pacific Computer Weekly*, Texas Instruments did \$US1.34 billion worth of business in the first quarter of 1984. Now you might understand why the 99/4A may have been treated as nothing but a minor 'hiccup' in the boardrooms in Lubbock, Texas.

TI now plans to manufacture the National Semiconductor 32-bit microprocessor (Series 32000) in partnership with Nat-Semi. Mr Fred Bucy, TI's president, was quoted as saying that TI wants to get into the 32-bit market where multi-tasking is all the rage. He gave Apple's Macintosh and Sinclair's QL as examples of this market.

Now, back to the original question: what does the future hold? Will the TI-NatSemi partnership be the one to produce this new machine? Well, TI has already earned glowing praise for the voice synthesis unit on its Professional Computer in the pages of *Your Computer* (see Evan McHugh's report on the PC84 exhibition in the May issue). But it appears TI's problems won't go away. Spanners are continually being thrown into the works. Apparently TI has been caught with an estimated \$US30 million worth of inventory in its US warehouses which it cannot rid itself of. Many of the company's previous customers are refusing to re-order Home Computer software because they fear as soon as they do TI will reduce its prices further, leaving the retailers thousands of dollars in the red. A TI employee was quoted as saying in an *Enthusiast* '99 news item, "It looks as if we have only two options at this time. We can drastically reduce the prices on our remaining inventory or dig a big hole (Atari-style) in the west of Texas and bury it." TI is therefore in a Catch-22 situation. If it reduces its prices, retailers will be further alienated; if it holds on to stock, it loses more money as valuable warehouse space remains occupied.

One observer noted that TI modules could be selling for as low as \$US4.95

in many major chain stores by the US summer!

### Software Review

I have seen some truly excellent software recently. One game in particular impressed me with its use of colour, graphics and sound effects. So often you find music and sound effects which appear to be afterthoughts, but 'Space Aggressor' by Brian Lemoff looks like being a winner – not only for its exciting game play action, but also for its realistic music and sound effects.

I will give you a brief description of the game. First, it is written in TMS9900 Assembly language and is therefore very fast (but not so fast that you can't enjoy beating it with a bit of practice). It comes on diskette and loads through Extended BASIC. To run it you will need 32K extra memory.

You are the captain of a spacecraft moving to and fro across the sky. (You have to see this spacecraft to believe it – it is a real beauty!) Your joystick controls movement, and the fire button releases laser bolts at various alien species that pass beneath you. Some aliens move quickly and are worth more points, while others move more slowly. All the aliens launch deadly missiles at you, which you must avoid in order to stay alive – you have three chances.

Sounds hard? Not once you get the hang of it. But that's not all. You must also avoid hitting the floating blue space mines; if you don't, they rebound your fire and blow you into pieces of space debris. My only quibble about this game is the explosion at this point could have been more realistic, along the lines of the explosions in 'Parsec'. On each side of the screen are small yellow patches that emit rockets, and if you hover over either of these areas for too long you are definitely in danger.

As I said before, this game is joystick controlled and the control is exceptionally smooth. I found that even with the unpredictable TI joysticks, Space Aggressor was a lot of fun and highly addictive.

### Book Reviews

As I mentioned in my previous column, I have received a number of books on various aspects of home computing. All those reviewed below have been kindly supplied by William Collins. If you would like more information, contact the Special Projects manager, Sandra Gorman, at Collins on (02) 290-2066.

The first book *Learning To Use The* ►

# SANYO OWNERS!

## MBC 555 PROFESSIONAL UPGRADE From Floppy Disk to 5 1/4" Hard Disk for only \$2995\*

Bring in your Sanyo with its inadequate Floppy drive to convert to a truly professional system. Turn 360K capacity into an incredible 11250K's capacity. That's over 30 times the storage — 30 times the user capability. Mr. Hard can build-in the new 5 1/4" Microscience Hard Disk Drive into your existing Sanyo for only \$2995\*

## NEW SANYO BUYERS!!

When you purchase the MBC 550 you can have Hard Disk fitted giving you a complete professional system for only \$3990\*

### MBC 550 + Hard Disk features:

- 1250K storage memory • IBM disk compatible
- Centronics port standard • MSDOS
- 256K memory upgrades • 8088 Processor: 16 bit
- Optional serial single or double ports

### Factory Options:

720K Drive Upgrades — Call Now  
128K to 256K upgrade — \$200\*

Hard disk drive service and repair in Australia's only HDA "Clean room" facility.

\*All prices Rec. Retail incl. Sales Tax.



## Mr. Hard

HARD DISK DRIVE division of Mr Floppy

9 ADA AVENUE, BROOKVALE, 2100

(02) 939-1800

★ INTERNAL IBM HARD DISK UPGRADES AVAILABLE — CALL NOW FOR DETAILS.

Is 1984  
the  
year...

you are going to deliver  
the benefits of IBM or ICL  
Personal computers to your  
organisation ...

If it is ... whether you want a  
small business system or a  
large corporate network  
you should be talking to us.

**THINK  
COMPUTERS**

602 Maroondah Hwy., Mitcham Vic. 3132  
Telephone: (03) 873 1122

IBM

ICL

PLEASE SEND FURTHER INFORMATION

NAME

COMPANY NAME

ADDRESS

PHONE

## new compal multi-mode COMPUTER DESKS

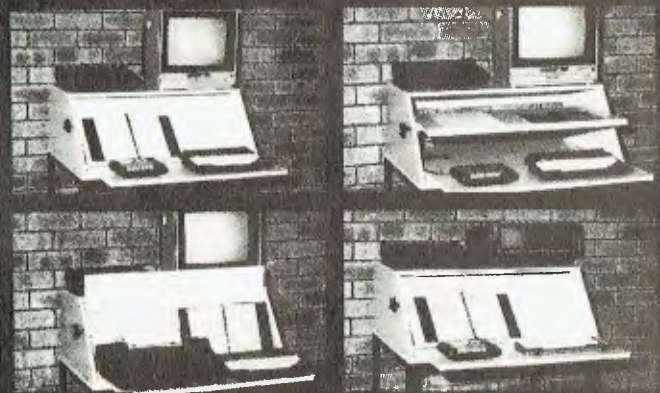

PROFESSIONALLY DESIGNED WORKSTATIONS WITH ALL THE FEATURES REQUIRED FOR PERSONAL COMPUTERS.

Unique slide away desk and ingenious multi-position notes rest stand and dust cover.

AVAILABLE IN TEAK, BEIGE, OR PINE MELAMINE.

\$235 delivered FREE 800mm wide model shown, legs incl.

To order: send name, address, finish with cheque, Bankcard, Mastercard, or Visa.

**spacestation** computer  
furniture

414 STIRLING HWY., COTTESLOE, 6011. (09) 384.8499

T199/4A, by Kevin Townsend (Gower, paperback, 198 pp, illustrated with glossary, rrp \$9.95) is very useful for students new to BASIC, especially TI BASIC, as the foreword points out. Already much has happened since this book was published in 1983 – the list of further reading includes magazines which gave up publishing 99/4A material many months ago, or which have disappeared. There is also a short annotated bibliography, but I haven't seen many of the books listed available locally. As for the content and layout: I found it entertaining and enlightening. The book's five chapters are clearly written and cover all aspects of TI computing. The last chapter looks at the special features of the 99/4A, including music and speech. There is also a glossary of computer terminology. Well worth your inspection.

Another book, for younger readers, is the *Granada Guide To Computers* by Tom Fry (Granada, paperback, 64 pp, colour illustrations with glossary, rrp \$3.95). This is excellent value for a general introduction to the world of high technology. The author traces the history of computers from the abacus to the

silicon chip. Junior High School students studying computers and their impact on society would find useful material here for assignments.

*Computing For The Hobbyist And Small Business* by AP Stephenson (Granada, paperback, 200 pp, rrp \$12.95) looks with some depth into the use of computers for essential business tasks, such as stock control, word processing and the use of CP/M. It doesn't attempt to teach BASIC, and its only program, listed in full, is for the BBC Microcomputer (did you see the series on the ABC recently?). However, a lot can be learnt from its pages. From its first chapter on how hobby computing began (PET 2001, ZX80, VIC-20 and so on), to the last chapter on storage devices and networking, the book is concisely written with helpful summaries at the end of each chapter for review purposes. The author doesn't use a lot of jargon when he knows a simple diagram or illustration best explains what he wants to say. The hobbyist is catered for with chapters on ROMs, EPROMs, PCBs, microprocessors (for example, Z80 and 6502) and even DIY computer

furniture.

I particularly enjoyed the chapter on program writing and development. It is reasonably up-to-date, dealing with program generators (The Last One, for example), flowcharting and debugging. The author has a sense of humour, too: under the heading of phases in program development he lists Step 12 (after making back-ups and writing documentation) as "Go to the pub and relax!" Anyone who has ever written a program knows just what the author means!

Two very useful books which any serious 'Ninety-Niner' should consider are *Introducing Logo* by Boris Allan (Granada, paperback, 112 pp, illustrated, rrp \$12.95) and *Exploring Forth* by Owen Bishop (Granada, paperback, 176 pp, illustrated, rrp \$12.95). These are newly published books, but both should be available by the time you read this. Logo II has been available for the 99/4A for some time now, and Forth (from the Forth Interest Group, or FIG) has just been made available on diskette for those with the Editor/Assembler Package and a fully expanded TI system. Both languages, while worlds apart

# SIMPLY BEAUTIFUL



## THE CONCEPT, THE SYSTEM, THE FLEXIBILITY

### The Concept

The Sierra Multi-Processor computer systems by Microtrix were designed to provide users with the fastest, most flexible multi-user systems available. Up to 16 users can be attached to the system, each user having his own processor card, memory, and input/output ports. To obtain the maximum performance from our hardware, we chose the advanced TurboDOS operating system. Networking TurboDOS provides more powerful and expanded features than either CP/M or MP/M while still remaining file compatible. Performance rivals minicomputers.

### The System

The Sierra multi-user system is available in several forms. The desk top version shown can be configured with either two 8" floppy drives or one 8" floppy drive and a hard disk. Up to five users can be supported. Other versions can maintain up to 16 users. Hard disks are available in various sizes.

### The Flexibility

The built-in flexibility means a user can buy a system tailored to his requirements now, and then upgrade as circumstances require. Contact us now for further information on a configuration to suit your requirements. You'll be pleasantly surprised at how much computing power your money can buy.

## The Sierra Multi-Processor: Simply Beautiful



MICROTRIX PTY. LTD.  
24 Bridge St.  
ELTHAM, VIC. 3095  
Phone: (03) 439 5155  
Postal: PO Box 158  
HURSTBRIDGE VIC., 3099.

Dealer Enquiries Welcome

# RIGHT PRICE. RIGHT SIZE. RIGHT SPEED. That's Riteman!



RITEMAN 15



RITEMAN PLUS  
(Tractor feed and cover optional)



RITEMAN II

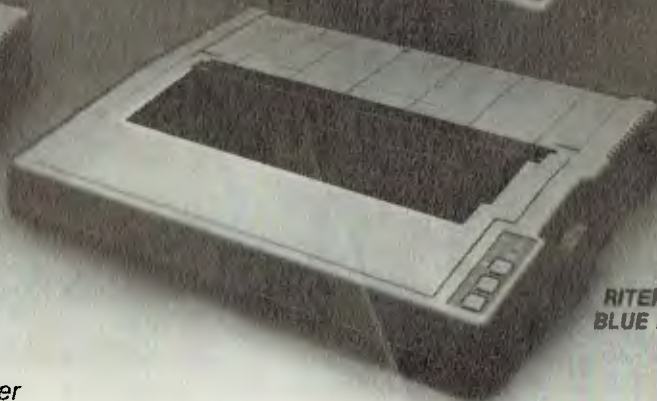

RITEMAN BLUE PLUS

If you're looking for an Epson\* or IBM\*\* compatible dot matrix impact printer that's lower in price, smaller, durable, and fast enough to keep pace with your work flow . . . we'd like to show you a Riteman!

Four great new printers. All priced well against comparable Epson models. All substantially smaller. Yet solid as a rock. With print speeds up to 50% faster than the competitors.

The Riteman Plus, Riteman II, Riteman 15, and Riteman Blue Plus with IBM

graphics. All are backed by a full one-year warranty. And, as you can see, they're great-looking, too!

So see your dealer today . . . and get the Riteman for your printing job!

\* Epson is a registered trademark of Epson America, Inc.

\*\* IBM is a registered trademark of International Business Machines Corp.

## RITEMAN:

For further information contact your local Warburton Franki office.



# Warburton Franki

A DIVISION OF THE ANI CORPORATION LTD (INCORPORATED IN N.S.W.)

- ADELAIDE (08) 356-7333
- BRISBANE (07) 277-0222
- HOBART (002) 28-0321
- MELBOURNE (03) 795-9011
- PERTH (09) 277-7000
- SYDNEY (02) 648-1711
- AUCKLAND N.Z. (09) 50-4458
- WELLINGTON N.Z. (04) 69-3016

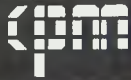

# C.P.M. MINI CONQUEROR

## THE COMPLETE DESKTOP SOLUTION — POWERFUL, EASY-TO-USE, FRIENDLY, RELIABLE

**COMPRISING:**

- 12in green screen terminal, on swivel base with detachable keyboard 95 keys, separate numeric key pad, 10 function keys, built-in graphics capability
- Z80A running at 4MHz
- 64K bytes of RAM, 4K bytes of ROM
- 1—Centronics port.
- 2 RS232 serial ports Software selectable baud

rates to 38.4K baud

- Mass storage two double sided, 80 track disk drives, 800K bytes (formatted) per diskette 1.6M-bytes total internal storage
- CP/M 2.2 with enhanced BIOS & CCP
- Integrated accounting software General Ledger, Accounts Receivable, Accounts Payable, Stock Control & Invoicing.
- Reads/writes other popular computer formats

**OPTIONAL:** (1) T Maker III software \$365.00\*\*, wordprocessor/spreadsheet/database management/ bar charting (2) Friendly — operating system overlay — \$79.00\*\*. (You won't have to learn how to use CP/M

**SPECIALISED BUSINESS SOFTWARE:** For nearly all fields, e.g. motel, insurance, real estate, medical/dental, farming, video shops, etc etc, also available.



**STOP PRESS**

**WE NOW INCLUDE THE FOLLOWING SOFTWARE**  
★ WORDSTAR ★ MAILMERGE ★  
★ CALCSTAR ★  
★ DATASTAR ★ REPORTSTAR ★

**CALL US FOR SPECIAL INTRODUCTORY PRICE**

### SOFTWARE AUTHORS/DEVELOPERS & DEALERS

At last a computer that lets you read/write/format virtually all soft-sectored CP/M formats, whether single or double density, single or double sided, 5" or 8", 48 TPI or 96 TPI.

**INCLUDES:** • Z80A at 4MHz.

- 2 serial ports for printer/modem/ & terminal
- 1 5 1/4" DSDD 40 track 48 TPI drive
- 2 5 1/4" DSDD 80 track 96 TPI drive
- 1 8" DSDD 77 track drive
- CP/M 2.2 & all disk format conversion software and utilities

**ALSO AVAILABLE:** 16-bit computer (IBM PC compatible) for format conversion, or buy software separately, see details in this ad.

### COMPUTER MEDIA TRANSCRIPTION/COPYING

- Software duplication, copying and formatting for virtually all popular computers
- Downloading 8" CP/M formats to over 60 5 1/4" CP/M formats.
- Conversion and downloading from CP/M to MS-DOS/PC-DOS.
- Copy protection for most popular formats.
- Rapid turn around.
- Reasonable charges

### SPECIAL IBM PC (AND COMPATIBLES) UTILITIES

- OPERATING SYSTEM CONVERTERS: • DATA/TEXT FILE CONVERSION:



## CP80 Printer

Incredible new low price at

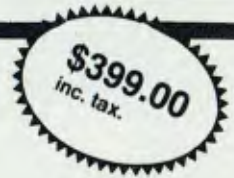

**CP80 Ribbons \$12.00 inc. tax. (while stocks last)**

• **Atari Printer Interface (ATP/1)**

This new low cost Interface plugs into joystick Port 3 and allows you to use any printer with a standard centronics interface.

**\$95.00 inc. tax.**

• **Atari Modem Interface (ATM/1)**

This new Interface plugs directly into joystick Port 4 and provides you with standard RS232 output. You can then use any off the shelf Modem also Printers that require RS232 Input.

**\$75.00 inc. tax.**

• **Atari Eprom Burner (ATE/1)**

This new unit allows you to burn 2K, 4K, 8K, Eprom's. Now you can burn all your favourite Programs into Eprom's.

**\$165.00 inc. tax.**

\***Eprom Cartridge Boards (4K, 8K, 16K)**

**\$15.00 inc. tax.**

**All of the products above are Australian designed and Produced, and come with a 12 month Warranty.**

- Apple Centronics Printer Interface **\$95.00 inc. tax.**
- Microbee Printer Interface **\$45.00 inc. tax.**
- Spectravideo Printer Cable **\$35.00 inc. tax.**
- BBC Micro Printer Cable **\$40.00 inc. tax.**
- Box of 9 1/4" x 11" Paper (2000 sheets) **\$29.00 inc. tax.**

(All Products Available while stocks last)

Dealer Enquiries For The Above Atari Products Are Welcomed.

**Compsoft Manufacturing Pty. Ltd.**  
2 Wiltshire St. Richmond, Victoria, 3121  
Phone: 429 9779, 429 4952

**Compsoft Microcomputer Services Pty. Ltd.**  
233-235 Swan St. Richmond 3121.  
Victoria. Phone: 429 9686, 428 5269

in both operation and philosophy, are powerful learning tools.

*Introducing Logo* is an excellent introduction to this children's computer language, and it would certainly complement the documentation supplied by Texas Instruments. The author enthusiastically believes Logo to be "an egalitarian language", with applications in artificial intelligence, graphics (Turtle), and teaching pre-schoolers and handicapped children. This enthusiasm is infectious and it becomes hard to resist the lure of such a relatively easy programming tool (when compared to BASIC). There is even a version of the well-known Eliza. The best thing about this book, for us, is that the examples given can be directly applied on the 99/4A. Teachers would find this book useful, too, especially the last chapter on learning to use Logo.

*Exploring Forth* (great title) is a beginner's guide, and assumes no previous knowledge of this computer language. In fact, the author encourages experimentation when using the examples in the book. Like Logo, Forth is a relatively easy language to transport. It is also

very fast and flexible. For example, you can define a procedure like 'duplicate' (which might be difficult for a young computer user to understand) as 'make-two', as in

```
: MAKE-TWO DUP ;
```

The author shows Forth to be an excellent language for both advanced users and beginners. I used quite a few of the examples with my FIG-Forth disk, and except for some procedures like 'dot-S', all worked perfectly. An appendix at the back of the book sorts out these problems with alternative procedures. I would, therefore, recommend this book to anyone interested in learning more about Forth — a viable alternative to Assembly Language.

The last book for this month is *The Complete Programmer* by Mike James (Granada, paperback, 149 pp, rrp \$12.95). The author claims his "is one of the few books which teach methods and methodology in BASIC (and) is not tied to any variant of the language, nor to any particular model of microcomputer." That claim has been made many

times before, so how does it shape up? Twelve chapters cover methods of programming, defining and organising data, random number generation, graphics, sorting, searching, testing and debugging. Generally, with the exception of a few PEEK, POKE and PLOT commands and some LEFT and RIGHT string segmenting, the author is true to his word. This book is not for the BASIC beginner, since it assumes prior knowledge.

### Short Sprite Demo

Here is a short program, in Extended BASIC, for creating 3-D sprites:

```
100 REM 3D SPRITES
110 REM IN EXTENDED BASIC
120 CALL CLEAR
130 CALL SCREEN(2)
140 CALL MAGNIFY(2)
150 FOR SPRIT=1 TO 26
160 CALL SPRITE(#SPRIT,64*SPRIT,
    INT(SPRT/2)+3,10,10,20,104-
    SPRIT*8)
170 NEXT SPRIT
180 GOTO 180
```



# Output Media

CUSTOM PRINTED FORMS MANUFACTURER

**wabash** 6 YEAR WARRANTY DISKETTES

**SPECIAL**  
**\$25**

PER BOX  
OF TEN  
DISKETTES  
for 5 1/4" SS/SD. (Inc. tax).

FULL RANGE DISKETTES AND TAPE  
**PHONE NOW 544 4400**

OR CALL  
IN AT:

Unit 19/170 Forster Rd., Mt. Waverley, Vic. 3149  
TELEX: AA134947

Fill in this coupon and return with  Cheque or  Bankcard Authorisation for POST FREE delivery by return mail.

Please Mail.  Boxes of 10 Diskettes at \$ \_\_\_\_\_ per box.

To Mr \_\_\_\_\_  
Ms \_\_\_\_\_

Company \_\_\_\_\_

Address \_\_\_\_\_ P/Code \_\_\_\_\_

Telephone ( \_\_\_\_\_ ) Value of order \$ \_\_\_\_\_

Charge my Bankcard account

Signature \_\_\_\_\_

Expiry Date \_\_\_\_\_

Name \_\_\_\_\_

Address \_\_\_\_\_

Postcode \_\_\_\_\_



**Speedway Blast**

This program is manufactured by IDSI, the same people who created Pool 1.5. Written in machine language, it requires 16K and slightly resembles the arcade game 'Rally X'.

You begin with three cars and must navigate through streets and neighbourhoods, avoiding inanimate objects such as houses, bridges and trees. At most intersections there is a monster egg, about to hatch. If you run over the egg before hatching you get 100 points, as well as 100 units of fuel. However, if you fail to reach it the egg hatches into a monster which will destroy your car on contact. The monster moves fairly slowly, and only in the general area of its egg. It doesn't travel around the whole neighbourhood.

The monsters don't shoot back and this, to some extent, detracts from the potential of the game. You may shoot the monsters to obtain more points and continue your mad drive. After clearing the streets of eggs and monsters, you are given another board to attack; this time the car moves faster and the eggs hatch more quickly. On level four, for instance, you have to be very quick to obtain enough fuel from the eggs before the monsters hatch.

The car is controlled by a joystick and is fairly easy to manoeuvre; pushing the joystick forward makes the car accelerate, and pulling backwards slows the car and eventually stops it. You can quite often crash into a monster or wall simply because the car does not brake in time.

To help you with the mapping of the streets, a radar map, as in Rally X, is provided at the bottom of the screen. You are represented as a cross, the eggs as dots, and the monsters as blobs.

The only real complaint I had, other than the controllability of the car, is that the eggs can change to monsters just as you pass over them - causing you to crash.

Each car starts with 999 fuel units, and explodes when the tank is empty. You earn an extra car at 10,000 points.

Although this game tends to get repetitive I found it quite enjoyable, and even addictive.

**Lotto Checker**

The program in Listing 1 will check your Lotto coupons for you, though it can't increase your chances of winning (sorry!).

If you use the same Lotto number

each week, change the DATA statements to your choices in each of the games. If, however, you change your numbers each week, just leave that part of the program free of statements and add those lines each week when you choose the numbers.

Now, change the variable 'C' to the number of games you play each week - it is set to twenty.

After the draw on Saturday night (or whenever), run the program, and enter the six numbers and supplementary that were drawn. The program checks each game with these seven numbers, and lists a result in the form of N6, S0, R1 (six numbers, no supplementary, result - div1).

If you have more than twenty games and the program scrolls too fast for you, press CTRL and 1 simultaneously to pause output. Press them again to continue.

**Listing 1. Lotto Checker program.**

```

1 GRAPHICS 0
5 REM - gold lotto checker
6 REM - BY ERNIE SUGRUE
7 REM - FOR 'YOUR COMPUTER'
8 REM - (C) 1984 - 6JUL84.
10 GRAPHICS 0: DIM A(120),N(7),M(7),B(6): D=20
20 FOR I=1 TO 120: READ B:A(I)=B:NEXT I
30 FOR I=1 TO 6: ? "Input draw number "I:
INPUT N:M(I)=N:NEXT I: ? "Supplementary
: "I: INPUT N:M(7)=N
40 FOR I=0 TO C-1: FOR K=1 TO 6: FOR F=1 TO 6:
IF A(I*6+K)=M(F) THEN Z=Z+1
45 NEXT F: IF A(I*6+K)=M(7) THEN V=1
50 NEXT K
60 ? "Game number "I+1: " results: "Z: "N,
: "V: "S. "
65 IF V=1 THEN Z=Z+0.5
70 IF Z=6 THEN ? "R1": GOTO 80
71 IF Z=5.5 THEN ? "R2": GOTO 80
72 IF Z=5 THEN ? "R3"
73 IF Z=4 OR Z=4.5 THEN ? "R4"
74 IF Z=3.5 THEN ? "R5"
75 IF Z<3.5 THEN ? "R0"
80 IF Z>3 THEN ? " "
85 Z=0: V=0: NEXT I
100 DATA 7, 17, 20, 24, 34, 40
101 DATA 6, 9, 14, 21, 26, 28
102 DATA 2, 10, 16, 25, 27, 40
103 DATA 4, 9, 17, 22, 28, 35
104 DATA 1, 11, 13, 21, 28, 36
105 DATA 4, 11, 16, 21, 24, 31
106 DATA 4, 11, 18, 17, 34, 38
107 DATA 1, 5, 7, 15, 21, 30
108 DATA 7, 12, 16, 29, 34, 37
109 DATA 7, 9, 18, 24, 34, 37
110 DATA 3, 12, 20, 24, 34, 38
111 DATA 1, 11, 13, 17, 32, 40
112 DATA 2, 7, 10, 19, 22, 26
113 DATA 4, 9, 14, 19, 24, 40
114 DATA 7, 6, 11, 35, 39, 40
115 DATA 4, 7, 16, 20, 25, 38
116 DATA 2, 7, 20, 27, 34, 38
117 DATA 2, 7, 10, 20, 23, 34
118 DATA 7, 9, 20, 24, 34, 36
119 DATA 2, 7, 17, 20, 30, 34

```



**Double your Disk Space**

If, like most of us, you use single-sided, single-density disks, you can double the available storage space by cutting another 'Write Protect' notch into the disk.

To do this, simply use a hole-punch to cut half to three-quarters of the original hole's size exactly opposite the notch which is already there. If, when you try to format the disk, your disk drive appears to be having a coronary, remove the disk, enlarge the hole, and try again.

If you back up all your disks (as you should, for your own protection) don't back up a disk onto the other side; because if the fault wipes one side, chances are it'll wipe the other side, too.

**Information on Demand**

**- Update**

As you may remember I wrote a review of the Source a few months back, and in it I made a reference to Information on Demand. IOD is an American company which will obtain documents, reprints, journals, annual reports and a variety of other publicly available information on almost any subject.

I decided to try IOD out, and ordered the annual reports of two large American companies. Acknowledgement of my request took three days to arrive in my Source mailbox, instead of the 24 hours advertised - but it was a major holiday weekend. I heard no more from IOD until the reports arrived about five weeks later by airmail from California. They were in good condition and were very up-to-date (March 1 1984). Two weeks later, I received general information on IOD, explaining its services and charges. I also received a note saying the documents I had requested were not available, but were being ordered and would take two to three weeks to arrive - even though I had received them three weeks before this.

Apart from that little hitch, nothing went wrong.

The bill for the two reports came to \$47.

If anyone wants a copy of the information I received on IOD, send me \$2 and I'll post it to you. My address is PO Box 594, Maryborough 4650.

Hope you have enjoyed this month's column.





# PORTA PAK COMPUTER

## ...other computers cringe

PortaPak comes with its sleeves rolled up. It was designed in Australia to get the most work done in the least time and at the lowest price.

If you want results, sheer computing power, trouble free performance, then PortaPak is the only choice. If you want prestige, if you need to stroke your corporate ego, we suggest you buy something else. Something that costs more, isn't as powerful but has a lot of "image."

Put PortaPak up against imported machines costing \$5000, \$6000 even \$7000. The other machines cringe with embarrassment.

PortaPak has 800K of formatted space on each disk drive. The expensive machines which boast about having 360K suddenly look rather silly. With PortaPak you'll be able to handle much bigger data files and have far more programs on hand without having to fiddle around changing disks.

Reliability is often thought of in terms of machine breakdowns. Nowadays, the big problem isn't with breakdowns it's with hangups - when your machine turns out to be incompatible with your software. This is an enormous, widespread problem.

It's why we teamed up with Australia's software geniuses - Software Source Pty Ltd, the top suppliers of business and professional programs in the country. First, they specially customized PortaPak's operating system so it works with exceptional speed and simplicity.

Then they customized all their CP/M products to run perfectly on the PortaPak - products like dBASE II, SuperCalc, all the major languages, accounting

systems, etc. Most importantly, they stake their reputation that all these products will work without hitches. No other computer in Australia can offer this total software support.

As for electrical and mechanical reliability, look inside a PortaPak. There's a striking difference. The PortaPak is completely modular. We didn't scrimp by putting all the circuits on one board. We use *ibree*. Servicing is simpler, quicker and cheaper. It's why the leading national computer service company, TCG Pty Ltd, is pleased to offer a 12 month service contract on PortaPak in all capital cities.

Take an extra close look at the Canon disk drives. If Rolls-Royce built computers, they'd use Canon drives. See the massive head protection shield? Hear the way the heads lock away every time they deselect? The designers had an unusual attitude to reliability - fanatical.

Now carry out some speed tests. On a standard benchmark test using BASIC routines\*, the timings are: PortaPak 12.9 seconds, IBM PC 16.4 seconds, NEC APC 19.7 seconds and Sirius 16.4 seconds. Using a standard dBASE II routine\*\*, the timings are: PortaPak 8 minutes 11 seconds, IBM PC 11m 52s, Sirius 17m 9s and NEC APC 19m 16s.

The expensive imports really cringe at this because they make so much of being "16-bit" machines. PortaPak is an 8-bit machine and proud of it. Not only is an 8-bit machine inherently better suited to jobs like word processing, accounting, spreadsheets, etc, but the 6MHz clock rate ensures it can run rings around the others even in complicated mathematical tasks.

Now to really rub it in, look at PortaPak's stunning additional features:

- Compact portability. It needs only half the desk space of its nearest rival. It goes with you on business trips, at night, on the weekend. *In one hand, you hold the concentrated working power of an entire office.*
- 9-inch screen, 80-characters wide but with 35 lines instead of 24. You see more of your work and the characters are the normal shape - not elongated. Much more readable.
- 640 x 304 high resolution, dot addressable graphics.
- Free software including Spellbinder word processing and office management system (the most powerful available), EBASIC compiler, MENU to make life easy for new users, MODEM for telephone communications, and Speed Print which lets you continue working while you're printing.
- Universal terminal emulation lets your PortaPak mimic the screen handling of other computers and run the programs installed for them. Your PortaPak can act as a terminal for any computer you care to name.
- Ability to read and write to other 5.25-inch disk formats - e.g. Kaypro and Osborne. Lets you exchange software directly with owners of different computers.
- User definable character set lets you work with foreign alphabets, scientific symbols, etc.
- Five input/output ports for connecting to printers, modems, etc.
- Wide range of peripherals including 5 and 10 Mbyte hard disks, built-in world modem, RAM drive, EPROM programmer, A/D converter, etc.

---

*Radically different, distinctly Australian design using industry standard software.*

---

*Two one-megabyte disk drives - total formatted capacity = 1.6Mb.*

---

*Z80B processor running at six megabertz.*

---

*9-inch screen, 80 characters by 35 lines 640 x 304 graphics.*

---

*Intelligent, capacitive, spill-proof keyboard.*

---

*Entire system including software and sales tax - only \$3,555!*



**THE  
PORTABLE  
COMPUTER  
CO.**

For the name of your nearest PortaPak dealer contact:  
The Portable Computer Co.  
80 Beauchamp Rd, Matraville, 2036.  
Phone (02) 661 4877. Telex AA71063

\*See Australian Personal Computer, Feb., 1984.  
\*\*See Australian Micro Computerworld, Nov., 1983.

# market directory

DEALERS, distributors, mail-order houses and other commercial organisations or individuals who have a message to spread but don't want to outlay the sums required for full-scale advertising can take advantage of our Market Directory — small ads to help those searching for outlets, services and equipment. For details contact *Your Computer* on (02) 662-8888 or write to PO Box 21, Waterloo 2017.

## RS232 — ALL PROBLEMS SOLVED!

**The RS232 Tester** — helps with computer interface problems: Simple to connect; No power needed; displays transmit data.

**\$38 + Tax** Call for details.

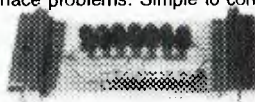

**The RS232 Bit Switch** — designed for versatile interconnection of RS232 devices — "One in", "Three out" change-over switch (bi-directional).

Call for details. From **\$108**  
+ Tax if applic.



**M.F. Computers 9 Ada Ave, Brookvale, 2100**

Ph: (02) 939-1800

Telex: AA 73775

## THE FORTH SOURCE

All Fig publications and listings  
MVP Forth books and software

Forth Encyclopedia \$35  
Starting Forth \$28  
Fig subscriptions \$US27 + \$2 handling charge

### Laboratory Microsystems Inc

FORTH-83 for CP/M, CP/M-86, MSDOS, PC DOS \$120  
CP/M-88k \$300  
Includes screen editor, assembler, decompiler, demonstration programs and utilities, 170 page manual.  
Nautilus cross-compiler to modify nucleus and/or produce headerless ROMable code \$350

(Requires LMI Forth as above)

Hosts Z80, 8080, 8086, IBM/PC, 68000  
Targets Z80, 8080, 8086, IBM/PC, LSI-11, 6502, 68000  
Send 4 x 9 SAE for full listing

## COMPUTER REALM PTY. LTD.

1/100a Young Street, Frankston 3199.  
(03) 29 2600 or (03) 781 4661

## HIGH RESOLUTION/HIGH QUALITY MONITORS

for any computer complete with tilt/rotate stand.  
**AUSTRALIA'S LARGEST MAIL ORDER MONITOR SUPPLIER.**

GREEN from \$170-\$185. AMBER from \$175-199.  
NTSC (colour) from \$290.

All on 14-day Money Back Guarantee and full 6 months arts/Performance Guarantee.

For next day delivery contact us 6 days weekly:

## VIDEO TECHNOLOGY (MONITORS)

17-19 Herbert St., Dulwich Hill,  
or call (02) 569-3015

## COBOL FOR M6809 FLEX (TM)

At last an (affordable) COBOL compiler for the FLEX9 (TM) Operating System!

- most level 1 & some level 2 features.
- full 10 digit BCD arithmetic.
- supports RANDOM (up to 65,536 records) and SEQUENTIAL files.
- supports calls to FLEX9 (TM)
- one pass compiler allows overlays, program linkage and independent compilation of DATA and PROCEDURE DIVISIONS (for really BIG programs).
- local support, upgrade and maintenance to registered users.

Requires FLEX9 (TM), 56k and 1 disk drive.  
COBOL, MANUAL and demonstration programs, postage paid.....\$245.00.

Write to: "COBOL FOR FLEX9"

C/- J. Delforno,  
Lot 2, McGeorge Rd.,  
Gisborne South,  
Victoria. 3437.

## NEW

### MICROMASTER SBC \$495\*

A new complete single board computer specially designed for system integrators, OEMs, educators, and hobbyists.

- Z-80B CPU at 6 MHz
- 64K RAM
- Floppy disk controller for both 8" and 5" drives
- 2 Serial Ports
- Centronics printer port
- Clock calendar
- Hard disk adapter (optional)
- DMA controller (optional)
- Improved CP/M compatible op system.

Available as board only or as complete system.

- Introductory special plus sales tax.

Microtrix Pty. Ltd.

24 Bridge Street, Eitham. 3095  
(03) 439 5155.

**Sigma Data**  
also  
offer one  
of the  
world's  
best  
terminals.



## Qume

For more information and competitive prices on Qume printers and terminals and the comprehensive engineering and back-up services available, contact Sigma Data in Sydney on (02) 439 6211.

**Sigma Data offer Qume, the world's best letter quality printers.**



Stewart Roache Watson SDC 040.

# HUGHES Phototype

TYPESETTING BY TELEPHONE

FROM COMPUTERS  
OR WORD PROCESSORS  
DISK CONVERSIONS

CHEAPER • FASTER • ERROR FREE  
2/18A SPIT ROAD, MOSMAN, NSW 2088  
**960 2788**

## DEC RAINBOW SOFTWARE

**μT** — "The Rainbow Specialists" \$50  
**MBX** — Adds GSX Graphics, Screen Handling, Function Keys, etc. to MBASIC-86. \$50  
**μ-EDT** — Full Screen Editor. Both DEC EDT and WPS Keypad Layouts provided. \$50  
**TRILOGY I** — 3 real-time action games: DEATHRAY, METEOR, PHASORS \$40  
**TRILOGY II** — Coming soon: SHARKS, SNAKES, WORM  
Postage & Handling \$2.00 per order. For more information, send stamped self-addressed envelope to:  
**MICROCOMPUTER TECHNOLOGY**  
P.O. BOX 601, CHATSWOOD 2067

**Videoscope**  
Video Library Manager  
8 or 16 bit systems \$900

**PagePlanner**  
Typesetting on a microcomputer  
**EMZ80**  
Emulator to run CP/M-80 programs under CP/M-86 \$150

**Sanyo MBC550**  
RS232/RS422 serial cards \$135

Best Prices on: **Columbia, Fox, Kaypro, Logitech & Sanyo.**

**COMPUTER REALM PTY. LTD.**  
1/100a Young Street, Frankston 3199.  
(03) 29 2600 or (03) 781 4661

**CALL DAMIEN PRINS NOW FOR YOUR MARKET DIRECTORY ADVERTISEMENT.**  
(02) 663 9999.

**THIS SIZE FOR A LOW LOW COST.**



### 68000/6500 PRICES SLASHED

68000	6MGZ, 64 Pin Dip (8 and 10 Mhz Available)	AS\$28.80
65C02P-1	1MHz, Enhanced instruction set	9.90
65C02P-2	2MHz	10.89
6502A	CPU, 40 Pin, Clock, 64K	6.30
6511AQ	Single Chip Micro, CPU, RAM, 2MHz, RS232.	15.57
6541Q	Periph Controller, RAM, 23 I/O, Host Slave I/F Timer	10.26
6541AQ	2MHz	11.25
65C21	CMOS P/A	7.20
6522	VIA 40 Pin, two 8 Bit I/O Ports	5.04
6522A	2MHz	5.58
6532A	COM80 40 Pin, 2MHz	6.93
6545A-1	CRT Controller	10.35
6551	ACIA 28 Pin, SW Prog, Baud Rate	6.03
65C51	CMOS ACIA	9.62
6551A	2MHz	6.66
6592	Single Chip Printer Controller (for Epson Series 200 and 500 Printer)	10.35
2716	2K X 8 EPROM 450nSec	4.36
25-2732	4K X 8 EPROM	6.05
2764	8K X 8 EPROM	12.03
5213	2K X 8, 5V EPROM	27.00
QUIP 64	Socket for 6511Q and 6541Q	1.85
CRYSTALS	1 8432MHz, 2 00MHz	2.86
	32 768KHz, 3 686MHz, 8 00MHz, 12 00MHz	1.82

Plus Sales Tax, Postage and Pack (where applicable)  
Prepaid orders less 4%



Rockwell

P.O. Box 6502, Goodna Q4300  
BRISBANE — AUSTRALIA  
Phone: (07) 288-2455  
Telex: AA43778 ENECON

P.O. Box 12153  
Wellington North,  
Wellington, New Zealand

# DATATREE

The ultimate in micro workstations

Designed for the home and office, DataTree will bring your sprawling microcomputer system back into a self-contained unit. With separate levels for the computer and drives, visual monitor and printer, and storage for disks, manuals and paper. A rear catch-tray keeps printouts off the floor, and castors and folding side flaps allow your system to be moved from room to room.

Also available is our lower priced PC Workstation specifically designed for the top selling desk-top systems. Sturdy metal construction — no assembly required.



Contact the Data Decor dealer in your state, or



**DATA DÉCOR**  
Waterloo Place, Richmond.  
P.O. Box 357 Richmond, Vic. 3121. Tel: (03) 429 9488.

MELB: S.J. Bartlett: (03) 419 8855. SYD: Carmen Furniture Sales: (02) 221 1755. QLD: Computer Decor: (07) 369 5277. WA.: Datafurn: (09) 322 7022.  
S.A.: Elliservice: (08) 332 5077. A.C.T.: Carmen Furniture Sales: (062) 80 6466.  
TAS: Betabuy Ergonomics: (002) 23 4841.  
N.T.: SBA Distributors: (089) 81 8411.

DD 968

## WE PAY \$\$ FOR YOUR SOFTWARE

Send us your programme running on Cat/Apple, Challenger/IBM or VZ-200 and if suitable, we will pay top \$.

Many people have already made thousands!

Send to



Cnr Lane Cove & Waterloo Rds  
P.O. Box 321, North Ryde  
NSW 2113  
Telephone: (02) 888 3200

The company that's doing something about education

**LETTERS TO THE EDITOR:** We are happy to receive your comments and, if they are of interest to other readers, publish them. Letters will only be considered for publication if they include your name and address, although we can withhold such details from publishing on request. Note that we reserve the right to (and probably will) edit all letters for the sake of brevity, clarity or accuracy.

**SUBSCRIPTIONS:** Standard 12-issue rate within Australia: \$24. Surface rate for New Zealand and Papua New Guinea: \$32.60; airmail rate: \$41.60. Save more on two years' subscription: Australian rate \$42; surface rate to New Zealand and Papua New Guinea: \$59.20; airmail rate: \$81.20. Rates for other countries on application. All overseas rates quoted are to be paid in Australian dollars. Allow up to eight weeks for subscription processing.

**BACK COPIES:** and single issues are available from the publisher's office (\$2.50) or by mail (\$3). We will supply photostat copies of articles where a back issue is not available, at the single-magazine price for each feature copied.

**READERS' ENQUIRIES:** We will make every effort to answer readers' written enquiries, if accompanied by a stamped, self-addressed envelope, although staff shortages and deadline pressures may cause delays. Please include your telephone number(s) with any enquiry. Phone enquiries not related to subscriptions, readers' advertisements, or other 'service information' cannot be accepted.

**COPYRIGHT:** All material appearing in *Your Computer* magazine is copyright and cannot be reproduced in part or in full, by any means, without the written permission of the Publisher or Managing Editor. Computer clubs and schools can, however, apply for restricted permanent reproduction rights for non-commercial, limited-circulation use (for example, newsletters and class instruction). Given that it sometimes takes us a while to answer such requests, you can consider that restricted permanent rights apply in these cases from the day you send in your letter, and will later be confirmed (or withdrawn) by our reply.

**LIABILITY:** Although it is policy to check all material used in *Your Computer* for accuracy, usefulness and suitability, no warranty, either expressed or implied, is offered for any losses due to the use of any material in this magazine.

**EDITORIAL CONTRIBUTIONS:** Contributions to *Your Computer* are welcomed and will be given every consideration\*. Please read these notes carefully to get an idea of the style and format we prefer.

**All Contributions:** should include your name, address, and home and office phone numbers (in case we need to check details). Each page of your submission, and any material sent with it, should also carry your name.

**Contributions by Telephone:** Contributors who have modems and suitable software (in

the MODEM7/YAM mould - see our stories on Christensen Protocols in the May and June 1983 issues) can arrange direct transfer to our computers through our Bulletin Board system, which is on-line 24 hours a day, seven days a week. Contact our office by phone for details on transferring material in this way.

**Contributions on Disk:** Contributions can be accepted in a wide variety of disk formats, although some have to be converted outside our offices, which will add to the (often lengthy) delay between receipt and acknowledgement. The preferred medium is IBM standard format single-sided, single-density, 20 cm CP/M disks. We can also handle, in-office, Kaypro II and Osborne 13 cm disks, and 13 cm Apple DOS or Apple CP/M disks. If you have one of the formats listed by Archive Computer Services in Brisbane (usually advertised in this magazine), we can accept that too. Please pack them extremely carefully if

posting and label all disks with your name, address and phone number.

**Style:** All items should be typed (or printed) and double-spaced on plain white paper. We will only accept original copies - no photostats. Include your name, address, telephone number and the date on the first page of your manuscript (all manuscript pages should have your surname and page number in the top right-hand corner). Be clear and concise, keep jargon and adjectives to a minimum.

\*Although the greatest care will be exercised with contributions, no responsibility can be accepted for the safety or return of any letters, manuscripts, photographs or other materials supplied to *Your Computer* magazine. If return is desired, you should include a stamped, self-addressed envelope. If return is critical - say it's something you can't afford to lose - then don't send it; we are careful, but we're not perfect.

## AD INDEX

ACT Computers .....	OBC	Kenelec .....	YBC10
AED .....	118-119	Labtam .....	105
ANZ Books .....	102	Logo Manage. Info Centre .....	79
AWA .....	YBC16	Magraths .....	87
AWA Thorn .....	106-107	Market Directory .....	128
Arcom Pacific .....	5, 48	Microtrix .....	122
Automation Statham .....	96	Mitsui .....	92
Avtek .....	11	Moncreff .....	YBC2
Brother Industries .....	94	Mr Floppy .....	121
CAE .....	11	Multitech Computers .....	117
Cash & Carry Computers .....	46-47	Nashua .....	15
City Personal Computers .....	35	Nissel Sangyo .....	112
Colex .....	25	Output Media .....	125
Comm. & Prof. Micro .....	124	Ozisoft .....	IBC
Compsoft Micro Services .....	124	Pacesetter Peripherals .....	54
Computer Shield .....	16	Paris Radio .....	33
Computer Site Services .....	81	Pitman Publishing .....	115
Computer Spot .....	14	Portable Computer Co. ....	127
Conseltech .....	112	Qantem Audio Electric .....	109
Data Decor .....	129	Qubie .....	58
Database Management .....	30	RF Communications .....	33
Datatran .....	22	Robert Woodland Exhib. ....	112
Datron .....	89, 111	Rod Irving .....	18
David Glover .....	113	Roland .....	IFC
Dick Smith .....	76, 129	Ross Williams .....	12
Dream Disk .....	52	Sigma Data .....	56
Edusoft .....	13	Sigma Oki .....	42
Emona .....	110	Six S Business Advisory .....	108
Energy Control .....	129	Software City .....	53
Ferguson Transformers .....	116	Spacestation .....	121
Fujimex .....	55	Speedy Software Suppliers .....	117
Gambit Games .....	116	System Solutions .....	37
Hi-Tech Software .....	8	Telecom .....	28
Home Computers .....	117	Tetrad Systems .....	10
Ideas International .....	115	Think Computers .....	121
ImagIneering .....	3, 50	Uni Co-Op Bookshop .....	91
Intelligence .....	80	Warburton Franki .....	123
John Sands .....	100		

# UNLEASH THE MUSIC IN YOUR COMMODORE 64

SIGHT & SOUND  
Music Software, Inc.



## THE INCREDIBLE MUSICAL KEYBOARD

Now with no musical experience you can unleash the music that's hidden deep within your computer. This unique keyboard comes complete with its own software that will get you playing right away. It even includes two music books, one for the beginner, and one for the more advanced musician.

### KAWASAKI SYNTHESISER

This transforms your computer into a programmable synthesiser and sound processor. Use the polyphonic keyboard and preset sounds to create your own music. Unique three-track recording capabilities to produce an unlimited number of instrument sounds and special effects.

### KAWASAKI RHYTHM ROCKER

Create space sounds and hi-resolution colour graphics to the beat of electronic rhythms. This creative Music/Video synthesiser offers a variety of percussion and synthesiser sounds that can be laid down on top of pre-programmed bass lines.

### MUSIC PROCESSOR

Create, edit, record, play and compose your own musical arrangements. Use your joystick to change any of the 99 preset instrument and special effect sounds. Full music editor allows you to create new music or change one of the 16 pre-recorded tunes. See visual musical notation on the screen. Music Processor is compatible with the entire computer song album series.

### TUNE TRIVIA

Challenge yourself and your friends to music trivia from an almost infinite number of songs and questions. Four fascinating games in one, add your own tunes and trivia questions, try to stump your friends. Tune Trivia comes complete with superstar songbook and full documentation.

### COMPUTER SONG ALBUMS

Listen to the hits of Michael Jackson, Willie Nelson, Denise Williams, The Eurythmics, while you control computer generated instruments and special effects. Every musical arrangement comes complete with bass, rhythm, melody and harmony. Computer Song Albums are also compatible with the music video kit soon to be released.

# Ozi Soft™

AUSTRALIAN DISTRIBUTORS.

(02) 211-1266

### FUTURE 1984 RELEASES INCLUDE:

**Music Video Kit** - Make your own music videos with this powerful graphics processor. Paint a background scene, then synchronize your masterpiece to your music.

### 3001 Sound Odyssey

Travel through a complete tutorial on musical synthesis. Learn how subtle change in A.D.S.R., waveforms, ring modulation and filters work together, then create your own music.

AVAILABLE AT ALL GOOD COMPUTER STORES

# ANOTHER HARD ACT TO FOLLOW!

**act**

FIXED REMOVABLE  
WINCHESTER DISK SYSTEM

MADE IN AUSTRALIA



## Act's fixed removable disk systems give you MEGABYTES IN THE PALM OF YOUR HAND

### COMPATABILITY

No matter which micro you have, you can make it ACT. The ACT fixed removable winchester is compatible with most micros —

- APPLE I & IIE • COLUMBIA P.C.
- CORONA/WORDPLEX • DEC RAINBOW 100 • HEATH/ZENITH H89/Z89 • HITACHI PEACH • IBM P.C. • KAYPRO • MICROBEE
- MORROW MICRO-DECISION • NEC APC • NORTHSTAR ADVANTAGE & HORIZON • OSBORNE I & EXECUTIVE
- SANYO MBC-1000 & 555 • SIGMA/OKI MODELS 20 & 30 • SIRIUS • SUPERBRAIN I/II • TANDY II & III • TIME OFFICE
- TOSHIBA T-300 • XEROX 820
- PANASONIC JB-3001 • AND OTHERS.

### A GREAT STORAGE SYSTEM

Combine the best of two storage systems — the speed and capacity of a hard disk and the mobility of a floppy.

You can backup the days data, remove the disk and store it safely or carry it interstate in your briefcase — a great storage system!

### AUSTRALIAN

You don't have to pay more to buy Australian!

ACT is manufactured in Australia and supported by an Australian organisation committed to backup support and service. It's a professional ACT.

A DIVISION OF AUSTRALIAN PROTECTION INDUSTRIES

**act**

Australian Computer and Telecommunications  
75 Willoughby Road, Crows Nest, NSW 2065.  
Telephone 02 439 6300, Telex AA 24816

### DISTRIBUTORS.

Direct Data, 1065 High Street, Armadale, Victoria 3143. Telephone 03 20 6949.

Computer Mart, 356A King William Street, Adelaide, South Australia 5000. Telephone 08 51 5363.

# KIWISOFT™

GRAPHICS PROGRAMS  
for the Commodore 64.

## 1984 Catalogue



"Room"

PAINTPIC  
PICTURE



Available from:

**The VIC Centre**

416 Logan Road, Stones Corner,  
Brisbane, Australia.

P.O. Box 18, Stones Corner, Qld 4120

Tele: (07) 397 0888

STD (at local call charge only) (008) 777 130

(A division of CW Electronics)



PICTURE DISK 1: SPACE  
PICTURE DISK 2: FANTASY  
PICTURE DISK 3: PLANES  
PICTURE DISK 4: CARS  
PICTURE DISK 5: ANIMALS

### PICTURE DISKS

**\$29.00 ea** + p & h



10 detailed images on each disk to  
paint, print, or puzzle! Requires either  
PAINTPIC or PRINTAPIC or  
PUZZLEPIC.



One of ten  
Space Images



You make  
this picture!

### ORIGINAL ART DISK

A protected set of six original C-64 paintings,  
together with special display program. Includes  
ROOM, GIGO, HOLY LAND, QUO VADIS,  
STORM ON THE RANGES, and UNSTILL-LIFE.  
Available 30 Sept.

*"The Art of Daron J. Robinson"*

**\$59.00 + p&h**

### PUZZLEPIC™

Solve Mosaic, Exchange, and  
Joystick Maze puzzles. Four to 500  
pieces! Save intermediate positions.  
Years of enjoyment! Design your own  
puzzles too. Available 30 Oct.

**\$56.00 + p&h**

Pay in advance in Australian Dollars  
by cheque, money order, or via  
AMEX, Mastercard or Bankcard or  
Visa. Postage and handling extra.

Dealer Demonstration Disk Available **\$8.95**



# CADPIC™

"There's nothing like it!"

Computer-aided design  
for the Commodore 64

**\$89**  
on diskette

**CADPIC™ is  
PAINTPIC™ + PRINTAPIC™**

## PAINTPIC™

**\$49.95**  
on diskette  
+ p&h

"... a very capable package."  
— Creative Computing, February 1984

PAINTPIC is the BEST 16-color drawing program you will ever buy for your C-64. PAINTPIC provides easy drawing with the keyboard, joystick, graphics tablet, or track ball. Draw using a graphic pen, text characters, or one of 65,000 brushes. Let PAINTPIC do the work of filling any shape area with a color or even a brush.

Save parts of pictures to use in future pictures. You can put objects transparently on top of backgrounds. Automatic arcs, rectangles, tilted ellipses, triangles, lines, and parallelograms are provided. Automatic copy, mirror copy, rotate copy, half and double are there.

PAINTPIC provides a very fast, complete multi-color painting package for the C-64. It helps you use your PAINTPIC pictures in your own programs; and it allows you to convert pictures from other drawing programs and use them with PAINTPIC or PRINTAPIC.

## PRINTAPIC™

**\$49.95**  
on diskette + p&h

PRINTAPIC is the ultimate picture-printing program. A full set of five grey shades are used to accurately represent the 16 colors of the C-64 on a black-and-white printer. Additionally, the screened color separation prints feature of PRINTAPIC can be used to generate color printouts on black-and-white printers using color ribbons or colored carbon paper.

Teachers will find that the outline printing facility offers a new way to teach young children the use of color (give children crayons plus the Outline Print and let them look at the full color display). Plot printing is available to allow you to print silhouettes. PRINTAPIC provides complete support for hooked rug and tapestry designs: paint your own design with PAINTPIC, then print it with PRINTAPIC to get the pattern and the information on ordering materials.

PRINTAPIC works with most black-and-white printers and interfaces. The Commodore 1515, 1525, and MPS-801, all work directly on the C-64. The Grappler,™ Tymac Connection,™ Cardco A, and Cardco + G interfaces have all been used successfully with PRINTAPIC. Gemini and Epson printers or equivalents are supported through transparent mode on the Cardco A and Cardco + G to produce picture print times of about 13 minutes. A full PAINTPIC picture takes about 23 minutes to print on the 1525.

A camera data-input facility is included, for use with the Microneye™ camera. PRINTAPIC converts camera images so that they can be enhanced and colored with PAINTPIC and then printed with PRINTAPIC.

PRINTAPIC comes with the VENUS image by Velazquez in color, the Helicopter picture, the Gothic Alphabet, and a conversion program for pictures from other major drawing programs.



BLACK SCREEN

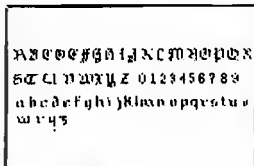

GOthic ALPHABET

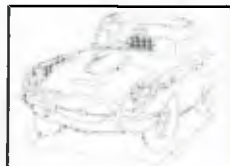

OUTLINE PRINT



VENUS by Velazquez. A PAINTPIC™ enhancement of a MICRONEYE™ camera image.

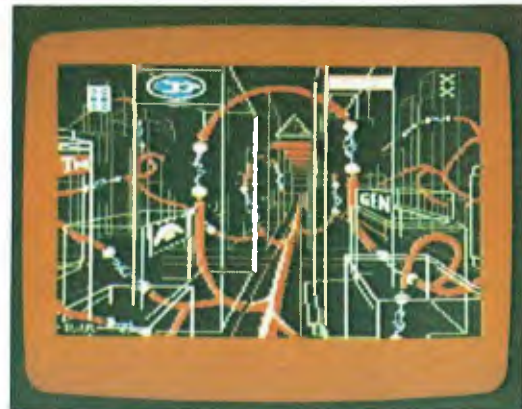

GIGO 1983 Kiwisoft Programs



PRINTOUT OF HELICOPTER



PRINTOUT OF VENUS



TAPESTRY & HOOK RUG