

# your computer

June, 1984.

**No.1**  
AUSTRALIA'S  
TOP-SELLING  
COMPUTER  
MAGAZINE  
AUDITED SALES

**\$2.50\* NZ\$3.00** MAGAZINE FOR BUSINESS AND PLEASURE

## WIN AN AUSTRALIAN-DESIGNED LABTAM COMPUTER!

### THE GREAT DATABASE SEARCH BEGINS

New Microbee  
Sirius goes to Market

Software and Hardware  
Reviews



### YOUR BUSINESS COMPUTER

Portables bring Business Home  
Business Applications  
ProKey, Friday Software Reviews



# THE BRAIN.

ONLY NEC COULD DO IT. The thinking businessman's personal computer. It's so smart we call it The Brain.

And if you want to get ahead in business all you need do is use your Brain.

It does things that are the envy of other personal business computer makers.

All for an extraordinarily competitive price.

It has 16 bit processing ability, that's just become the industry standard of comparison.

The NEC Advanced Personal Computer comes complete with both MS-DOS and CP/M-86 operating systems. It features advanced business processing capabilities with a wide range of application software available plus excellent communications and superb graphics in colour or mono. We believe it has no true competitors.

The NEC Advanced Personal Computer is very simply the "State of the Art" personal computer.

The Brain.

Use yours right now and arrange a demonstration to stay ahead of your competition.

Telephone toll free (008) 226344 (in Sydney telephone 4382322) or send the coupon below.

**NEC Information Systems Australia Pty. Ltd.**

**Sydney:** 99 Nicholson Street, St. Leonards 2065.

Telephone: (02) 438 3544.

**Melbourne:** 11 Queens Road, Melbourne 3004.

Telephone: (03) 267 5599.

**Brisbane:** 8 Campbell Street, Bowen Hills 4006.

Telephone: (07) 52 8544.

**Perth:** 67 Adelaide Terrace, Perth 6000.

Telephone: (09) 325 6988.



# NEC

NEC Corporation

Tokyo, Japan

*The NEC Advanced Personal Computer*



To NEC Information Systems Australia Pty. Ltd. (Inc. N.S.W.).  
Please send me more information about the NEC Advanced Personal Computer.

Name: \_\_\_\_\_ Company: \_\_\_\_\_

Address: \_\_\_\_\_ Postcode: \_\_\_\_\_

# NEC'S ADVANCED PERSONAL COMPUTER SOFTWARE

**BUSINESS SOLUTIONS  
AVAILABLE NOW.**

## Financial Modelling & Statistical Analysis

MICROMODELLER	MS-MULTI-TOOL
MICROPLAN	BUDGET
SCRATCHPAD-86	MS-MULTI-TOOL
SUPERCALC 86	FINANCIAL
MARS	STATEMENT
MS-MULTIPLAN	MASTERPLANNER
	ABSTAT

## Accounting

IMS (Ascent) & (Executive)	CARPE
DAVIDSON	SYBIZ
I.A.L.	PADMEDE
ATTACHE	AKKOUNTANT

## Industry Specific

Restaurant Accounting System	Insurance
Real Estate Management	Service Station
Management Simulation	Accounting
Taxation Preparation	Auctioneers
Swimming Pool Chemical	Newsagents
Retailing	Travel Agents
Medical Billing & Accounting	Smash Repairers
Video Rental	Builders
	Retail Stores
	Spare Parts Dealers

## Word Processing

BENCHMARK	SPELLBINDER-86
WORDSTAR 86	OK EDITOR

## Data Management

dBASE II	RESCUE
DATAFLEX	FMS-86
DMS-DELTA	FRIDAY
CONDOR-86	

## Graphics

AUTO-CAD	GRAPHWRITER
GRAPHPLAN	VIDEOGRAPH

## Operating Systems

MS-DOS	Concurrent CP/M-86
CP/M-86	UCSD p-System

## Programming Languages

Personal BASIC, RM COBOL, C BASIC 86, C B 86, PASCAL MII 86, Speed Programming Package for Pascal MII 86, CIS COBOL 86, DRIE 86, PL I 86,  
SSS FORTRAN 86, CONTROL C BASIC, SUPER SOFT C 86, PASCAL M 86, IANUS ADA 86, Computer Innovations C 86, MS-BASIC, MS-BASIC COMPILER,  
MS-BUSINESS-BASIC COMPILER, MS-PASCAL, MS-FORTRAN, MS-C, MS-COBOL

**PHONE TOLL FREE 008 226344  
(IN SYDNEY PHONE 438 2322)**

# NEC

FOR MORE INFORMATION ABOUT SOFTWARE FOR YOUR APPLICATION

NEC Corporation

## EDITOR

Jane Mackenzie

## CONSULTING EDITOR

Les Bell

## ASSISTANT EDITORS

Natalie Filatoff, Evan McHugh

## ART & DESIGN

Ali White

## ART PRODUCTION

Vicki Jones, Brian Jones

## MANAGING EDITOR

Jamieson Rowe

## CONTRIBUTORS

Australia: Brendan Akhurst, Bill Bolton, Lloyd Borrett, David Brudenall, Geoff Cohen, Andrew Farrell, Natalie Filatoff, Frank Lee, Evan McHugh, Mike Newnham, John Nicholls, Jeff Richards, Phil Scott, Rod Stevenson, Ernie Sugrue, Dom Swinkels, Bradley Thurkettle.  
United States: Howard Karten.

## ADVERTISING

Richard Pakalnis (Group Advertising Manager)  
David McDowall (National Advertising Manager)  
Mel Godfrey (Victorian Advertising Manager)

## OFFICES

### NSW

140 Joynton Ave, Waterloo 2017  
(02) 663-9999  
Telex: FEDPUB AA74488

### VICTORIA

150 Lonsdale St, Melbourne 3000  
(03) 662-1222  
Telex: FEDPUB AA34340

### WESTERN AUSTRALIA

Ian Greenacre, Gordon & Golch Adv t.  
134-144 Parry St, Perth 6000  
(09) 328-8044

### QUEENSLAND

Geoff Horne, Geoff Horne Agencies,  
16 Bellbowrie Centre, Bellbowrie 4070.  
(07) 202-6813

### SOUTH AUSTRALIA

Steve Birbeck, Admedia Group,  
24 Kensington Rd, Rose Park 5067  
(08) 332-8144

### NEW ZEALAND

Chris Horstley, 4A Symonds Court,  
Symonds St, Auckland NZ  
Telex: TEXTURE 260753

## OFFICE SERVICES

Cassie Bailey

**Source Mail:** Les Bell TCY314, Matt Whelan TCY267

**MiCC Bulletin Board:** (02) 662-1686 — Les Bell 1085, Matt Whelan 1, or leave a message in comments

**YOUR COMPUTER** is published monthly by the Federal Publishing Company Pty Ltd. Printed by ESN — The Litho Centre, Waterloo 2017, phone (02) 662-8888.

### Editorial and NSW Advertising:

140 Joynton Avenue, Waterloo 2017.  
Phone: (02) 663-9999 Postal address,  
PO Box 227, Waterloo 2017  
Telex: FEDPUB AA74488

**Publisher:** Michael Hannan.

Typeset by Hughes Phototype, Spit Junction NSW Phone: (02) 960-2788  
Distributed nationally by Gordon & Golch. Registered for posting as a publication — Publication No. NBP4384  
See back page for information on copyright, contributions, reader services and subscriptions

\*Recommended and maximum price only ISSN 0725-3931.

## FEATURES

### THE GREAT DATABASE SEARCH

22

*dBase II may be the most popular database management program around, but it does have its limitations. We start the search for the ultimate database.*

MATT WHELAN

### INNOCENCE REVISITED

43

*Last time Lesley Zolin wrote for this magazine, she was a beginner who hadn't even yet penetrated the mysteries of a disk drive. Now she gives a progress report to encourage others in the same situation to keep at it!*

LESLEY ZOLIN

### THIS LITTLE SIRIUS WENT TO MARKET

46

*When Widgee Shire Council installed a computer at its local cattle saleyards there were cries of protest from the conventionalists. However, now even the diehards are having to admit that computerisation is making the sales both fairer and faster.*

LEIGH & BARBARA HEMMINGS

### HIGH-TECH HEALING, PART 2

49

*Bionic limbs used to be the stuff of action movies, but now advances in both chip and computer technology are making them more and more part of everyday life.*

DR. EUGENE SHERRY

### OPTION-NOT-FITTED SYNDROME

56

*Eric Eulenstein flew one of the earliest Microbees around, and thought some of his early experiences could be helpful to other would-be apiarists.*

ERIC EULENSTEIN

### MICROBEE CASSETTE INTERFACE MODIFICATION

100

*Daniel Ford, Engineering Manager for Memory Products at Applied Technology, sent in these modifications to help anyone experiencing problems with saving and loading cassettes.*

DANIEL FORD

## TUTORIAL

### GETTING DBEST FROM DBASE, PART VIII

91

*In this issue, Les Bell covers macros — the most powerful yet most dangerous aspect of dBase.*

LES BELL

### GETTING FRIENDLY WITH BASIC, PART VI

105

*This month's tutorial deals with handling random access variable-length records in BASIC-80.*

JEFF RICHARDS

### RCPM NOTES

108

*Bill Bolton has been thinking for some time of writing a set of notes to help enthusiasts in setting up a remote CP/M system, but didn't know where to start! Finally he managed to get his thoughts on this complex subject down on paper in some semblance of order, and we'll present them to you at irregular intervals over the next few issues.*

BILL BOLTON

## REVIEWS

### A MICROBEE FOR BUSINESS?

36

*The Microbee has come a long way since its early kit days, and the latest offering in the range is a fully-featured system that could be used to run a small business.*

EVAN MCHUGH

### RITRON MONITOR

41

*If you're looking for a monitor that won't collapse your bank balance, this green or amber unit from Ritronics could be the answer.*

EVAN MCHUGH

### AMUST DT80 PRINTER

97

*If you ever wanted a printer that works as well as the Epson MX80 or C. Itoh Prowriter but costs a good deal less, the Amust DT80 could be what you're after.*

KEN OZANNE

## SPECIALS



### **GREAT AUSSIE SOFTWARE COMPETITION — WIN A LABTAM COMPUTER!**

**20**

You can win a computer and peripherals worth over \$14,000, plus other prizes, by writing the winning program in our Great Aussie Software Competition.

### **YOUR BUSINESS COMPUTER**



This month we look at the portable computers that are removing the barriers between work and home; discuss a building management system that can save you a third of your fuel costs per year; review two software packages — Friday! and ProKey; and reveal some unusual business applications of microcomputers.

## COLUMNS

VIC/C64	121
IBM-PC	124
HITACHI	126
CP/M	128
MICROBEE	135
TRS80 COCO	140

## DEPARTMENTS

YOUR COMPUTER NEWS	9
BOOKS IN BRIEF	55
CLASSIFIED ADS	142
MARKET DIRECTORY	144
SERVICES	146

## NEXT MONTH

In the last couple of years computers have started to play a larger and larger part in the creation and playing of music. The music industry has even succeeded in doing what no area of the computer industry has done: creating a standard interface — called MIDI — which allows all computer musical instruments to be connected together without difficulty. *Your Computer* takes an in-depth look at what's going on in this growing area of computerisation.

Also in next month's issue will be our usual features and reviews, plus the regular columns, news, and the bi-monthly edition of *Pocket Programs*.

# Getting the Best from Your Computer



Les Bell

AS TECHNOLOGY moves society more and more towards the 'convenience' solution to most problems, the latest panacea on offer to solve all one's problems, and at the same time relieve parents of the awesome responsibility of having to teach their children, is the personal computer.

Yet, if you examine the adverts for personal computers carefully, you'll find that almost nowhere do the ads promise you any kind of concrete benefit. While I can understand advertisers being somewhat vague about what a computer can actually do for you – there's not much to say for some models – what is becoming more and more intriguing to me is the way certain sections of the media are blithely leaping onto the bandwagon. There seems to be a conspiracy that magazines for people who have just bought a computer and don't know how to use it should be written by people in the same position (we understand the problems, we're on your side, and so on). This might be all right if the magazines in question have the technical back-up in their organisations to make sure they actually know what they're writing about, but how is the casual buyer to know whether that's the case?

While I'm on this subject, here are a few home truths.

The value of personal computers in the home is currently questionable, other than for satisfying personal curiosity about how computers work. Parents should not feel their children **must** have a computer; unless little Johnny is going to spend his adult life being chased around a maze while he tries to eat energy dots, the computers he will use then will bear about as much resemblance to today's home computers as a VK Commodore does to a Stanley Steamer. Nor will having a home computer help young Johnny to master the nuances of the sub-plot of Macbeth.

In the business world, things are better, but even then it is not simply a matter of plugging in the computer, slipping in a program disk, and watching it answer all the tricky questions your accountant asked you. You have to learn, first, the general principles of computer operation, then the specifics of a number of programs, and then how to specify your problem in a manner suitable for computer solution. None of this is trivial; it can sometimes be mind-bending, but then again, it can sometimes be extraordinarily rewarding.

Just about every magazine and newspaper has advice on how to buy a computer – such articles help to sell advertising (it's often instructive to match up the brands mentioned in an article with the nearby ads and then reflect on vested interests). Our interest, at **Your Computer**, is with what you do with your computer once you've unpacked it. We don't want to sell you a computer, because you've probably already got one. We do want to help you learn to get the best from it. We believe you'd rather learn how to get your own programs running than read about someone else's success, usually written in glowing terms by some public relations person anyway – or, sadly, by a journalist being paid to act like a public relations person.

That's what we're about – trying to help you to your personal success story with a computer by printing facts and advice, not publicity blurb for various products. We're not sure if all magazines can say the same. □

How to stay ahead  
of the pack.

# 10-NET™ takes the work out of networking. Everything you need is in the box.



Imagine being able to connect your PCs simply and inexpensively into a true full-function local area network.

Now you can . . . with 10-NET, a complete package designed so that you can easily install, learn and use it immediately. Everything you need to connect one PC into the network is included.

10-NET is uniquely different from other LAN products in that it requires no dedicated hardware to serve the rest of the network. It is a truly distributed system where your resources may be shared, including expensive hardware and application programs.

You can also share as much or as little data as you wish, with total data integrity and selective security.

You get built-in extras, too: like electronic mail; calendar; "Chat," a user-to-user communication facility; printer spooling; and "News," a bulletin board function for network users.

And, you can create a multi-user DBMS with unbelievable power and flexibility when you use 10-NET with 10-BASE, a powerful, easy-to-use DBMS designed specifically to work with 10-NET.

Invest in 10-NET now. You can start simple, and expand as your business grows. And you won't find better performance or value, anywhere.

Ask your software dealer for 10-NET, or call (03)347 7011.



#### 10-NET SPECIFICATIONS

##### HARDWARE:

PC plug-in circuit card, tap box, and cable to connect them

Type: Carrier Sense Multiple Access with collision avoidance

Speed: 1.0 million bits per second

Distance: up to 3,000 ft. between repeaters

##### SOFTWARE:

Share any DOS supported hardware device

No dedicated server required

Concurrency control—implicit & explicit

Security—User, File, Node ID

Ethernet compatibility—addressing & message format

##### SYSTEM REQUIREMENTS:

- IBM PC, XT or compatible
  - PC-DOS 2.0
  - 128K RAM
  - One or more disk drives
  - A cursor addressable monitor
  - Medium: simple twisted pair wire
- Specifications subject to change without notice

## FOX RESEARCH

A subsidiary of ComGen Technology, Inc.

Distributed in Australia exclusively by

**SCA SOFTWARE CORPORATION  
OF AUSTRALIA PTY. LTD.,**

449 Swanston Street, Melbourne, 3000.  
Telephone (03) 347 7011. Telex AA30458.



## Productivity tools for Australian business.



Announcing the  
University Co-op Bookshop



# Computer Book and Software Centre

INSIDE THE NEW SYDNEY TECHNICAL BRANCH  
RAILWAY SQUARE, 831 GEORGE ST, SYDNEY



**WIN**

An HP-150  
Touch-screen  
computer.

**PH: 211 0561**

*NOW OPEN SATURDAY*

Entry forms here.

*9 am — 12 noon*

**50 GREAT  
COMPUTER  
BOOKS**

AS ADVERTISED NATIONALLY  
*Available here*

**UNLIMITED STOCK**  
MEMBERS DISCOUNT AVAILABLE

**EDUCATIONAL  
SOFTWARE**

*See our growing range of  
Packaged Software*

- APPLE
- COMMODORE
- TEXAS INSTRUMENT etc.

ADVENTURE GAMES • BUSINESS PACKS

MEMBERS DISCOUNT AVAILABLE

**Texas Instrument  
Book  
Blowout!**

*The biggest range of  
titles ever assembled in Australia*

**YOUR LAST CHANCE**  
PERSONAL SHOPPERS ONLY

**Discounted  
Texas Instrument  
Software**

**A LARGE RANGE**

**OVERNIGHT DELIVERY OF ANY  
ITEM NOT IN STOCK**

CHECK OUR DISCOUNT TO  
MEMBERS AND NON-MEMBERS

## Some Interesting Morsels

THE YANKEE Group (the Australian subsidiary of the US research and consultancy organisation) has released figures which predict that 49,500 microcomputers for business systems will have been shipped to Australia by the end of 1984, and that in 1985 this number will rise to 76,000.

The undoubted leader among individual companies is, and will remain, IBM Australia, which is expected to bring in 10,000 micros in 1984 (if supplies permit) and 20,000 in 1985. Apple is placed second with 8000 in the current year and 10,000 machines in the next; while Tandy has third spot with 5000 in 1984 and 7000 in 1985. Sirius, Commodore, NEC, DEC and Wang are all expected to ship between 4000 and 6000 products next year.

The remaining figure comprising many other computers represents 14,000 deliveries in 1984 and a projected 21,000 in 1985. This implies that in spite of the dominant position of IBM, there is around one-third of the Australian market open to small entrepreneurs. Only Apple among the leading vendors is holding a substantial single share, ensuring a very competitive situation for the next year or two.

In a summary of the North American market, Dale Kutnick, director of research for the Yankee Group, forecast a rise in the use of portable computers which could be easily carried in a small bag or briefcase. He said the 'he-man-size', initiated

by the Osborne 1 and carried through lately into the IBM-PC portable, will decline — though the type will continue for another couple of years as these models are often also suitable as desktop personal computers.

Prices in all categories of portables are forecast to drop, with the notebook or briefcase-sized machines available from as low as \$US700, up to \$9000 for models with comprehensive facilities.

The trend will be for full-sized keyboards, and expansion from 40-character widths and 16-line depths to 80 characters by 24-line liquid crystal monochrome displays. Random access memory will commonly be 256K. Commercial applications software will be developed to fit into these machines through ROM modules.

Kutnick also said desktop model memories will soon increase from 256K to 512K internally, and the 16-bit machines will expand to 32-bit with one megabyte memories. Progress in these will be limited until the late 1980s due to a shortage in applications software for the more advanced hardware.

The bulk of new introductions are expected to be 'supermicros'. Powerful new semiconductor processors for these are currently under development and will probably be ready for release within twelve months.

If you'd like more information, contact the Yankee Group at 158 Avoca St, Randwick 2031. (02) 399 8200. □

## Lap of Honour in Hanover?

THE Hanover Fair, the world's foremost industrial show, was the scene of some spectacular new lap micros recently. Products like the Epson PX8 feature 32K ROM-stored operating systems and 64K RAMs with eight-line by 80-column liquid crystal displays. There is also a full set of on-board ROM and cassette-based software — and the whole lot costs a mere \$US200.

Another cheapie but far from nasty is the IS-II from Sord. It has an eight-line by 40-character screen and 60K of ROM-based operating system and integrated software.

Another impressive Hanover Fair product is the LBP-CX laser printer from Canon. It gives letter-quality print and will only cost \$US3500. □



## Fourth Draft

AUTODESK, an American software house specialising in computer-aided drafting (CAD) for microcomputers, has introduced the fourth revision of its AutoCAD software.

AutoCAD is intended for professional and precision drawing applications, including schematics, space planning, PC board design, mechanical drafting, architectural drafting, graphics design and freehand sketching.

The standard CAD features enable zooming, panning, copying, moving, rotating, erasing and development of drawing libraries.

The new release also incor-

porates: a 'break' command which permits partial deletion of drawing elements (for example, breaking an existing wall to insert a window); a 'cross-hatch' command which allows the use of user-defined hatch patterns; a free-hand sketch mode; fillets; automatic polygon close; arc/circle specifications; circular/radial arrays; alternative text fonts; and units in scientific, engineering, decimal, or feet and inches.

For more information contact the Australian distributor, Entercom Computer Co, 136 Bridge Rd, Richmond 3121. (03) 429 5883.

## File Transfer on the IBM-PC

A NEW package from Data Sat provides the IBM PC with automatic answering and disconnection and a file transfer utility. Data Sat's World Modem and Micro Stuff's Crosstalk XVI provide an intelligent communications terminal which can transfer files with error checking and

correction and password protection. Answering and disconnection can be automatic or manual using a simple menu-driven selection.

For more information contact Data Sat at Suite 5, 522-524 Kingsway, Miranda 2208, or phone (02) 525 6688. □



## Laser Optical Disk from Toshiba

AND the technology beat goes on. Toshiba recently revealed the Tosfile DF-2100R (not the catchiest of names), its new optical disk document storage and retrieval system.

The system stores up to 20,000 documents in random sequence on a disk the size of an LP record. The documents can then be retrieved at random, using as many as six parameters. Duplication for back-up is extremely easy.

The new technology is said to offer 500 hours of reliable continuous operation between service calls, with the average call being only half an hour. There have been around 200 installations in Japan in organisations ranging from manufacturing facilities to government and financial institutions.

For more information contact Toshiba, 84-92 Talavera Road, North Ryde 2113; phone (02) 887 3322.

## North Coast Computer Show

THE First North Coast Computer and Electronics Fair is happening this month, in Grafton. It will be held at Grafton's Rolla World Complex and will have around 60 exhibitors.

There are rumoured to be a few new products to be launched at the fair. People will be able to buy many of the products on display and there will be several special show promotions.

In the computer line there will be displays of hardware, software and games. There will also be representatives of the latest technology, robotics, demonstrated by 'Topo',

Futuretronics' Androbot. The electronics buffs will be able to check out the latest laser disc technology and home video systems. For the north coast's professional fishermen there will be a special display of marine electronics.

Admission to the show is \$2.00 for adults and \$1.00 for children, with special discounts for schools and colleges. It will be held on Friday and Saturday, June 22 and 23, from 10 am to 10 pm, and on Sunday June 24 from 10 am to 7 pm. For more information about the fair contact Big River Promotions on (066) 45 2892.

## Educational Software

ACTIVE Learning Systems has launched the first of a series of educational software products. 'One World' is a database on all the nations of the world for use by older primary students and secondary students, in the areas of geography, social studies, history and current affairs. It is also designed to develop analytical and computer skills.

One World's database contains information under 33 categories on the 178 independent nations of the world (as of January 1984). The information incorporates politics, physical geography, population and economy.

The program has been de-

signed to develop research and data interpretation skills and to encourage students to draw conclusions through analysis of relevant data. For example, they could research the extent to which natural resources affect the living standards of countries.

One World scans its database according to criteria selected by the operator (for example, percentage of urbanisation, literacy rate), then extracts and prints the information requested.

For more information on this and future educational software releases, contact John Perry on (07) 221 9640.

## News from Afar

FROM the Hanover (West Germany) trade fair has come the announcement that Commodore International is expanding its home and office range of personal computers. It has apparently displayed three 'pre-production' models which it will release in Europe before the US. These new Commodores are also likely to be released in Australia around the same time. Shipments are expected to start around the second half of 1984.

The lowest-priced machine

will be the Model 16 home computer, selling at around \$US100, with 16K of internal memory and program compatibility with the Commodore 64. For office use Commodore has announced an IBM-compatible transportable, to be made under licence with Bytec-Commterm of Canada (manufacturer of the Hyperion); and a 16-bit desktop unit with a Zilog microprocessor, designed to run a version of Unix.

## Electronic Banking System Launched

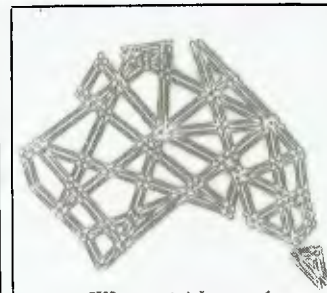

APRIL 1984 will go down in Australia's history as the month the first nationwide retail electronic funds transfer system went into operation. It was launched on April 9 by Mr Bob White, Managing Director of Westpac Banking Corporation.

Initially terminals will be installed in about 20 retail outlets. By early 1985 this will be extended to 500 Woolworths stores, all Food Plus convenience stores and about 450 BP service stations. Access will be through a Westpac Handycard, the new Westpac card or the Westpac Mastercard.

For more information contact your local Westpac branch.



### BBC Computer Education Resource Centre

A COMPLETE Resource Centre for educational computing requirements is now operating to provide teachers with evaluation software, books on educational computing, video tapes and hardware peripherals. A monthly newsletter is also available, free of charge, on request.

The Centre provides all the necessary information on the BBC micro, which is recom-

mended by education departments throughout Australia. It was set up by Microcomputer Systems of Sydney, a distributor of the BBC. A full catalogue, listing all resources for the BBC, is available from MCS.

For more information contact John Speed, MCS, 502 Miller St, Cammeray 2062, or phone (02) 923 1137. □

### Computer Images' New Slide Style

COMPUTER Images has devised a method for making business graphics slides available at a considerable saving. Called Simplislide, it gives the user a fill-in-the-blanks-style preparation guide to 221 of the most commonly used graphic layouts. Presenters just select the relevant master layout for each slide from the guide, fill in the blanks and send the order to Computer Images.

The benefits of the system are that the saving is an average of 40 per cent per slide, the presenter knows in advance what the cost will be, and he or she can design the slide without having to leave the office.

For further information contact Rob Matthews at Computer Images, Unit 3, Madison Place, 385 Pacific Hwy, Crows Nest 2065. (02) 922 7044. □

### Coy Computer

THE ARRIVAL of a new computer in Australia has received so little fanfare as to verge on conspiracy. The Compaq Portable Plus has features which include 256K memory and a total capacity for ten megabytes of data storage, a 20 cm screen, twin disk drives and the ability to run popular programs written for the IBM-PC and XT.

Released in the US last May, some sources have described the Compaq as the closest replica yet to the IBM-PC, without actually infringing IBM's copyrights.

In Australia, the Compaq will be sold exclusively through Computerland outlets.

For further information contact Computerland, 1-3 Rodborough Road, Frenches Forest 2086. Phone (02) 451 8899. □

## APPLETISERS

(Pardon the pun)

What a year it has been for the Apple range. The release of the Macintosh™ personal computer and the Apple IIc Portable computer has given Apple by far the finest range of personal computers.

City Personal Computers is Sydney's oldest Apple dealer with over 3 years experience. We are the only company offering the full Apple range in Sydney and North Sydney. A visit to one of our stores will save you all the wasted time and trouble that so many experience with lesser computer stores.

### Macintosh

The most innovative and exciting new computer since Lisa, but at only \$4,195 including printer and MacWrite/MacPaint software! We have all the latest software and accessories as they become available, such as Lotus 123, Microsoft Multiplan, Word, Chart and File, BASIC and Pascal, and literally *hundreds* more to come.

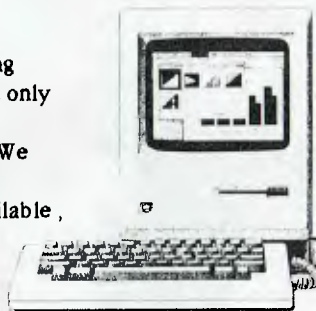

### Apple IIc

The Apple IIc Portable must be the most versatile computer ever. Use it in business, at home, in education or whatever - and take it everywhere you go because it only weighs 3.5 kg.

With built-in disk drive, printer ports and everything else you could need, and the enormous Apple II library to use, it will leave every other portable standing!

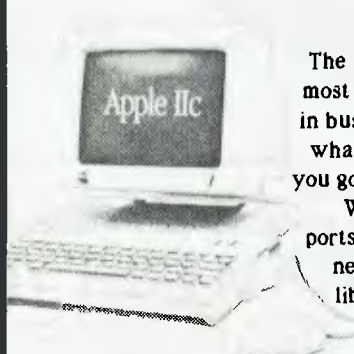

### Apple Lisa 2

There are now three Lisa 2 models, starting at just \$4,995 for a 512K system.

That gives you about 400K of model space in Multiplan and *must* be the best value on the market! The tremendous wave of software coming for Lisa includes the Unix operating system. Only one dealer in Sydney can really claim to be a Lisa

specialist and that's City Personal Computers - we've supplied more than most of the other dealers put together.

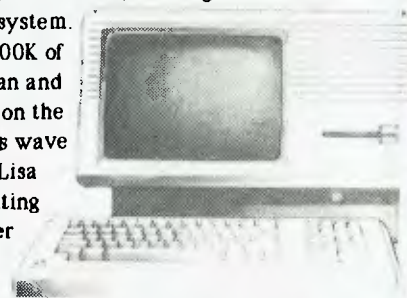

**CITY PERSONAL COMPUTERS**

SYDNEY  
55 YORK ST.,  
(02) 29-2461

NORTH SYDNEY  
100 MOUNT ST.,  
(02) 922-3600



## Computers Help the Disabled Communicate



A CAR accident victim, almost totally paralysed since 1981, has found a new way to communicate with the world using a Commodore computer. Marian McKellar can neither walk nor talk, and has only limited use of her right hand, but she can see and hear. A freelance computer programmer has devised a system using a Commodore 64 computer—donated by the local Lions Club—which allows her to communicate using only her right hand.

150 key sentences are programmed into the computer, and can all be accessed by the operation of a minimum of five keys. And what was the first message Marian spelt out? "My name is Marian spelt with an A"—all her medical records had Marion on them.

For more information contact Alan Lawson-Brown, the developer of the system, on (048) 21 2147.

## LOW COST DREAMDISK SYSTEM FOR YOUR MICROBEE.

**\$799  
INC. TAX**

The system that out-performs the others—

- 1. Versatile:** runs on any model MicroBee 16, 32 or 64k system running CP/M or our BeeDOS (Basic Disk Operating System).  
Drives may be single or double sided, and 5.25" or 8". Under CP/M (32 & 64k Bees), logical drive assignments are fully supported, giving single and multiple drive users best use of their systems. Our unique BeeDOS gives 16 & 32k machines full access to disks for storage of BASIC programs and data. WordBee files and machine language games.
  - 2. Power:** Up to 4 drives 8" or 5.25". Standard 40 track 5.25 inch drives give 390k of storage, the new 80 track drives give 790k, and 8 inch drives can give up to 1376k.
  - 3. Compatible:** with MicroBee disk system and many other CP/M formats. Our 80 track systems can read 80 and 40 track formats.
- |  |               |
|--|---------------|
| <b>DREAMDISK CONTROLLER</b><br>(controller card, all ROMS and manuals)   | <b>\$299</b>  |
| <b>COMPLETE SINGLE DRIVE SYSTEM</b><br>(includes controller, 40 track 5.25" drive, all cables, ROMs and manuals) | <b>\$799</b>  |
| <b>SINGLE 80 TRACK SYSTEM</b><br>(as above, but with an 80 track drive instead)                                  | <b>\$880</b>  |
| <b>DUAL DRIVE SYSTEM</b><br>(as for single drive system, plus another 40 track 5.25" drive)                      | <b>\$1050</b> |

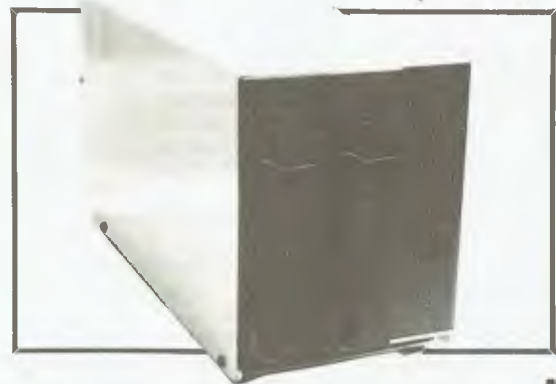

### DREAMDISK

171 Moray St. South Melbourne, 3205,  
Phone (03) 690 8283.



Write or Phone for more information:

## Computer Power for the Disabled

A NEW touch tablet, called the Powerpad, makes it possible for people who are unable to use a keyboard, joystick or light pen to use a computer. It has been released by Ashton Scholastic of Gosford NSW and cost \$199.

At present eight packages are available for it, with large plastic overlays which present menus that can be easily selected by simply touching them. The Powerpad works on Apple, Atari, Commodore and IBM-PC computers. The software starts at \$39.95. □

## Microbee Enhanced

MICROBEE owners will be pleased to know that the Enhancer 1 is now available. It has an inbuilt four-channel sound synthesiser and speaker and four joystick ports, and speech synthesis is also possible.

Two versions are available. The Enhancer 1 Version A suits the newer Microbees with the 1.5 amp rated powerpack, and costs \$139. The Enhancer 1 Version B suits the older 1 amp powerpacks. This cost \$149; both these prices include postage and packing, sales tax, subscription to the Vitronics quarterly, user manual and a demonstration program.

For more information contact Vitronics, 109 Lawrence Road, Mt. Waverley 3149. □

## First Kid on the Block

CANBERRA'S recently announced Technology Park has its first player. Hewlett-Packard has committed \$4 million to the construction of a large new office complex. The Technology Park is located close to the Canberra College of Advanced Education and National Sports Centre.

The Technology Park will also be able to take advantage of the resources of the CSIRO and the Australian National University. The park will accommo-

date community and private organisations involved in research, marketing demonstrations, servicing, manufacturing and assembling scientific and technological products. It will employ up to 5000 people. □

## Multimate Distributor

FOLLOWING our review of the Multimate word processing package in the February issue of *Your Computer*, the people at Software Corporation of Australia drew to our attention that they are the distributors for Multimate in Australia – and that we had neglected to mention it.

So, if you've been running around in circles trying to find out more about Multimate, we apologise; you can contact SCA at 449 Swanston Street, Melbourne 3000. Phone (03) 347 7011. □

## Decisions, Decisions

DECISION Analyst, a newly released program from Executive Software, is said to guide the user through the process of making complex decisions.

Distributed by Software City (PO Box 62, Blacktown 2148, phone (02) 621 4242), Decision Analyst is available for most 16-bit and 8-bit computers. It is claimed to make users clarify their thoughts and arrive at the right decision.

What we want to know is can it help us decide on where to have lunch in Waterloo. (*There isn't anywhere to have lunch in Waterloo – Ed.*) □

## Micro-to-Mainframe Link

A FINANCIAL applications micro-to-mainframe link for the IBM-PC is now available from SI Products, 55 Lavender Street, Milsons Point 2061 (phone 02 92 0811).

Called Smart Link, this new product can be installed in as little as 15 minutes and works with popular spreadsheets, including Lotus 1-2-3, VisiCalc and Multiplan. □

Now available, quality

# VIC-20 enhancements



**Make your VIC-20 talk. \$66.50**

The amazing Adman speech synthesizer. An infinite vocabulary, using the sound amplifier in your TV. Easy to use. Comprehensive instructions included. Major software houses have compatible games.



**Vixen 16K switchable RAM. \$79.00**

Full 16K, or 8K, or 3K, switchable into desired memory block. Use two with motherboard for 28K. Plugs into expansion port. Universal, runs any Basic program without readdressing.

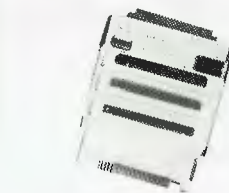

**Vixen switchable motherboard. \$65.00**

Up to 4 cartridges usable at the same time. Two rear positions power and memory location switchable. 4K ROM socket for extra firmware. Housed in custom protective case.



**Stonechip lightpen. \$39.95**

Draw and paint in colour on the TV screen. Save screen layouts on tape. Superb stability and resolution. Software included.

### Programmers aid.

18 new commands including renumber, autoline, sound, cursor XY, trace, block delete, paper, border, edit, etc. In fast machine code.

ROM (Needs motherboard) ..... **\$32.00** Cartridge ..... **\$47.00**

### Top VIC-20 games software.

Asteroids (unexp) .....	<b>\$19.95</b>	Jetpac (8K) .....	<b>\$17.95</b>
Chess (16K) .....	<b>\$23.95</b>	Paris (unexp) .....	<b>\$19.95</b>
Cosmiads (unexp) .....	<b>\$19.95</b>	Scramble (unexp) .....	<b>\$19.95</b>

Lots more for the VIC-20. Also enhancements for C64, Sinclair Spectrum and ZX-81. Send self-addressed envelope for catalogue.



**Robust joystick. \$29.95**

When you have thrown your other joysticks at the TV because of unreliable operation, it's time to get a Sureshot. Positive micro-switch action. For all Commodore, etc.



Australian distributor:

## dolphin computers

99 Reserve Road,  
Artarmon, 2064, NSW

Telephone: (02) 438-4933  
Telex: AA20677 HIDAUS1

Enquire at your local computer shop or mail order from Dolphin. Mail orders p&p \$5.00 Sydney, \$9.00 Australia, enclose cheque/money order. Bankcard details. All items guaranteed. All prices include Sales tax.

Dealer enquiries welcome.

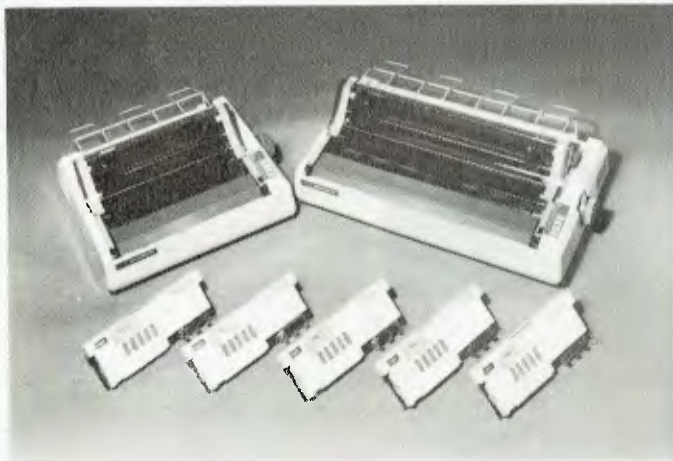

## Letter-Quality Dot Matrix Printers

NEC recently released the P2 and P3 Pinwriters. These new printers provide three modes of operation: a high print quality for correspondence and word

processing applications; high-density printing, which is of a little lower quality than that of the letter-quality, but operates at 90 characters a second; and the

third mode gives high speed (180 cps) for draft printing with the normal dot matrix quality.

The P2 and P3 also have a 'Font Select' button on the control panel, which allows the user to easily select any of eight font styles and speeds, including down-load fonts stored in a separate memory.

Optional snap-on pinfeed tractors are available. Alternatively, a simple cut sheet guide will allow the operator to load single pages as required using the built-in semi-automatic sheet feed capability of the printer.

The P2, which accepts 12 cm to 25 cm wide paper, costs \$995 plus tax; the P3, which accepts 13 cm to 40 cm, costs \$1250, also plus tax.

For further information contact NEC, 99 Nicholson Street, St Leonards 2065. Phone (02) 438 3544.

## In NEC Context

NEC made a second major release recently in the form of Context MBA, an integrated business software package for its Advanced Personal Computer.

The program, which was designed for managers and professionals, claims to combine spreadsheet, graphics, database management, word processing, telecommunications and forms creation functions.

A spokesman for APC said, "Using this one package, information may be filed in a database and retrieved when required; that data can be analysed using the spreadsheet and in a graphic form, and a final report be prepared with the word processor - and com-

## WORD-PROCESSING ?



## ASSEMBLING ?

\$95  
p&p free

Here's real power at low cost !

### WORD-PROCESSOR: ★ Simple to learn. Simple to use.

- ★ "Swapping" version for 48K Apple II Plus;
- ★ "Enhanced" version for 64K II Plus and Apple //e; appropriate version automatically loaded at boot-up.
- ★ Compatible with full //e keyboard; makes use of all keys including arrows and "open-Apple".
- ★ No extra hardware needed, (16K card an advantage) yet you get upper and lower-case on screen.
- ★ 55 characters/line on screen (printing to any number).
- ★ Totally menu or prompt-line driven: your options always clearly displayed.
- ★ Key-letter commands (press F for Find, D for Delete).
- ★ Upper and lower case from keyboard, with temporary-upper-case and upper-case-lock; recognises standard shiftkey modification and enhanced keyboards like that on the Apple //e and Apple-compatibles.
- ★ Features a type-ahead buffer and allows insertion of characters like \ [ ( ; ) and all control characters; printer control sequences are simple!
- ★ Full, easily-varied formatting of printed output includes page headings, indentation, autospacing, right- and center-justification, use of definitions.
- ★ Has Preview mode for viewing the final format.
- ★ Includes a Mailer system with selective mailing.
- ★ You can even insert pictures in your text!
- ★ Clear 95-page manual includes tutorial for Editor.

### & ASSEMBLER: ★ Fully integrated with the complete word-processor.

- ★ Super fast (250 lines of source in just 9 secs!).
- ★ Assembly errors can be corrected immediately by returning to the offending line in the editor.
- ★ Uses standard Apple 6502 assembly language.
- ★ Assembler would be great value alone!

→ PURCHASE or DETAILS from: **SAPICIFIC SOFTWARE**

**FULLTEXT :: 55**

P.O. Box 468  
Epping, NSW, 2121

## 14 FREE PROGRAMS

with each G-Pascal Compiler purchased on disk for the Commodore 64. \*

- DEMO - G-Pascal demonstration program.
- SUB HUNT - example arcade game (joysticks, paddles or keyboard).
- MODEM64 - data communication program.
- ADVENTURE - Pascal adventure game.
- SPRITE EDITOR - create sprite shapes easily!
- SOUND EDITOR - experiment with the synthesizer chip.
- RUNTIME - create stand-alone programs written in Pascal.
- CENTRONICS PRINT - print G-Pascal programs via parallel port.
- BITMAPPED TEXT - mix text and hi-res graphics!
- NUMBER GAME - a simple Pascal game.
- PRIME NUMBERS - calculate prime numbers quickly.
- PAINT SINGLE - 'fill in' landscapes quickly in single colour hi-res.
- PAINT MULTI - 'fill in' landscapes in multi colour hi-res graphics.
- WORD WRAP - wraps words around at the end of the line.

All of the above programs are supplied free with each purchase of G-Pascal on disk. G-Pascal is available from your local Commodore dealer, Commodore Information Centre Pty. Ltd., or Gambit Games. Recommended retail: \$79.50

\* excludes existing older dealer stocks.

If you have already purchased G-Pascal these extra programs may be ordered by sending \$20 direct to Gambit Games.

**Gambit Games**

P.O. Box 124, Ivanhoe, Vic 3079  
Phone: (03) 497 1283.



welcome here



munications capabilities are available when you need them."

Context MBA costs \$884 (including tax). For further information, contact NEC. □

### TI 99/4A Support

IMAGIC Australasia has decided to support the TI 99/4A in

Australia, and will undertake marketing and distribution for software and peripherals. The support agreement means that Imagic will have sufficient material to support the system for three years.

According to Managing Director of Imagic, Chris Milner, "TI owners can look forward to extensive support for the life of their computer." For more information contact Imagic Australasia, PO Box 234, Dee Why 2099; phone (02) 981 2744. □

### Computers Wiped Out

BONELLA Pty Ltd recently displayed its range of computer cleaning products in our offices. The range is the biggest available from one manufacturer and with many soiled and dirty computers in just as many offices, their market is very large.

Products available include Computer Cleaner for polishing and leaving an anti-static surface on computer exteriors, a light scratch remover, anti-static carpet spray, ballpoint pen ink remover, platen prep conditioner and cleaner, Cleantype daisywheel cleaner, lint-free disposable wipers, Gum-Off (for the removal of adhesives) and a kit containing the best of all these products.

For more information contact the distributors: Bonella, 790 Pacific Highway, Gordon 2072, or phone (02) 498 6241. □

### Internal Apple Modem

NETCOMM Australia has released its wholly Australian-designed and built multi-function modem for Apple computers. The modem features auto dial, answer and disconnect functions. It operates at 300 baud ▶

## PUBLIC ACCOUNTANTS

- ★ Client Write-up
- ★ Tax Lodgements & Tax Return Covers
- ★ Time & Disbursement Costing
- ★ Bureau Debtors/Creditors

At last, quality software for your IBM PC, ABC 24 & 26, Discovery, Apple, Sirius, Kaypro, Osborne, NEC, Apricot, Sanyo, Xerox, I.M.S., Archives PC, Amust, Vector, DEC Rainbow, etc.

Designed by accountants for accountants, with over 45 users throughout Australia. Fully integrated with word processing (WordStar, Spellbinder, etc.) so final accounts are prepared in a single step. Simple to use.

The Australian describes the write-up software as 'clear and versatile.' A user writes 'Thank you for such problem free software. Since we purchased it everything has run very smoothly indeed.' Talk to these satisfied users:

John McMahon  
John Davies & Ass.  
Coffs Harbour  
(066) 52 3522

Rob Renting  
R.J. Murphy & Co.  
Perth  
(09) 362 4716

Dennis Rynn  
N.K. Meredith & Co.  
Brisbane  
(07) 398 9633

B. Brooks  
Bernvale Nominees  
Sydney  
(02) 487 2832

**The Automated Office Pty. limited, P.O. Box 490, Chatswood. 2067 (02) 411 1892.**

#### Available from

NSW John Smith - Archives Computers 922 3188, Mike Wilson - MCC Consulting 356 3360, Mike Kuhn - Bisplan Consulting Services 419 7822, Terry Curtis - Data Parts Albury (060) 21 8080

VIC Jerry Pokolk - Archives Computers 699 8377, Mike Dewhirst - S.I. Microcomputer Systems 267 5877, Noel Morley - Data Parts Shepparton (058) 21 7155, Ern Kraulis - Data Parts Bendigo (054) 43 4866, Lee Mullin - Data Parts Ballarat (053) 31 3399

QLD Julie Ridgeway - Ventec Computer Pty. Ltd. 391 6722

W.A. Michael Henry - Computer House 362 5088, Mark Foley - Co.Worker 362 4650.

**TOP SELLING AUSTRALIAN COMPUTER**

# Coming to terms with the future

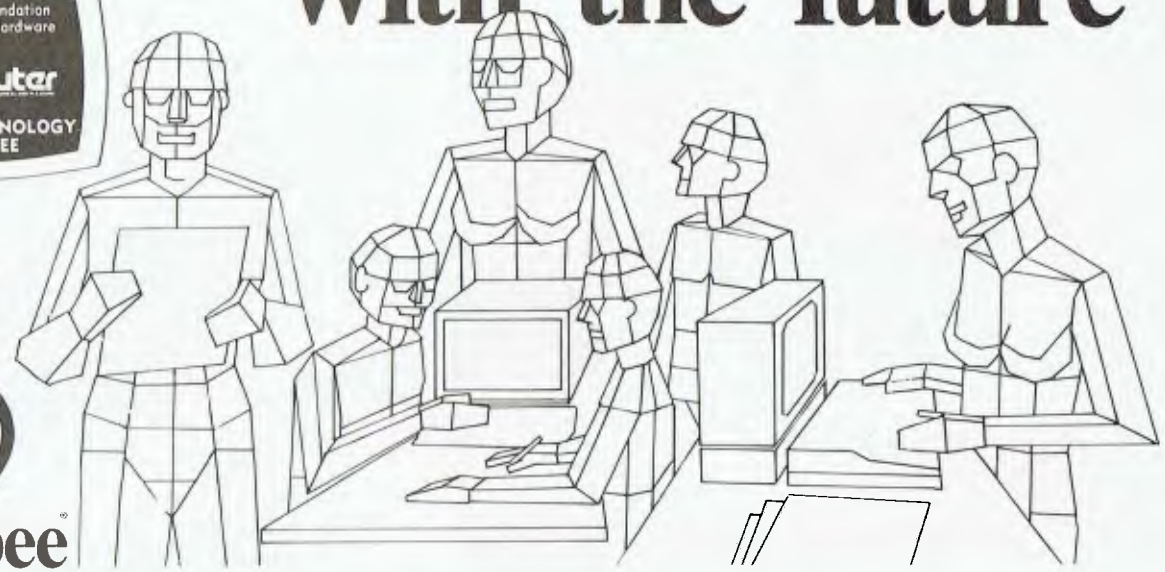

## Education

**microbee** is now officially recognized as Australia's Educational Home Computer. With the release of BEENET 2 it is now possible to NETWORK 16 or more **microbees** in a classroom with each student station linked to the teacher's file server to produce the ideal classroom system sharing printers, disk drives and rapidly transferring information as required.

## Personal Business Use

People don't only want to just *use* a personal computer. Computers are

for doing something useful in the world. Man uses TOOLS to achieve his goals. **microbee** recognises this and provides Wordprocessing, Communications, BASIC and a host of utilities inside each unit. In all cases **microbee** is being used as a TOOL in the service of mankind.

## Family Entertainment

Not all applications need to be so serious. **microbee** is ideal as a basis for exciting and stimulating games for all the family. Fast moving graphics, sound effects and over 200 top quality popular games mean your **microbee** is ideal for family fun as well.

Why not try your hand at Micro Space Invaders, Robotman, or play Bee Monopoly the 1984 way. Think you know a lot about chess? Try your skills against **microbee** . . . it can also show how to improve your game . . .

## Personal Finance

**microbee** is a powerful calculator and can be used to improve your personal financial planning, start a data base or even schedule your appointments. **microbee** is indeed a modern tool for today's times, enabling young and old to come to terms with the future in a constructive, informative and entertaining way.

### SERIES 2

## EXPERIMENTER

By popular request, the low cost **microbee Series 2 Experimenter** has been designed for those who are starting out in the fascinating world of computers or those who want to share the fascination of exploring the exciting developments in the fast moving MICROWORLD. All **microbees** can be expanded at any time.

**microbee Experimenter** . . . . . \$399

### SERIES 2

## EDUCATOR



The **microbee Series 2 Educator** was specifically designed to serve the needs of the education market. This is recognised by the fact that the **microbee** has been chosen by the NSW, WA, Queensland and the Australian Schools Commission as a recommended computer for use in schools. With the exceptional performance at a realistic price, powerful software designed for Australian curriculum needs, **microbee** is now in wide use throughout primary, secondary schools, technical colleges and universities.

**microbee Educator** . . . . . \$449

### SERIES 2

## ADVANCED PERSONAL COMPUTER

The **microbee Series 2 APC** with 500K Disk Drive is the most powerful and best priced/performance computer in its class. The APC is now supplied 'bundled' with WORDSTAR, MULTIPLAN, **microbee** BASIC, CPM 2.2 plus MICROWORLD packages such as disk WORDBEE, EDASM, BASIC as well as vital utilities such as CONFIG, FORMAT, COMPARE. Comprehensive Microworld User Manual also supplied.

**microbee APC** (Single Disk Drive) . . . . . \$1495  
**microbee APC** (Dual Disk Drive) . . . . . \$1795

# The Solution: microbee Personal Communicator

Our top selling portable microbee, the Personal Communicator now features Telcom1 firmware, WORDBEE, Microworld BASIC, machine code MONITOR, ADM-3A terminal emulation, self-test in 28K of ROM with 32K of CMOS battery backed user memory, high resolution PCG GRAPHICS, SERIAL AND PARALLEL I/O ports, programmable cassette interface, and direct monochrome video output.

Add the low cost BEEMODEM and your Personal Communicator uses the home telephone line to become a complete home terminal ready, willing and able to communicate with other computers worldwide.

Microworld BASIC has long been a powerful feature of the microbee. A vast library of educational, entertainment and utility software is now widely available on the market. Microworld BASIC supports full high resolution graphics, colour if required, music, I/O data can be directed at will and, best of all, MW BASIC is a breeze to learn to program yourself.



microbee Personal Communicator... **\$499**

## microbee computer centres

1 Pattison Ave,  
Waitara 2077.  
Phone (02) 487 2711  
729 Glenferrie Rd,  
Hawthorn 3122.  
Phone (03) 819 5288  
141 Stirling Highway,  
Nedlands, Perth.  
Phone (09) 386 8250  
Coolman Court,  
Weston A.C.T. 2611.  
Phone (062) 88 6384  
151 Unley Road, Unley,  
S.A. 5061. (08) 272 1384  
455 Logan Road,  
Stones Corner,  
Qld 4120  
Koala Crescent,  
West Gosford 2250.  
(043) 24 2711

Authorised Dealers in:—  
**NSW:** Carlingford,  
Coffs Harbour, Concord,  
Hurstville, Lismore,  
Sydney, Waterloo,  
Wauchope  
**VICTORIA:**  
Glen Waverley,  
Melbourne,  
Milton.  
**QUEENSLAND:**  
Aitkenvale, Cairns,  
Milton.  
**SOUTH AUSTRALIA:**  
Adelaide, Edwardstown,  
Port Lincoln.  
**WESTERN AUSTRALIA:**  
Mount Tom Price.  
**TASMANIA:**  
Launceston  
**ACT:**  
Belconnen, Weston.

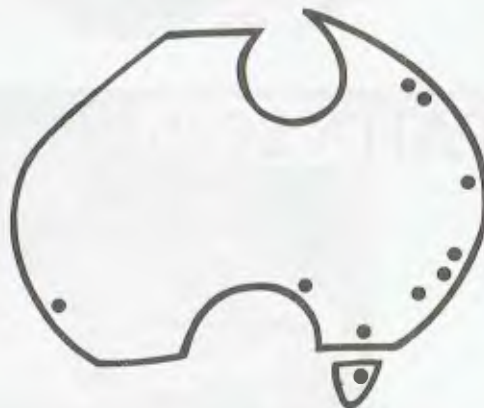

Shops and Dealers  
Australia wide

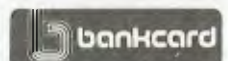

welcome here

DIRECT ORDERS  
PHONE (02) 487 2711  
TELEX AA72767

APPLIED  
TECHNOLOGY  
RETAIL PTY LTD



microbee

asynchronous full duplex, 1200 baud synchronous and 1200/75 baud asynchronous, which gives it the ability to access a wide range of systems.

Netcomm will supply the Apple-based software package under a third-party developer's licence to allow the routines to be integrated into application packages. Demonstration programs are available that fully utilise the modem and show its range of facilities. The cost of the product is \$495.

For more information contact DataNetComm, 8/33 Ryde Rd, Pymble 2073. (02) 498 5577.



DataNetComm's modem for Apple II and IIe models.

## Real Sound Processor for Apple

AUSTRALIAN company Thinking Systems has obtained sole distribution rights to a new sound processing board from US company Decillionix. The DX-1 uses a high-speed analogue-to digital converter and supplies a range of software to speed up, slow down, play backwards, forwards and sequence sounds in any way.

The system requires a 48K Apple II or IIe running DOS 3.3 and Applesoft BASIC. It costs \$320. For more information contact Thinking Systems, PO Box 260, Cammeray 2062, or phone (02) 90 6868.

## TICLIP Portable Printer

THE TICLIP, Texas Instruments' 'smaller than a briefcase' printer, has been released in Australia by Datatel Pty Ltd. It's really called Model TI703, but it weighs only 3 kg and is useful when used with an acoustic coupler and telephone to call up the computer at work.

Being a thermal printer, its operation is virtually silent, and it is battery or mains operated. It prints at 45 characters per second, has single key log-on, an additional RS232 port for direct connect, and a normal typewriter-compatible keyboard. The TICLIP is Telecom approved.

For more information contact Datatel, 19 Raglan St, South Melbourne 3205. Phone (03) 690 4000 or Sydney (02) 439 4211.

## Single-Board Computer

THE AMPRO Little Board is a recently released miniature single-board computer. Small enough to mount directly on a 13 cm mini-floppy disk drive, the Little Board combines a 4 MHz Z80A CPU with 64K RAM, two RS232 ports, a parallel printer port, disk controller, the CP/M 2.2 operating system and utilities.

The disk controller will operate with 40-track and 80-track drives, single and double-sided, single and double density disks. Utilities are provided to read and write the disk formats of other computers.

For more information, contact ASP Microcomputers, PO Box 259, Caulfield East 3145. Phone (03) 500 0628.

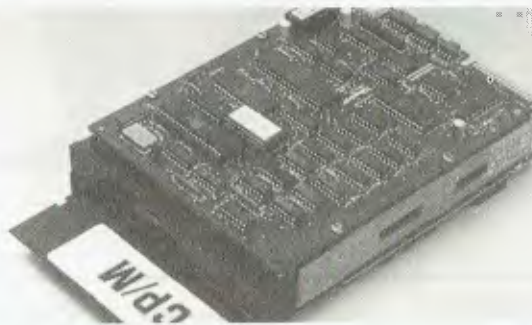

## HP Inkjet Printer

CALLED the Thinkjet, the new HP inkjet printer offers high-quality, high-speed, silent printing. The printer has just been announced in the United States and features connection to all the HP range and the Apple II, Compaq, IBM PC and Texas Instruments computers.

The printer operates at 150 characters per second, has a footprint no larger than a sheet of paper and weighs between 2.5 kg and 3.5 kg. The ink supply is contained within the print-head, and when the ink runs out it is simply replaced; each printhead is said to be sufficient to print 500 pages of text. For more information contact your local HP outlet.

## INTRODUCING COMPAT

THE ALL NEW professionally designed WORKSTATION for your PERSONAL COMPUTER and its PERIPHERALS, featuring:

- \*unique slide-out keyboard/desk
- \*good keyboard and monitor height
- \*combined flap & manuals/notes rest
- \*internal four point power socket
- \*rear wiring port; removeable legs
- \*quality flap stay & desk runners
- \*CHOICE OF FINISH: white, beige, pine, teak, or walnut melamines

desk only: **\$225**



h:310  
d:590  
w:900mm

## SPACESTATION COMPUTER FURNITURE

414 STIRLING HIGHWAY, COTTESLOE, WESTERN AUSTRALIA  
POSTCODE: 6012 PHONE: (09) 384.8499

delivered **FREE** ANYWHERE IN AUSTRALIA

NAME \_\_\_\_\_  
 ADDRESS \_\_\_\_\_  
 CITY/TOWN \_\_\_\_\_  
 STATE \_\_\_\_\_ PHONE \_\_\_\_\_  
 QUANTITY ( ) FINISH \_\_\_\_\_  
 Signed: \_\_\_\_\_  
 Cheque ( ) Bankcard ( ) Visa ( )



**IMAGINEERING<sup>TM</sup>**

"The Art of Software"

*presents*

## **THE TIME SPECTRUM<sup>TM</sup>**

**"ADD UP TO 512K RAM, ASYNC AND SYNC COMMUNICATIONS, A CLOCK AND PRINTER SUPPORT-UP TO FOUR I/O PORTS IN JUST ONE SLOT."**



**PERSYST<sup>TM</sup>**

Available for the IBM PC & XT at all fine microcomputer outlets  
IMAGINEERING, 579 HARRIS STREET, ULTIMO, N.S.W. 2007. TELEPHONE: (02) 212 1411

# The GREAT AUSSIE SOF

The Labtam 3006 is an Australian-designed and built microcomputer that meets the highest specifications and requirements. It was originally built by the company for its own use in scientific applications, but proved to be such a top performer that other companies wanted the chance to use it — so Labtam started building them commercially.

You can win a Labtam 3006 plus many extras, worth a total of over \$14,000, by entering the Great Aussie Software Competition.

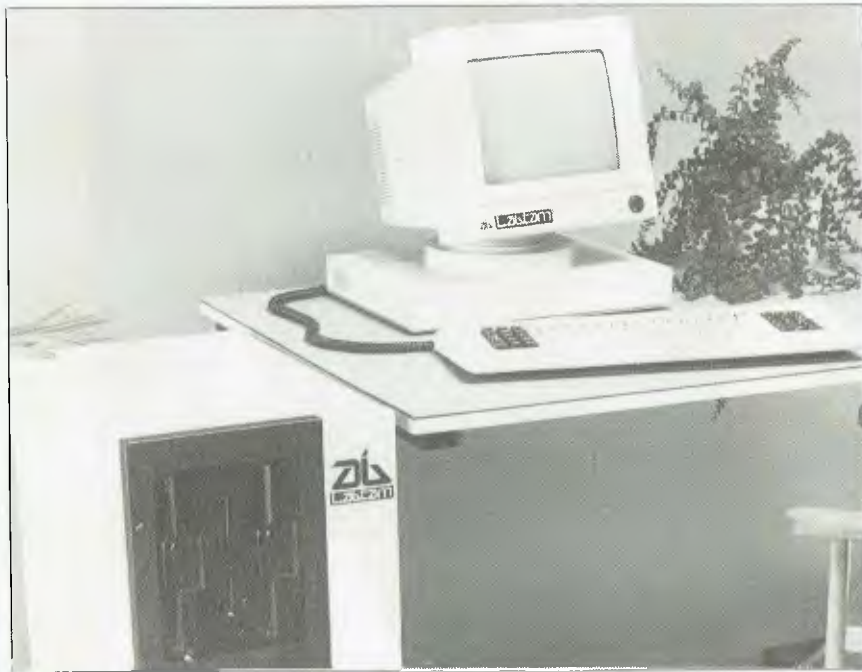

## The Prize ★

The winner of the Great Aussie Software Competition will receive a model 3006 floor-standing Labtam computer, including a 15-slot IEEE-796 multibus motherboard and switched mode power supply.

Included within the cabinet is a Z80A CPU running at 5 MHz with 128K RAM, and an Intel 8086 CPU running at 8 MHz, also with 128K RAM. Labtam is also supplying an extra 128K of RAM, bringing the total to 384K.

CP/M-86 for 16-bit operation and CP/M 2.2 for 8-bit operation are included, as well as MS-DOS. Labtam is also giving the winner copies of Wordstar Professional and Supercalc 2. Battery back-up is supplied for the real-time/date clock and time counter.

The desktop console is Labtam's own high-resolution terminal and keyboard, which enables the provision of REGIS graphics. Storage on the system is via a 20 cm floppy disk drive providing 1.2 megabytes of storage, plus a Winchester disk drive with 10M.

To complete this outstanding computer system, Anderson Digital Equipment has donated a **Mannesmann Tally MT 160 printer** to provide output from the machine. The MT 160 is a high-resolution printer with graphics capability, and prints at 160 characters per second.



## RULES

1. The program should be in a language compatible with CP/M 2.2, CP/M-86, MP/M-86, MS-DOS or IDRIS. In the event that a program is submitted under MS-DOS, it **must not** be hardware dependent (i.e. IBM-PC).
2. The program must be submitted on an IBM-compatible, single-sided, single density, 20 cm diskette, or an IBM-compatible (under the above operating systems) 13 cm diskette.
3. A short written resume of the program should accompany the entry, and it should be in a printed listing or typed form.
4. All entries must be accompanied by an original coupon from 'Your Computer'. The coupon must be signed, and in the case of a joint effort from, for example, a company, the signature must be by someone authorised to sign on behalf of the company.

5. The judges' decision is final and no correspondence will be entered into over the competition, nor any interviews granted.
6. No employees or relatives of the Federal Publishing Company Pty Ltd, Eastern Suburbs Newspapers Pty Ltd, or Labtam International Pty Ltd, their advertising agencies or associated companies, are eligible to enter.
7. The competition will run in 'Your Computer' for four issues from June to September 1984 inclusive, and entries will close by the last mail received on September 30, 1984.
8. Entries which do not comply with these conditions, including entries received after the closing time, will be disqualified.
9. All entries, whether disqualified or not, will be returned to the appropriate participants.
10. The winning program remains the property of the author for him or her to use and apply as

desired.

11. The prizes in the competition have no monetary refund value, are not transferable, and cannot be substituted or varied.
12. The competition will be judged by a panel of experts, which will use its best endeavours to see that every entry is properly considered.
13. Any omission to consider any entry and/or error by the judges or by any representative of Labtam International Pty Ltd or Federal Publishing Company Pty Ltd shall not invalidate the competition or give rise to any rights in any competitor to take proceedings against either of the promoters of the competition or any officers or employees of either of these companies at law or in equity on any account.
14. All competitors taking part agree as a condition of entry to accept the judges' decision as final and binding.

# SOFTWARE COMPETITION!

All you have to do (all! we say) is write an original, innovative and useful program for any application you choose, and send it in to *Your Computer* for evaluation. Our panel of judges will whittle the entries down to a short list, and then subject these shortlisted finalists to a thorough scrutiny and workout.

Our judges are all people well experienced in the world of programming: Les Bell, founding editor and now contributing editor of this magazine, and a well-known software consultant in his own right; Matt Whelan, former Managing Editor of *Your Computer* and now head of this publishing company's EDP department; and Dr Barry Thornton PhD, DSc, dean of the Faculty of Mathematical and Computing Sciences at the New South Wales Institute of Technology. Dr Thornton is also Chief Executive Officer of the Foundation for Australian Resources — which he set up nine years ago — and was Technical Director and General Manager of Honeywell for eleven years.

## Format

We'd like to be able to test your programs on a Labtam computer, so here's some information about its specific escape sequences and so on.

A Labtam terminal behaves like an ANSI-standard terminal, or alternatively can use VT52 cursor positioning escape sequences. The people at Labtam have also implemented a subset of the DEC REGIS graphics set, although they warn

that they haven't incorporated all the more intricate options.

If you'd like more details about the Labtam escape codes, write to us and we'll send you a photocopy of the actual manual — we just don't have enough room here to list them all. However, if you follow the above standards and don't go into the intricacies of various subsets, Labtam tells us it should all be straightforward.

## More Prizes

The second prize, a **Mannesmann Tally MT 80 Spirit printer**, has also been donated by Anderson Digital Equipment and is worth around \$800. It prints at 80 characters per second and provides such features as underlining, bold face, super and subscripts, italics and a special graphics mode.

Third prize, donated by Magmedia, is **three boxes of Xidex precision flexible disks**, either in 20 cm or 13 cm format, as the winner wishes. These diskettes retail at between \$60 and \$70 per box.

Fourth and fifth prizes are two years' and one year's subscription to *Your Computer* respectively.

Aside from winning one of these marvellous prizes, the winner's name will be publicised nationally, and he or she will retain ownership of the winning program to market, publish or otherwise use as they please.

The winning program does not necessarily have to be super-complex or business-oriented. The spirit of the competition is to reward original Australian initiative in producing a well-written, well-structured, useful and innovative program. It should reflect an original approach to solving a problem (regardless of its size or complexity) by the use of a computer.

## ENTRY FORM

## GREAT AUSSIE SOFTWARE COMPETITION

Please complete this entry form and send it, with your program and resume, to **Great Aussie Software Competition, 'Your Computer', 140 Joynton Avenue, Waterloo 2017.**

In the event of a joint entry, please list separately the names (and, if applicable, job titles) of the competitors.

Name 1 (and job title): .....

Name 2 (and job title): .....

Name 3 (and job title): .....

Address: .....

.....Postcode: .....

Language of Entry: .....

I declare that the attached program is original and has been written by me/my group\*.

\*Delete as necessary.

Signature: .....



*Believe it or not, dBase II is not the only database program this magazine has ever heard of; we've reviewed several others and are always on the lookout for new ones. So we thought it was time to bring the whole question of databases together in one big article and see if there really is a 'perfect' product on the market.*

# THE GREAT DATABASE SEARCH

**By Matt Whelan**

*(Your Computer's erstwhile Managing Editor, now up to his neck in accounting programs, utilities, system crashes and the general malaise of system managers.)*

I LOVE dBase II. It is a brilliant piece of software: simple enough to allow the near-beginner to do useful work almost instantly, and complex and powerful enough to handle his most difficult applications once he develops into an 'old hand'.

It is *the* database as far as the market is concerned, with more than 200,000 copies (probably half a million if you count the pirated ones) in users' hands. Third-party support for dBase II is excellent, with program generators, utilities and books devoted to it available at every corner computer store.

I have used dBase almost daily since we first reviewed it in *YC* in 1982. I've written countless utilities, mailing list managers, subscription systems and even an invoicing/debtors ledger program using it. The Mi-Computer Club's bulletin board message subsystem is written entirely in dBase II's programming language – and so too, now, is the bulletin board entry and message system on the SPA-RCPM in Sydney.

I also hate dBase II, and I'm looking for an alternative. It is the very power of dBase which brings you face to face with its deficiencies. The more you use it, the more you realise just how much it is capable of – until the day you find yourself saying "I could knock that one over easily in dBase, *if only* ..."

Now I seem to be saying 'if only' too often for my liking, and from calls and letters I've received I'm obviously not the only one who wants a better database.

The software industry agrees. Whether it's because it, too, feels I would be happier with something better or because it wants to share in Ashton-Tate's pot of gold is uncertain, but the result has been a rash of

new database packages that promise supposedly unprecedented power and ease of use.

The 'non-technical database' was one of the bigger themes at Comdex/Fall in Las Vegas last November: packages which took English-like commands, interpreted them, and returned the answers to all your questions were in abundance. There was even evidence of artificial intelligence-like software which could be taught that "gimme the turkeys" really meant "list all salesmen who haven't achieved target for the last three months" (our very own Richard Pakalnis and David McDowall have insisted this package never be reviewed in *YC*).

With all that effort going into database development, I figure there have to be at least a few – and probably many – products which make dBase II look like kindergarten fare. There are plenty which claim to do that, but if we were to believe them all we would have to decide that dBase was the worst package ever written.

Nevertheless, it is time some of the claims were investigated. Is there really a new database out there sufficiently advanced to justify the pain and cost (in time, if nothing else) of converting? Is there a package which does it as easily as dBase, has the same flexibility and power, yet overcomes all the limitations?

## **The Great Database Search**

It's time to find out. It's time for the great database search.

I plan to spend as much time as possible over the next six months (or year, if necessary) studying the promising new databases, as I have been doing since Comdex anyway.

I'll report on them all, one way or another, but only after a solid workout in the real world of large files, multiple indexes and actual applications. Typically, I'll duplicate one of our in-office systems (mostly handled by dBase) with the new product and report on how easy/hard the programming was as well as how good the performance of the new system is.

The new version will also be handed over to the users to see just how well it works in the day-to-day office situation. Developing an application is only part of the work, especially with databases – once they're in use the real job starts, adjusting the program to suit constantly changing user requirements.

With a little help from my friends like Les Bell (thanks, Les, I know you'll volunteer; won't you?), and Ray Price from the University of New England at Armidale (he's well down the road of studying new packages – a quick talk with Ray has already saved me from wasting time with some of the 'pretenders to the throne'), I'll try to look at everything which claims to be a dBase beater.

The reports won't necessarily come thick and fast, because such in-depth evaluations take time. For example, we've had DataFlex – one of the more promising packages I've seen – under test for some months and we're not finished yet.

## **What's Wrong with dBase?**

Before we examine the alternatives, we should start out with a look at the yardstick by which they must be judged: dBase II itself. It is the standard, determined by popular choice where it counts – in the marketplace.

The first, and major, disappointment ►

# THE AFFORDABLE HIGH PERFORMANCE PLOTTERS - FROM ROLAND.

If you've travelled overseas, then you would have heard about Roland Corporation's high-performance, low-cost, multi-pen, color plotters. Now, you won't have to travel because they are available here from Roland dealers in all States.

Roland's high performance 8 pen plotter also comes with a single pen variant (DXY101). These flatbed X-Y plotters are the most compact units of their kind and come in a portable carry case.

They have an effective plotting range of 360mm x 260mm (A3) and can operate on an incline up to 60° a practical application in the work situation.

Maximum operating speed is 180mm/sec, very fast for this type of plotter. Optional speed settings allow adjustment for different types of pen and paper. Additional pen holders are supplied allowing use of a wide variety of pens with the DXY800.

Roland X-Y plotters feature a wide variety of command applications; vector commands,



character commands, graphic commands and pen exchange commands.

Both RS-232C Serial and Centronics parallel interfaces come built-in as standard features, making Roland X-Y plotters compatible with virtually every model on the market. And we have support graphics software.

But the most pleasing aspect about Roland plotters is their price. Give us a call ... you'll be amazed.

**JUST RELEASED**  
BPS Business Graphics & drivers  
for virtually all leading Graphics  
software. Lotus 123 Drivers  
available soon.

# Roland



**Roland Corporation Australia Pty. Ltd.,**

39 Victoria Street, Fitzroy, 3065.  
Telephone: (03) 417 1800.

23 Cross Street, Brookvale, 2100.  
Telephone: (02) 938 3911.

# THE GREAT DATABASE SEARCH



is the eventual lament of all dBase II programmers: "if only I could have more than two files open at once". Without that limitation there would be little to stop dBase becoming the most important piece of software in many offices.

It has other drawbacks, of course. A limit on the number of memory variables allowed (64) is a real pain, but that wouldn't be a problem if more files were available: many variables used in dBase II programs are system counters/totals or constants such as drive identifiers and are better kept in a file anyway.

There are a number of limitations, some documented in the manual (and quoted gleefully by the opposition in the many 'look at us compared to dBase' charts that appear in advertising around the world) and others discovered by painful experience.

Of the documented limitations, I consider three significant: the number of database files you can have open, the number of memory variables available, and the limit of 32 fields per record.

I have never needed a database with more than 65535 records, even if the opposition considers this a limitation. For example, a name/address file with that many records would occupy about eight megabytes of disk space. Similarly, I have never needed anywhere near 1000 characters per record, although this limit may be significant in some applications.

The major 'undocumented' limitation of dBase is its speed. In simple, single-file operations it is quite quick for an interpreted language, but it can slow down dramatically if you start switching between files (often a must with the two-file limit) or if you use multiple indexes. The more complicated a program gets, the slower the application gets, because dBase is heavily disk-bound in comparison with other languages.

Command files must stay relatively small, and you cannot have subroutines in the same file as your main program, so dBase has to load multiple command files from disk, usually many times in the course of a work session.

Generally, it doesn't matter how

fast your processor is – the program spends most of its time reading from (and writing to) disk anyway. However, if you put dBase to work in a multi-user system you quickly find out just how incredibly greedy it is with all system resources.

## The Painful Experiences

In the 'painful experience' class, there are enough bugs (especially in versions earlier than 2.4, and particularly in the 16-bit versions) for us to suggest Ashton-Tate hasn't given the product the support its success justifies. If the opposition can produce completely new programs in response to dBase, why can't Ashton-Tate tidy up its own product in the same amount of time?

More significantly, most of the bugs are public knowledge to those with the right contacts, and have been documented by Ashton-Tate, yet the poor old end user hasn't been told about them.

One in particular I consider disastrous, because it can affect the whole system rather than just the particular dBase application. (Note: If you're superstitious, don't read the next three paragraphs or the 'telepathic bug' may get you. I had used the offending dBase statement happily for six months, yet it 'got' me the day after Les Bell told me about it!)

The FILE statement is the one which can cause disaster. If your program says FILE('filename'), dBase returns a logical result telling you whether 'filename' exists in the directory. It's a particularly useful function, one used often for error-trapping, and I hate having to live without it. But I will *never* use it again.

According to Ashton-Tate (if you happen to get hold of the bug notification), using this function while a database file is open may erase other files from the directory. The day it got me, it didn't just erase files – it rewrote a 32-file block on the hard disk's directory by shifting the whole thing one byte to the right. Moving the file allocation pointers made all the space free as far as the operating system was concerned, so all the files' contents were overwritten on the disk. If it had simply 'erased' the directory entries, I could have recovered around 25 of the files, but in this case I lost them all!

Ashton-Tate says you can avoid the problem by closing any open files with the USE or CLEAR command before using FILE, but I know of one user who does so religiously and has still been hit. I can live with a bug

that stops my application working the way I want it to, but one that munches on my disk directory really makes me mad ...

## What's Right With dBase?

dBase II has an awful lot going for it, make no mistake. Its capabilities are seemingly endless – every time I reread the manual I discover something I hadn't noticed before, and every time I read a book or an article on using dBase I learn something new.

If you compare it to traditional compiled languages, dBase II code may be inefficient and slow; however, it is far more useful than those languages in that simple applications can be brought up virtually instantly and complex applications almost as quickly.

While a project is in the developmental stages changes to file design and such are so easy that it encourages you to improve on your original design whenever the need arises.

It is a perfect way to get an application up, and fine-tune it to the users' needs, in minimal time. The interactive immediate-mode command-line interpreter (something many of the 'more powerful' database packages don't have) allows you to test commands immediately, and also lets you extract information from your databases without any programming at all.

Once the application has settled down and is running just the way you (and the users) want it, then – if it is getting heavy usage, is running frequently or starts to consume too much machine time – you can think about rewriting it in a more efficient language. You have a nicely structured, readable piece of 'pseudo-code' on which to base your rewrite, you know your file design/layout is right, and you have a working version to keep the users happy while you develop the replacement.

An immeasurable advantage is the product's marketplace acceptance. There are enough books on dBase to turn the complete novice into a competent applications developer. There are enough support tools available to halve the amount of work you have to do. And there are enough people using it to enable you to easily find someone to ask advice.

The large user base is worth a lot more than many people realise. For example, I have dBase programs which will read my system clock to set the date (and tell me the time), to perform operating system calls to change printers, drives, user numbers and a lot more, and to allow me to

issue an operating system command from within dBase (like using PIP to copy files, or firing up WordStar from within dBase to edit programs). All these programs, which use dBase's machine language call capability (another rare feature) were provided free, required no work on my part, and are invaluable.

The third-party software tools, like dBPlus, dUtil, Quickcode, Autocode, dBDoc and so on are the sort of excellent aids that users of most other programs just can't get.

In fact, every time I think about changing from dBase I wonder whether I'll ever be able to live without it. Perhaps I really should be patient — the word is there's a multi-user version due for release any day now (multi-user capability is high on my list of priorities) and a complete rewrite which *will* allow you to use more than two files at once is likely to hit the stores later this year.

Later this year may be too long to wait, however, especially if the new version comes complete with bugs. No, I think the new dBase will have to get in the queue for evaluation just like the other database packages in our search.

### The Opposition

The following is an incomplete summary of dBase's competition — incomplete because the packages on the list are only those which have

happened to come to my attention in recent months. Obviously, as the search continues the list will expand.

I'll leave out the 'list managers' like pfs:File, Perfect Filer, LisaList and so on; I won't touch on packages we know can't match dBase as it stands, nor will I look at special-purpose programs such as Caxton's Cardbox.

It seems that once you eliminate the also-rans, the 'differents', the specialists and the not-available-here-yet packages we keep hearing about, there's not a lot left. However, what is there represents a fair amount of power.

Among the not-available-yet programs, there are a few interesting ones: **R:Base** and **Salvo** were two of the better-presented newcomers at Comdex, but there were several others proclaiming ease of use, English-like commands, and superiority over dBase.

Both packages looked impressive in demonstrations (though neither was as impressive as the extensive R:Base advertising campaign — *D Old Way v R Way, D Old Number of Files v R Number of Files*, and so on over six pages of major magazines). Less impressive was the sample copy of Salvo sent to me after the show, although to be fair it was clearly specified that I was looking at a pre-release version. The concept of the Salvo system looked good, so as long as they get the software to live

up to its documentation it will be worth watching out for.

I haven't looked at R:Base at all, even though I brought a demo disk back from Comdex. Like just about everything else at the show, it was in IBM-PC format; I don't have an IBM to test it on, and I'm trying real hard not to get one. Les Bell is giving it a run-through, so we may hear more about it later.

Perhaps the two most promising dBase challengers are **Knowledgeman** and **DataFlex**, both of which I've looked at reasonably closely recently.

Knowledgeman (short for Knowledge Manager) was reviewed in the September 1983 issue, where Les Bell said it was "considerably more advanced than dBase". He was right (yes, Les, I know I didn't need to say it) — it is a stunning package, with more conventional database power than dBase plus an excellent spreadsheet thrown in for good measure.

The fact that it can read its database files into the spreadsheet for advanced calculations, and write spreadsheets out to database files, is a real plus. It can have 'unlimited' files open, 'unlimited' working variables, and 255 fields (or 65535 characters) per record. Unlimited, by the way, means 'limited only by your hardware'.

It looks brilliant on paper, but there are two problems. The first is a simple one — I've only had a demo

A sample dBase program which illustrates the benefits of a wide user base — utilities like this are widely available from other users.

```

*** A dBase II program which performs operating system function
*** calls. calling program stores the function name it wants
*** to memory before DOing this program.

DO CASE
  CASE !(funct) = "CONDATLST"
    *** conditional attach of printer in multi-user system
    STORE 161 TO function
    STORE 255 TO arg
  CASE !(funct) = "SETUSR"
    *** set new user number
    *** calling prog must set arg to user number wanted
    STORE 32 TO function
  CASE !(funct) = "GETUSR"
    *** get current user number
    STORE 32 TO function
    STORE 255 TO arg
  CASE !(funct) = "SETLST"
    *** set list device required
    *** calling function must set arg to printer number
    STORE 160 TO function
  CASE !(funct) = "GETLST"
    *** determine current printer number
    STORE 164 TO function
    STORE 255 TO arg
  CASE !(funct) = "ATLST"
    *** non-conditional attach of printer
    STORE 158 TO function
    STORE 255 TO arg
  CASE !(funct) = "DETLST"
    *** detach printer
    STORE 159 TO function
    STORE 255 TO arg
  CASE !(funct) = "ATTCON"
    STORE 146 TO function
    STORE 255 TO arg
  CASE !(funct) = "DETCON"
    *** detach process from console
    STORE 147 TO function
    STORE 255 TO arg
  CASE !(funct) = "GETCON"
    *** determine user's console number
    STORE 153 TO function
    STORE 255 TO arg
  CASE !(funct) = "SETCON"
    STORE 148 TO function
    *** calling function must set arg to console number
  OTHERWISE
    ? chr(7)+ "Function call error..."
ENDCASE
POKE 29,function
STORE int(arg/256) TO arg2
STORE arg-(256*arg2) TO arg1
POKE 30,arg1
POKE 31,arg2
POKE 32,58,29,0,79,42,30,0,235,205,5,0,34,48,0,201
SET call TO 32
CALL run
STORE peek(48) TO result
RELEASE run,arg1,arg2,funct,function,arg
RETURN

```

# THE GREAT DATABASE SEARCH



copy, limited to 50 records per file, to look at, so I won't be able to report on it in depth at this stage. The second is probably irrelevant to most people, but is an important consideration for me: there is no intention of releasing a multi-user version of KnowledgeMan.

This package is produced by Micro Data Base Systems, the people behind MDBS III – by all reports an exceptionally powerful minicomputer-standard network database system for micros. MDBS wants to sell you up to this package for more advanced applications, which might not be such a bad idea – except it is so expensive I haven't been able to obtain even a brochure on it in Australia ...

However, if I was looking for a database package for my single-user micro I'd find it hard to go past KnowledgeMan, even if only on a value-for-money basis. Hopefully I'll be able to look at it in more depth and report later, but in the meantime make sure you at least look it over if you're looking for a database manager.

KnowledgeMan is distributed in Australia by Multisoft, of Perth, and also by HiSoft, of Melbourne.

## At Last! A Multi-User Database

It's not the only one, but it's the only one I've seen that works. DataFlex, distributed here by Intelligence Australia, of Sydney, is a particularly impressive package that has been around for a while but has only recently started to gain recognition.

One of the strongest recommendations I have for it is its availability over a wide range of operating systems – there are versions for CP/M-80, CP/M-86, MP/M-86, MS-DOS, PC-DOS, TurboDOS, Novell ShareNet, PC-Net, Televideo MMMost, and more; with support like that you can hardly get into trouble.

I am far from finished with DataFlex, but I've already given it enough of a workout to be impressed. There are a few things I don't like about it, but I'll save them for the full review – the people at Intelligence tell me a new version (which I should have by the time you read this) answers most, if not all, of my complaints.

I first 'met' DataFlex more than a

year ago, when a copy arrived at the office addressed to Bill Bolton. He had been talking to the manufacturer, Data Access Corporation, at CP/M '83 and one day soon after a review copy turned up in the post.

I took it home and read the manual before seeing Bill the next day. I was just about to start writing an invoicing/debtors ledger system (now used by this publishing company) in dBase – a daunting task, by the way; I'm an enthusiastic end user, still far from being a programmer. I nearly cried when I read the description of *relationships* between files; this was a proper relational database system, and the 'automatic' features promised in the manual were going to be either impossible to achieve in dBase, or very complicated to write.

However, I passed the package on to Bill relatively happy in the knowledge that DataFlex was too much for me. You see, it was a 'programming by numbers' exercise: you had to follow up your form design with columns of numbers representing calls to various programming functions, and that's enough to frighten off even experienced programmers. As far as I was concerned, that was the end of DataFlex for me (though I did sit and wish for a while: *wish* dBase could do number 47, *wish* dBase could ...).

A few months ago, Roger Walker at Intelligence Australia phoned me to offer a review copy of DataFlex 2.0. Out of curiosity I said I'd be glad to look at it, especially when he told me it was a multi-user version. You can imagine my delight when I opened the manual and found the new version had 'Page:' written before every number!

Dataflex had a language. An impressive-looking, structured programming language which seemed to offer everything I had used in dBase with a few of the items from my 'wish-list' thrown in as well. All that, plus multiple (10) files open, 32,000 memory variables available (if the hardware can fit 'em) and proper relations between files – what more could I ask for? Well, you'll have to wait for the full review for the answer to that one (but one thing I do miss is the interactive command-line mode of dBase and KnowledgeMan) ...

Interestingly, the program-by-numbers approach still exists – part of the compiler process is to translate your command files back into the old number system (you'd never realise it unless you had used the previous version), which is a sensible way of avoiding a major rewrite of the run-time interpreter.

## Any More Contenders?

I wonder what happened to **FMS-80**? It had excellent specifications, and certainly looked to be a challenge for dBase, but it seems to have missed the bus here.

I remember looking at it at the same time as dBase (we reviewed it a month after dBase, in the June 1982 issue) and deciding it was both too hard (its most important feature, its UNIX-style shell-based programming language, was very poorly documented) and, because it was a big system run almost totally from menus, too slow on floppy disks.

There are others which make promises, but we haven't had a chance to see if the promises are genuine yet. Sunshine State Scientific Systems, in Queensland, is distributing an English package called Superfile which looks excellent from demos we've seen.

We currently have a copy for review, but as it's one of the early releases written specifically for the Z80 processor we can't just plonk it on any old machine to test (our 816 systems use 8085s as their 8-bit processors). Our review will take a little longer for that reason, but hopefully we can get Les to fire it up on his Kaypro – if he can clear a space among the other computers on his desk for long enough.

This package borrows its concept more from the mainframe/mini world, providing a system-resident shell of database management functions which can be called from 'standard' programming languages like Microsoft BASIC (it's also directly accessible from the command line).

It has some interesting features, like phonetic search – you can ask it to find a name that sounds like TOMSEN and it will show you any THOMSONs, THOMPSONs and so on from your file. More on that one later.

We've seen mention of a few other packages (Meta-4, an Australian-written program, and Data Base Manager II are just two of them), but you know as much about them as us for the moment. Hopefully the great database search will rectify that situation soon enough ...

**Software distributors note:** If you want your product included in the great database search, don't assume we've seen it (or even know about it). If you have what you consider a dBase II beater, let us know. If you're sending a review copy, note that we can run either CP/M-80 or CP/M-86/MP/M-86 versions on our current office systems – CompuPro dual-processor machines running MP/M-816 (Televideo terminals). ▶

# QUALITY & PERFORMANCE AT A PRICE YOU CAN'T RESIST!

## B M C BX-80 DOT MATRIX PRINTER

- Totally EPSON compatible at a much lower price
- Bidirectional 40, 80, 71, 142 column printing in normal, double width, or compressed modes mixable in line
- True descenders
- Superscript and subscript
- Superb graphics in character or bit image modes
- Integrated friction feed with built in sprocket tractor
- Takes any paper up to 10" width
- Italic printing
- Programmable line spacing
- Centronics interface
- Optional RS 232 serial interface with 2k buffer
- Carbon lined ribbon gives superior results to EPSON



MAY/JUNE  
SPECIAL  
ONLY  
\$379 TAX PAID  
\$322 TAX FREE

## BROTHER HR-15 DAISY WHEEL PRINTER

- Letter quality printing at an unprecedented price
- Totally compatible with most microcomputer word processing systems including WORDSTAR
- Daisy wheel in a unique easy to change protective cassette
- Proportional spacing
- Shadow print for highlighting headings, etc.
- Friction feed
- Optional low cost tractor feed and cut sheet feeder
- Optional keyboard to convert to complete electronic typewriter
- Centronics interface standard, optional RS 232 serial version available
- Highest quality engineering from one of the world's leading typewriter companies
- Lowest price ever offered for this class of product

MAY/JUNE  
SPECIAL  
ONLY  
\$795 TAX PAID  
\$681 TAX FREE



**AED COMPUTERS PTY LTD**

P.O. BOX 1195 PARRAMATTA 2150 (02) 689-1744 TELEX AA 70664

# THE GREAT DATABASE SEARCH



## DATAFLEX

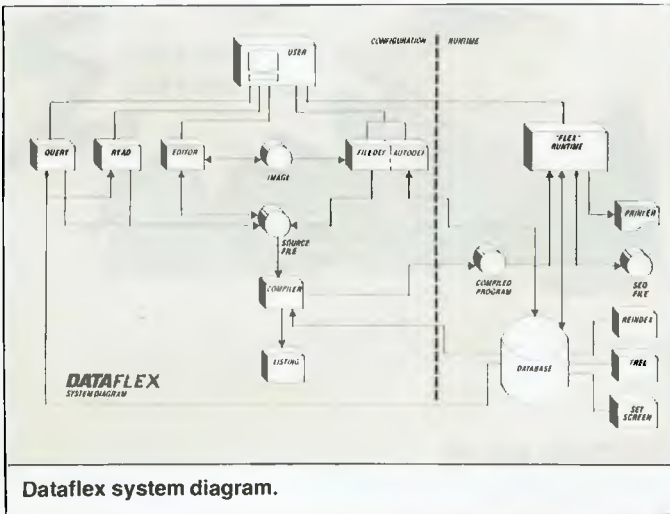

Dataflex system diagram.

```

/HEADER
                                VENDOR FILE

VENDOR                          TERMS CREDIT LIMIT CREDIT USED PURCHASES LAST PURCH
/ENTRY RESIDENT
_____

/*
//This report is as simple as they come. It uses only one
//variable for its output. Except for these comments this report could
//have been produced by the QUERY program.

OUTFILE                          //direct the output to the
OPEN VENDOR INDEX.1              //printer (default)
                                //open the vendor file buffering
                                //index by vendor name

REPORT VENDOR BY INDEX.1        //print each vendor in the
SECTION HEADER                   //database in vendor name order
OUTPUT HEADER                    //print the page header information

SECTION BODY
PRINT VENDOR.RECNUM              //system assigned number
PRINT VENDOR.VENDOR
PRINT VENDOR.TERMS
PRINT VENDOR.CREDIT_LIMIT
PRINT VENDOR.CREDIT_USED
PRINT VENDOR.PURCHASES
PRINT VENDOR.LAST_PURCHASE
OUTPUT BODY                       //print the page
REPORTEND
ABORT
    
```

A simple Dataflex report program.

```

/Form
DATA ACCESS CORPORATION          CUSTOMER MASTER FILE

CUSTOMER NUMBER: < .>

NAME: < _____>

ADDRESS: _____

CITY: _____ ST: _____ ZIP: _____

DISCOUNT: .3

PURCHASES/MONTH $ _____ PURCHASES/YEAR $ _____

PROFIT/YEAR $ _____

Windows with < > can be used to FIND customers
/HELP1 HELP

=====
CUSTOMER ENTRY HELP SCREEN

This screen will enable the user to input and maintain the customer file in
the Dataflex demonstration application. This is a standard "ENTER" screen
and as such uses the standard "flex keys". Operations that can be performed
are: Customer record creation, deletion, editing and inspection.

The customer file is indexed on the Customer Name field and Customer Number.
On the screen the index key can be accessed by placing the cursor over the
customer window and pressing the "FIND" key.

For more help on individual fields press the help key again, otherwise press
any other key to return to the customer screen.
/HELP2 HELP

=====
CUSTOMER HELP SCREEN TWO

CUSTOMER NUMBER: If you know the customer's number, enter it here. To create
new customers, press RETURN and let the system assign the customer
number for you.

CUSTOMER NAME: If you entered a valid number the cursor will skip this field,
Otherwise you may use the flex keys to find a valid customer by name.

ADDRESS,CITY,STATE,ZIP : The address of the customer to be shown on the bill
to window on the invoice.
    
```

```

DISCOUNT : Any customer discount applicable to purchases should be entered
here. The discount will automatically be taken into account when
computing invoice totals.

PURCHASES/MONTH, PURCHASES/YEAR, PROFIT/YEAR : These will be maintained auto-
matically by the INVOICE screen.

The user defined key will print the screen
/*
// This is a simple ENTER configuration for vendor file maintenance.
// Since the window's are processed sequentially, the AUTOPAGE function can
// be used and the windows do not have to be explicitly named.

OPEN CUSTOMER                    // All files must be opened
ENTER CUSTOMER
AUTOPAGE FORM

// Each ENTRY command is followed by the database element it references.
// The window is assigned by autopage. After the command the
// options surrounded by [].

ENTRY CUSTOMER.RECNUM            [AUTOFIND,NOPUT]
// Translation, do data entry on the record number of the customer
// file. Automatically FIND by this field when data in input, but
// do not put data back into the record buffer since record number
// can't be changed.

ENTRY CUSTOMER.CUSTOMER
// Translation, do data entry on the customer name of the customer file

ENTRY CUSTOMER.ADDRESS
ENTRY CUSTOMER.CITY
ENTRY CUSTOMER.STATE
ENTRY CUSTOMER.ZIP
ENTRY CUSTOMER.DISCOUNT
ENTRY CUSTOMER.PUR MONTH        [DISPLAYONLY]
// Translation, when the customer file is found; display purchases
// for the month in this window

ENTRY CUSTOMER.PUR YEAR        [DISPLAYONLY]
ENTRY CUSTOMER.PROFIT          [DISPLAYONLY]
RETURN                          // return from entry action
ENTEREND                        // end of enter configuration
ABORT                            // abort after escape key.

KEYFLEX KEY.USER                // Define action of user defined key
OUTPUT FORM                     // Output our only page
ENTAGAIN                         // Return to same window
RETURN
    
```

A simple Dataflex entry program. It has a data entry screen, help screens, and data entry definitions using the Enter macro.



When you can't  
afford mistakes.

There really is a difference  
in diskette brands.

It's in the way they are  
made.

Because the computer  
industry cannot afford  
variation in the quality of  
diskettes, at Nashua we  
looked for, and found a  
way to ensure absolute  
consistency.

Here's how we do it.

Quality Circles.

At Nashua we've found  
the best way to attain this  
'consistency' is to ensure  
that at each stage of  
production our diskettes



are statistically checked to  
make sure the quality is  
'built-in' every step of the  
way.

Rather than long  
production lines, we have  
'Quality Circles' – small  
groups of people whose job  
it is to make sure that each  
Nashua diskette is right in  
the first place.

The result is a diskette  
with such consistency, that  
it is chosen by those people  
who can't afford mistakes.

Phone Sydney 958 2044,  
Melbourne 428 0501,  
Brisbane 369 4244,  
Adelaide 42 0021, Perth  
328 1888, Hobart 34 3761,  
Darwin 81 6204.



There really is a difference.

# MICROMAIL

Australia's No. 1 Microcomputer Mail Order Club.

FREE MEMBERSHIP WORTH \$30 WITH  
PURCHASE OF \$100 OR MORE ON INITIAL ORDER.  
SPECIAL OFFER OF THE MONTH PART I

(see below for membership benefits).

For Commodore 64  
**Sublogic Flight Simulator**  
now available for **\$64.95**

**Superbase 64** For Commodore 64  
the powerful RRP  
database \$180  
Micromail \$149

## Commodore

	RRP	Micromail
Prices include sales tax.		
COMMODORE 64	499.00	399.00
1541 Disk Drive	499	399
Datasette	49.95	42.95
802 printer	499	439
1701 Colour Monitor	499	449
SX-64 portable	1499	1375
Koala Pad	149.95	134.95
Stack Light Pen	79.95	75.95
Games for Stack Light Pen	24.95	21.95
Parallel interfaces		call
Multiplan	149.00	129.00
The Manager	100.00	85.95
Simons Basic	80.00	74.95
Magic Desk	60.00	49.95
Intro to Basic 1/2	40.00	32.95
Easy Script	100.00	85.95
Bank Street writer	83.95	75.95
Home accountant	105.00	89.95
Avenger	29.95	25.95
Super Lander	29.95	25.95
Zork I II III	25.95	21.95
Homeword	59.95	52.95
Choplifter	54.95	46.95
LOGO	100.00	85.95
Typing Tutor	21.95	17.95
Colosus chess	35.95	29.95
Data Manager	29.95	25.95
Programmer's Reference Guide	28.00	22.00
Wanda-Adults Only	29.95	25.95
Hover Bover	29.95	19.95
Academy IFR Flight Simulator		64.95

Computer Tutor	79.95	69.95
BC Basic		80.00
Jumpman	54.95	46.95
Video Pak 80	289.95	259.95
Light Rifle	99.95	95.95
IEEE	129.00	124.95
4 slot cart. exp.	89.95	85.95
Arrow (cass. speed up)	89.95	85.95
Compiler	69.95	65.95
Quick Brown Fox		99.95
Quicksilver software	call	call
Electronic Arts software	call	call

And More

## ATARI

	RRP	Micromail
Prices include sales tax.		
600XL	399.00	349.00
800XL	599.00	549.00
1050 Disk Drive	699.00	629.00
1010 Program Recorder	159.00	149.00
Koala Pad	149.00	139.00
Choplifter	48.95	42.95
Atari Writer	119.95	105.95
Donkey Kong	79.95	69.95
Parallel Printer Interface		139

FOR ALL PRODUCTS NOT LISTED CALL (02) 467-1933

Visit our showroom at No. 1,  
303 Pacific Hwy., Lindfield NSW 2070 Training available.

Despatch guaranteed in five working days. Shipping and handling charges:  
Hardware — Sydney \$5.00, anywhere in Australia \$10.00

Courier Delivery Prices subject to change without notice.

## Apple

	RRP	Micromail
Hardware (excluding sales tax)		
CED card parser	135	99.00
Microbutler 16K	256.00	220.00
Super 5 TEAC Drive	495	347
Digitek Printmaster	202	130
Chinon Disk Drive	475	325
Software (includes sales tax)		
Homeword	59.95	52.95
Bank Street writer	\$98.95	\$86.95
Zurdax	324.00	258.00
PFS File, Graph, Report	175.00	149.00
D Base II	825.00	689.00
Home Accountant	105.00	86.95
Ultima III		89.95
Master Type	64.95	54.95
Graphics Magician	84.95	79.95
Wizardry	81.95	69.95
Choplifter	48.95	39.95
Loderunner	40.95	41.95
Flight Simulator	56.95	46.95
Sargon III	avail	74.95
Zork I II III	60.95	50.95
Other software	call	call

Manufacturer's full warranty on all products.

## Sinclair

ZX Spectrum 16k	299.00	269.00
48k	399.00	349.00
Microdrive	149.00	135.00
ZX1 Interface	149.00	135.00

## Sanyo 16 bit

	RRP	Micromail
Prices include sales tax		
MBC 550 PC + 160k drive	1495.00	1395.00
MBC 550/2PC + 320k driv	1995.00	1850.00
MBC 555 + Dual 160k driv	1995.00	1850.00
MBC 555 + Dual 320k driv	2595.00	2449.00
Micropro Wordstar + Calcstar	195.00	180.00
Micropro Mailmerge + Spellstar + Infostar	295.00	275.00

More hardware and software call

## FLOPPY DISKS

Le Floppie (10) SSDD	49.95	37.95
2 Pack Le Floppie	10.00	8.95
Le Floppie (10) DSDD	80.00	59.95

Order by phone  
Sydney 467-1933  
Australia Wide (008) 23-0200  
(Toll Free)  
24 Hour Service  
Bankcard and Mastercard Welcome.

OPEN SATURDAY

## IBM

	RRP	Micromail
Software includes sales tax.		
Friday	360.00	320.00
Lotus 1 2 3	895	599
Visicorp specials	call	call
Padmede Acctg. modules	390.00	325.00
Wordstar 3.24	595.00	200.00
Spellbinder	795.00	595.00
Sybiz software	call	call
Supercal: 3	445.00	369.00
D BASE II	825.00	689.00
Multimate	595.00	495.00
Temple of Apshei	65.95	56.95
Flight Simulator	87.95	74.95
ZORK I, II, III	59.95	49.95
KOALA PAD	199.00	179.00
Sargon II chess	54.95	48.95
More software	call	call

## HARDWARE (Excludes sales tax)

Quadboard	call	call
Davong 64K Ramcard	359.00	299.00
Quadlink	875.00	699.00
Davong 5MB Drive (EXT)	2880.00	2399.00
Persyst boards	call	call
Microfazer 64k serial	445.00	395.00
AST boards	call	call

and more!

## MONITORS (includes sales tax)

	RRP	Micromail
Kaga Green	269.00	249.00
Teco Green Screen	\$249.00	\$199.00
Teco Amber Monitor	275.00	220.00
Sanyo anti-glare green	299.00	279.00
Kaga green/IBM PC Mon	327.00	309.00
Kaga Amber/IBM PC Mon	340.00	319.00
RGB + Composite Video Colour	463.00	435.00
RGB Colour 640x262	775.00	725.00
JOYSTICKS		
NEW 3 Fire button Joystick	\$22.95	17.95
Superchamp	29.95	27.95
Triga Command	19.95	18.50
Kraft	88.95	79.95
Wico 3-way joystick	49.95	45.95
Superjoy	24.95	17.95

## PRINTERS includes sales tax

Amust DT80	449.00	379.00
Super 5 CP 80	499	360
Star Gemini 10x	599.00	475.00
Star Gemini 15x	955.00	795.00
Uchida daisywheel 20cps	799.00	649.00
SP2000 Daisywheel	995.00	750.00
Juki 6100 Daisy Wheel	995.00	850.00
C-Itah 8510 par	1340.00	995.00
C-Itah 1550 par	1635.00	1250.00
NEC printers	call	call
Modems		
Cicada 300	250.00	210.00
Cicada 300T	275.00	240.00
Cicada 300 for Commodore 64	275.00	225.00
Cicada 300T for Commodore 64	295.00	249.00
CPM software	call	call
Microsoft software	call	call
Typequick	\$80.00	\$60.00

Members receive: Discount vouchers for future purchases.

Microgram quarterly publication.

Or send cheque or money order to Micromail, No. 1, 303 Pacific Hwy., Lindfield NSW 2070

# MICROMAIL

Australia's No. 1 Microcomputer Mail Order Club.

New Showroom Opening Specials

No. 1, 303 Pacific Highway, Lindfield NSW 2070

New Phone Number: 467-1933. Order Line outside Sydney: 008-230-200

For the Commodore 64

Introducing **BCBASIC**

A Micromail Exclusive

Adds 104 Commands and Functions to the Commodore 64. **ONLY \$80 (cart)**

CATEGORY OF FUNCTIONS	BC BASIC			SIMONS' BASIC		
	Ease	Use	Reliability	Ease	Use	Reliability
Graphics set up	****	****	*****	***	**	****
Plotting commands	****	***	*****	****	****	****
Misc screen commands	****	***	*****	****	***	****
Sprite set up	****	****	*****	****	****	****
Sprite programming	****	****	*****	****	**	****
Keyboard input	****	**	*****	***	****	***
Misc input/output functions	*****	*****	*****	**	*	*****
Sound set up	*****	*****	*****	****	****	*****
Sound programming	***	****	*****	**	***	***
String commands	****	****	*****	***	****	*
Arithmetic commands	****	****	*****	**	***	**
Structured programming	****	*****	*****	****	*****	*****
Programmer aids	none	none	none	****	**	***
Total points	49	47	59	43	42	47

"BC Basic is very robust and bug free. It's commands are well thought out and much more versatile and useful in practice than Simon's Basic"  
— Commodore User Mag.

## MEMOTECH



Micromail Exclusive

Memotech MTX 500 32k User Ram

Memotech MTX 512 64k User Ram

Expandable to 512k Ram

Z80A processor 4 MHZ Built in

software — MTX Basic, MTX Logo,

Noddy, Assembler, Disassembler.

Optional CPM Floppy Disk System

5 1/4" Qume Drives — 500k capacity

each Silicon Disc (1/4MB) increases the

efficiency of 8 bit software

to those of 16/32 bit software.

Hard Disk — 5 1/4" Winchester

5, 10, 20MB

MTX 500 Computer Only \$699

MTX 512 Computer Only \$799

New Word w/p cart Only \$219

FDX Floppy Disk System call

Software from 19.95 call

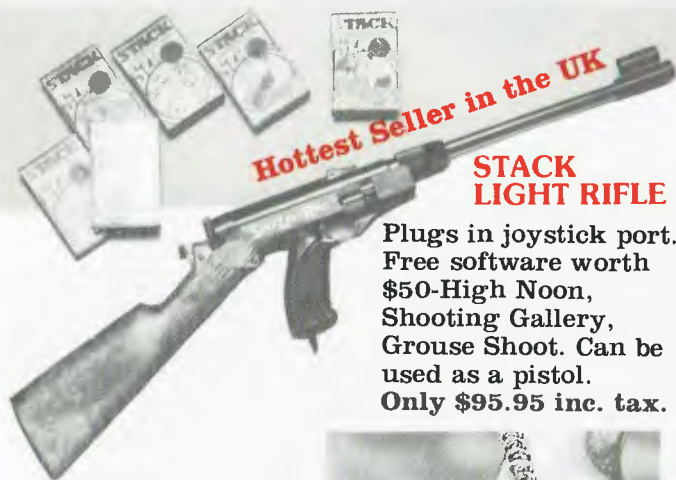

Hottest Seller in the UK

**STACK LIGHT RIFLE**

Plugs in joystick port. Free software worth \$50—High Noon, Shooting Gallery, Grouse Shoot. Can be used as a pistol. Only \$95.95 inc. tax.

**Stack Light Pen**  
The best lightpen ever made for the C64. One year warranty. 10 software cassettes available. Only \$79.95 inc. tax.



**VIDEO PAK 80:**

80 column display.

Includes word processing and spreadsheet software.

Acts as a terminal emulator. Hi-res 80 column display.

Only \$259.95.



The above products are distributed by Interfaceware Pty. Ltd.  
Amust DT 80 printer with parallel interface — \$549  
Star Gemini 10x w/parallel interface — \$569  
Uchida daisywheel w/parallel interface — \$749

# NEW FOR COMMODORE 64

## VIDEO PAK 80:

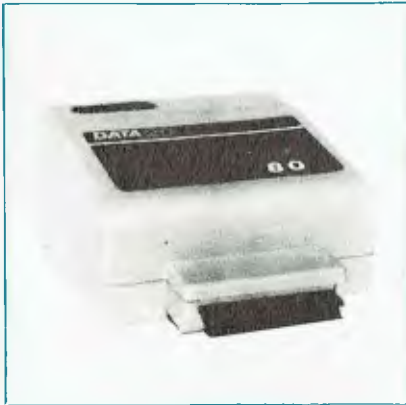

### Features:

- High resolution 80 column display
- Includes word processing software
- Includes spread sheet software
- Includes terminal emulator software
- 80 column mode allows full use of BASIC

The Video Pak 80, from Data 20, is an integrated system that features a word processor, spread sheet, and 80 column screen adapter cartridge for the Commodore 64.

## PARALLEL PRINTER INTERFACE:



### Features:

- Connects standard parallel printers to Commodore computers
- Translates the Commodore character set to ASCII
- Passes through graphics characters
- Does not require power hookup from the printer, computer or any external source
- Attractive packaging — it looks like a cable, no ugly boxes
- Easy to use — simply plug it in, no software to load or switches to configure

**DATA**  
CORPORATION

DEALER ENQUIRIES WELCOME

Distributed by

**interfaceware**

No. 1/303 Pacific Highway  
Lindfield, N.S.W. 2070  
(02) 46-4374

A new age has dawned  
with the  
**STACK  
LIGHTPEN**

It's a new, easier way to create software and it's fun too! The Stack Light Pen means freedom from the old labours of the keyboard and a new software style for the future.

Using the Light Pen means you can create programs for exciting games, with that extra dimension — sound — at the touch of the pen. With your Light Pen, you can remove words or images from the screen or put them back, cut out or simply move them about the screen. You can even trigger off a series of actions or actions, stopping them at will — with the touch of the Light Pen.

Always Available For **DOG ATARI WIZARD COMMODORE**

And it's so easy to use — simply hold it against the screen, touch the controls and away you go!

**LIGHTPEN SOFTWARE**

We've already created software for you to use with your Stack Light Pen...

**STACK LIGHT PENS and SOFTWARE are available from your LOCAL DEALER**

**STACK LIGHT RIFLE**

**Hottest Seller in the UK**

The SLR is available for the COMMODORE 64,

Included with your SLR are 3 exciting action games with full sound effects...**HIGH NOON, SHOOTING GALLERY and GROUSE SHOOT!**

More approved games titles are available from Stack and other software houses...**RATS & CATS, ESCAPE FROM ALCATRAZ, BIG GAME SAFARI, CROW SHOOT**

For those games that require agility and fast reactions, the SLR can break down from a rifle into a pistol.

The SLR connects to your computer by 12 feet of cable.

All this including 3 cassette-based games

**STACK**  
Distributed by

**interfaceware**

No. 1/303 Pacific Highway  
Lindfield, N.S.W. 2070  
(02) 46-4374

Please send me the latest information on Data 20 and STACK products

DEALER ENQUIRIES WELCOME

Name... Address...

Postcode... Ph...



*Now available at your  
computer store or bookshop . . .*

# SYBEX COMPUTER BOOKS



### APPLE II BASIC HANDBOOK

For the new Apple IIe and Apple II plus. Lists and explains, alphabetically, the entire Applesoft and Integer Basic vocabularies. All of the DOS commands are included along with many of the most important and commonly used computer terms. This book makes it easy to program your Apple computer for a multitude of home and office tasks. **\$26.95**

### ATARI BASIC PROGRAMS IN MINUTES

Versatile, ready-to-enter programs will enable you to perform over 65 home and business tasks with your Atari 800 or any of the new Atari XL series with 48K of memory. Use these handy programs for Home Finances — Business Calculations — Real Estate — Data Analysis — Record Keeping — Education. Many of them can be entered and ready to run in less than ten minutes. **\$23.50**



### BEST OF VIC-20 SOFTWARE

To help you choose and save time and money, this book presents the top VIC-20 software on the market today. The author tested over 80 VIC-20 programs and selected the best software for — Games, Music, Education, Home Management and more . . . **\$14.50**



### TIMEX/SINCLAIR 1000 BASIC HANDBOOK

Handy, computer-side reference will make programming your Timex/Sinclair 1000 easier, whether you're an experienced programmer or a first-time user. Lists and explains, each one of the 1000 BASIC keywords and function keys. With special tips and suggestions for using the BASIC vocabulary to make programming as simple and efficient as possible. **\$14.50**



### TIMEX/SINCLAIR 1000 BASIC PROGRAMS IN MINUTES

You don't have to be a programmer to program your Timex/Sinclair 1000, you simply need this book which will enable you to perform over 50 home and business tasks. **\$14.50**

### YOUR FIRST COMMODORE 64 PROGRAM

In one hour you'll be writing your first Commodore 64 program. A fun and easy introduction to programming computers with loads of colourful illustrations and simple diagrams. **\$22.50**



Available at bookstores and computer stores everywhere, but if you experience difficulty OR if you wish to receive regular information on new books, contact the distributor  
ANZ BOOK CO.  
10 Aquatic Drive, Frenchs Forest 2036  
(02) 452 4411).



```

RIGHT ACTION TO STMP (STRLEN-2)
// DISPLAY A QUESTION
MOVE ARGPOS TO ITEMP
INCREMENT ITEMP
MID ACTION TO QNUM 1 ITEMP
IF QNUM LE 6 GOTO NWMENU
IF QNUM GT 6 GOTO NWMENU
MOVE (QNUM-1*2) TO FIELDINDEX
MOVE MENU.QAL& TO QUESTIONA
MOVE MENU.QBL& TO QUESTIONB
// PROCESS RESPONSE
CLEARFORM RESPONSE
ACCEPT RESPONSE
LEFT ACTION TO ACTION (ARGPOS-1)
APPEND ACTION RESPONSE STMP
GOTO SUBST

DOLINE:
POS ' ' IN ACTION TO ARGPOS
INDICATE ARGS AS ARGPOS GT 0
[ARGS] RIGHT ACTION TO STMP (STRLEN-1)
[NOT ARGS] MOVE ' ' TO STMP
[ARGS] LEFT ACTION TO PRGNAME (ARGPOS-1)
[NOT ARGS] MOVE ACTION TO PRGNAME

DO2:
UPPERCASE PRGNAME
IF PRGNAME EQ 'MENU' BEGIN
MOVE STMP TO NEXT
GOTO NWMENU
END
IF PRGNAME EQ 'FLEX' CHAIN STMP
IF PRGNAME EQ 'CHAIN' CHAIN STMP
IF PRGNAME EQ 'SYSTEM' BEGIN
CLEARSCREEN
SYSTEM
END
IF PRGNAME EQ 'ERASEFILE' BEGIN
ERASEFILE STMP
GOTO NWMENU
END
IF PRGNAME EQ 'TYPE' BEGIN
IF STMP LT 'z' GOTO NWMENU
CLEARSCREEN
DIRECT INPUT STMP
REPEAT
  READLN STMP
  SHOWLN STMP
  KEYCHECK GOSUB WAITKEY
  LOOP
[NOT SEQEOF] CLOSE INPUT
[NOT SEQEOF] GOTO ENDKEY
END

IF PRGNAME EQ 'RENAMEFILE' BEGIN
GOSUB SPLIT
RENAMEFILE STMP TO XTEMP
GOTO NWMENU
END

IF PRGNAME EQ 'COPYFILE' BEGIN
GOSUB SPLIT
CLEARSCREEN
COPYFILE STMP TO XTEMP
GOTO ENDKEY
END

IF PRGNAME EQ 'DIRECTORY' BEGIN
CLEARSCREEN
DIRECTORY STMP
GOTO ENDKEY
END

// RUN PROGRAM FILE
CLEARSCREEN
RUNPROGRAM PRGNAME STMP
GOTO NWMENU // IN CASE OF NO FILE //

// WAIT FOR USER INPUT
ENDKEY:
SHOWLN
SHOW 'Please press return to continue:'
[INPUT STMP]
GOTO NWMENU

// PROCEDURE SPLIT - STMP INTO TWO NAMES
// STMP=LEFT, XTEMP=RIGHT
SPLIT:
IF STMP EQ ' ' GOTO NWMENU
POS ' ' IN STMP TO ARGPOS
IF ARGPOS EQ 0 GOTO NWMENU
RIGHT STMP TO STMP (STRLEN-1)
LEFT STMP TO STMP (ARGPOS-1)
IF XTEMP EQ ' ' RETURN NWMENU
RETURN

WAITKEY:
INKEY XTEMP
[KEY.ESCAPE] RETURN NWMENU
RETURN

KEYCHK KEY.ESCAPE
RETURN NWMENU
    
```

```

e.serr = true
e.lstr = 76
clear
putform types1
putform typesla
getform typesla
test upcase(menu1)
case "c":
  e.lstr=76;
  clear;
  putform types1;
  putform types2a;
  wait;
  e.serr=false
  return;break;
case "y":
  e.lstr=76;
  clear;
  putform types1;
  putform types3a;
  wait;
  clear types3a;
  putform types3b;
  wait;
  e.serr=false
  return;break;
case "M":
  release types1;
  release types1a;
  release types2a;
  release types3a;
  release types3b;
  perform "menus.lpf" using "\"z\"";
  return;break;
case "X":
  e.serr=false
  return;break;
otherwise:
  perform "conmenu.lpf";
endtest
return
    
```

```

form ad
@ 10,1 to 12,80 put "FR"
@ 10,1 put \
"This Demonstration is Written Entirely
@ 12,6 put \
"Knowledgegeman" with "R" In"
@ 12,31 put \
"Programming Language"
@ 21,19 to 21,56 put "FO"
@ 21,19 put \
"Please wait while data is being loaded"
@ 23,27 to 23,47 put "FC"
@ 23,27 put "Enter Date:" using "xxxxxx"
@ 23,39 get #date str using "dd/dd/dd"
endform
    
```

```

macro demo test diputs \
case "d": perform "defmenu.lpf";break;\
case "r": perform "datamenu.lpf";break;\
case "m": perform "modmenu.lpf";break;\
case "i": perform "indxmenu.lpf";break;\
case "c": perform "conmenu.lpf";break;\
case "e": perform "expmenu.lpf";break;\
case "f": perform "funcmenu.lpf";break;\
case "o": perform "formenu.lpf";break;\
case "s": perform "ssmenu.lpf";break;\
case "l": perform "langmenu.lpf";break;\
otherwise: perform "menus";\
endtest
    
```

```

e.serr=true
e.lstr=76
diputs = "z"
demon = "QU"
clear
putform ad
getform ad
load "menu.icf" /*load main menu form*/
perform "menus.lpf" using "\"z\"";
return
    
```

Two samples of Knowledgegeman's programming language. Note it knows about video attributes ("put Knowledgegeman with R" gives reverse video).

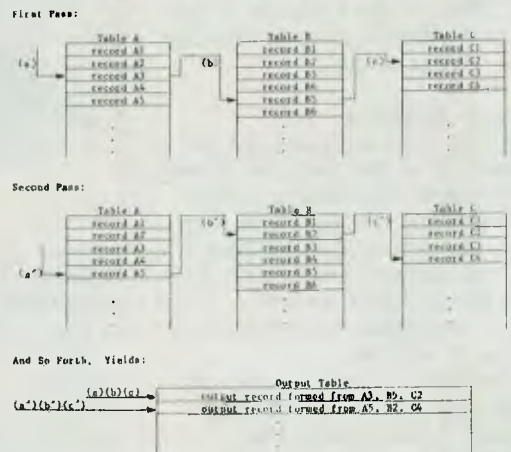

Example of the Knowledgegeman multi-table search protocol.

*The money in computing is in business solutions. Packages that combine good software with inexpensive, reliable computers are starting to sell like hot cakes. The big computer manufacturers have swooped on the business market, their traditional ground. But now the smaller companies are trying to break in, too. Evan McHugh investigated Microbee's offering.*

# A Microbee for Business

APPLIED TECHNOLOGY, manufacturer of Australia's own Microbee, is one small company that is trying to take on the business market from below. While the big companies go after major accounts in a 'from the top down' systems approach, Applied Tech is going after the small businesses working from the bottom up.

The company's latest release is the 128 Kbyte Microbee, a Z-80-based, bank-switched machine that comes with bags of software and tailor-made applications. The new Bee is not an earth shattering package, but if the number of calls *Your Computer* gets from people asking for something to help in their small business, for around \$1500, is any indication of the market possibilities, Applied Technology may just have a winner.

## The Basic Machine

The machine *Your Computer* got for review was not a standard job. It had a few little bells and whistles which cost around \$200 per bell. Also, our machine was a prototype, so there wasn't much documentation for it and some of the packages weren't running. Nevertheless, we pressed on and came up with this.

The computer is based on the old workhorse, the Z-80 microprocessor. In this case it is a Z-80A. The architecture of the machine makes one significant departure from normal. Applied Technology stuck with the Z-80 processor because of the significant



software base available with it. However, for a machine to be useful in business these days, it must have at least 128K of memory.

The 8-bit processor does not allow continuous addressing through all 128 kilobytes. Therefore, 128K of memory has been installed with the capability of switching from one bank of 64K RAM to another. In effect, what you get is an additional disk drive which is erased at every power down, but

which has the advantage of being very quick.

Obviously this facility has considerable advantages, but it didn't get used much on our machine. To be of real benefit there has to be a set-up routine which allows the user to specify the files he usually works with in a session, so they are immediately loaded into memory when the system boots.

As it stands, you don't use this ▷

# IF YOU CAN'T GET AN IBM PC, SETTLE FOR SOMETHING BETTER.

Once you discover the performance and the power of the Corona PC's,<sup>TM</sup> you'll quickly see the difference in today's standard for micro computing in the IBM-compatible world. Because the Corona PC's go beyond the standard to give you much more of what you're looking for in an IBM-compatible PC.



- Powerful, low-cost desktop and portable computers.
- 16-bit, fully compatible with IBM PC standard.
- Crisper, cleaner display and higher resolution graphics (640x325 pixels).
- 128K byte memory, room for 512K bytes on main board.
- Fast-access 320K byte floppy, communication and printer ports and 4 expansion slots are included.
- RAM-disk software.
- Includes MS-DOS<sup>1</sup>, GW BASIC<sup>2</sup>, PC Tutor<sup>3</sup>, and MultiMate<sup>4</sup> professional word processing system.
- Optional hard disk.
- Fully supported direct by AWA.

Corona PC's are available through AWA's continually expanding dealer network. For further information, ring AWA, or clip the coupon.

NSW (02) 922 3300	ACT (062) 47 7522
VIC (03) 529 4133	QLD (07) 369 3577
WA (09) 321 9334	TAS (002) 34 4532
SA (08) 79 9581	Auckland 76 0129

## AWA COMPUTERS

To: Corona PC Co-ordinator, AWA Computers,  
132 Arthur St, North Sydney, N.S.W. 2060  
Yes! Please send me more information on the powerful Corona PC.

Name: .....

Position: .....

Company: .....

Address: .....

City: ..... Postcode: ..... Tel: .....

memory for data files because you still have to save to disk – to protect them from a system crash. And when you use a package like Wordstar or dBase you only load it once. So if you load the file at the beginning or end of a computer session, it is still going to take as long. There might still be some advantage in the loading of the utility programs so that special routines execute faster.

Another possibility is that the extra memory could be used for multi-tasking; run one program in one area and flip across to work on another program in another area.

### Inside the Box

In appearance the 128K Microbee is little different from the Bees of days gone by. The box is much the same with its plastic look and plastic movement keyboard. The concept of ergonomics is not yet a reality in Microbee consciousness, though it will soon have to be if the Bee is to make a challenge for recognition as a serious machine.

The shape of the disk drives has changed. They now stand side by side, instead of stacked, so you can put your monitor on top of them. Whether that is a good thing to do to the disk drives remains to be seen. They are double-sided, double-density, 40 tpi, 13 cm diskettes with a capacity of around 400K each.

At the back of the machine are the expansion slots. On the left side is an I/O port, where you plug in your joystick (assuming business people have any use for one ...). Next comes the serial port, which supports peripherals like modems, followed by what is described as the expansion interface, into which the disk drives are plugged.

To the right of this last plug is a hole in the box marked 'user port'. This is just a gap without a plug, apparently provided so people can make their own modifications to the machine and have somewhere to install an extra plug.

At the very right hand side of the box is the power plug.

### Interfaces

On the whole these work well. The diskettes are reliable – ours showed

no errors or problems. The communications interface, using the Beemodem, worked like a charm. I have written numerous articles on the Bee and transferred them to the *Your Computer* system through the Bulletin Board, without any problems.

The human interface is the only bodgy one. There are plans afoot at Applied Technology to introduce a machine that will have a full ergonomic keyboard and much more stylish housing than the current almost substandard model. This will probably be designed to DIN 2197 specifications.

### Software

A wide range of software will run on the new Bee, including virtually all the software that runs on 64K Bees. Some excellent packages are actually supplied with the new machine, and these make it an even more attractive proposition.

In addition, there is some software that is unique to the 128K Bee. This takes the form of a more user-friendly interface between CP/M and the user. A shell presents the user with some standard options and the capability of choosing to run software without having to actually type the name of the software itself.

Icons are presented to aid in the selection of the more popular and commonly used packages, such as Wordstar, dBase and the communications package. The disk format option gives you a menu driven disk format utility; one that asks you exactly how you want the format to proceed without involving you in complex, apparently meaningless commands.

There are also user-definable options.

The communications facility is worth a special mention. This package gives you considerable control over the transfer of data without requiring any programming. The protocol for this is Modem 7.

The software packages supplied with the Bee include word processing, spreadsheet and database programs, and a number of financial management utilities. These last are from Sybiz Business Software and include general ledger, debtors ledger, creditors ledger, stock control, order

entry, invoicing, job costing, payroll and report generating.

You are also given access to the Microworld Support Library, and a couple of BASICs, Microworld and Microsoft, are thrown in. The total value of the software package is estimated to be around \$5000; the machine with the software actually costs around \$2000.

### Support

If the remarks around town are anything to go by, this has got to be the minefield in Applied Technology's landscape. Microbee has, according to some sources, a reputation for giving poor-quality support. Nevertheless, it should be made clear that some of the Microbee's competitors make Applied Technology look saint-like. Support remains something you should look at closely before deciding to buy.

Applied Technology is a dynamic, young company that is growing rapidly. As such, many industry people are interested in seeing it do well. However, many of the companies that have done so well in the mainframe industry only achieved success when they realised the importance of winning customers and keeping them. This depends heavily on providing a professional, efficient, and fast support service.

### The Verdict

The 128K Microbee package is one of the best *cheap* computer solutions around. If you are looking for a machine to do a little bit of data management, write the odd letter and juggle a few figures then this machine would do it very nicely. It won't take a very heavy workload, but it will sit there and serve a small, low-capital business well.

The 'bugs' I have mentioned are tolerable because of the market level at which the machine is pitched. What you pay for is what you get.

The advantages the Microbee 128K system offers are: a broad software base; some excellent supplied packages and utilities; and the fact that the Microbee is home grown. That means if you have a problem you can hassle the manufacturer right here in Australia. □



# COMPUTER OBSCOLESCENCE

## How we avoid it

### Will the computer you buy be the best next year?

Computers become obsolete at a frightening rate. You can wait (and miss out on the benefits) or buy a computer that will soon be a compromise. The Universe Supercomputer avoids this problem because it is continually being upgraded both in its **hardware** and **software** so that all existing owners benefit.

**How do we do it?** The Universe is based on World Standard S100 plug-in cards. All major innovations in microcomputer technology (such as 16 and 32 bit microprocessors) are available **first** on these cards.

**Plug-in improvements** As a Universe owner you can upgrade first. Universe owners were able to upgrade to 16 bit microprocessors (for under \$1,000) over 18 months before IBM or DEC released their PCs. By expanding rather than changing computers you keep all your existing software and data. No traumatic changovers, no waiting, no need to pay for a computer that's bigger than you need.

Compare the specifications of the Universe today:

**Runs both 8 and 16 bit, single and multiuser.**

All standard operating systems including CP/M & CP/M 86 with Multitasking, CP/M 8-16 'PLUS' (8 and 16 bit at the same time), MP/M 8-16 'PLUS' and MP/M 86 (Multitasking, Multiuser 16 bit with ultra high speed 10MHz processor).

An almost unlimited software base plus Multitasking up to 25 terminals, if and when you need them.

**Multiple Program Selection (MPS).** Our version of CP/M can swap between any mixture of up to ten separate programs almost instantly. Conventional computers only let you do one task at a time.

Memory may be expanded up to 1 Megabyte and disk storage up to 200 Megabytes. Start small and expand inexpensively as and when you need to.

Impressed? Astounded? Then call your nearest AED sales engineer for the whole story.



**Sydney:** 24 Darcy Street Parramatta  
(02) 689 1744. Telex AA 70664

**Melbourne** 53 Waverley Road, East Malvern  
Vic (03) 211 5542. Telex AA 30624

**Canberra** 217 Northbourne Ave., Canberra  
ACT (062) 47 3403. Telex AA 62898

# UNIVERSE SUPERCOMPUTER

When undertaking building projects, the planning for future needs of an expanding business in these competitive and demanding times is very carefully considered.

Labtam, in many ways follow this example during computer construction for their clientele. With Labtam, you can set up all your new software for 32 bit but you can still run 16 or 8 bit software on the same system.

A multi processor architecture is used to increase system throughput and performance.

Labtam Series 3000 Computer is an affordable, high performance computer built specially for real world processing applications to protect your investment in both hardware and software.

For further information contact:  
VICTORIA, HEAD OFFICE, 43 Malcolm Road,  
Braeside, Australia. 3195. Telephone: (03) 587 1444.

SYDNEY, Ground Floor, 2 Help Street, Chatswood,  
N.S.W. 2067. Telephone: (02) 411 2588.



# Another Labtam construction.

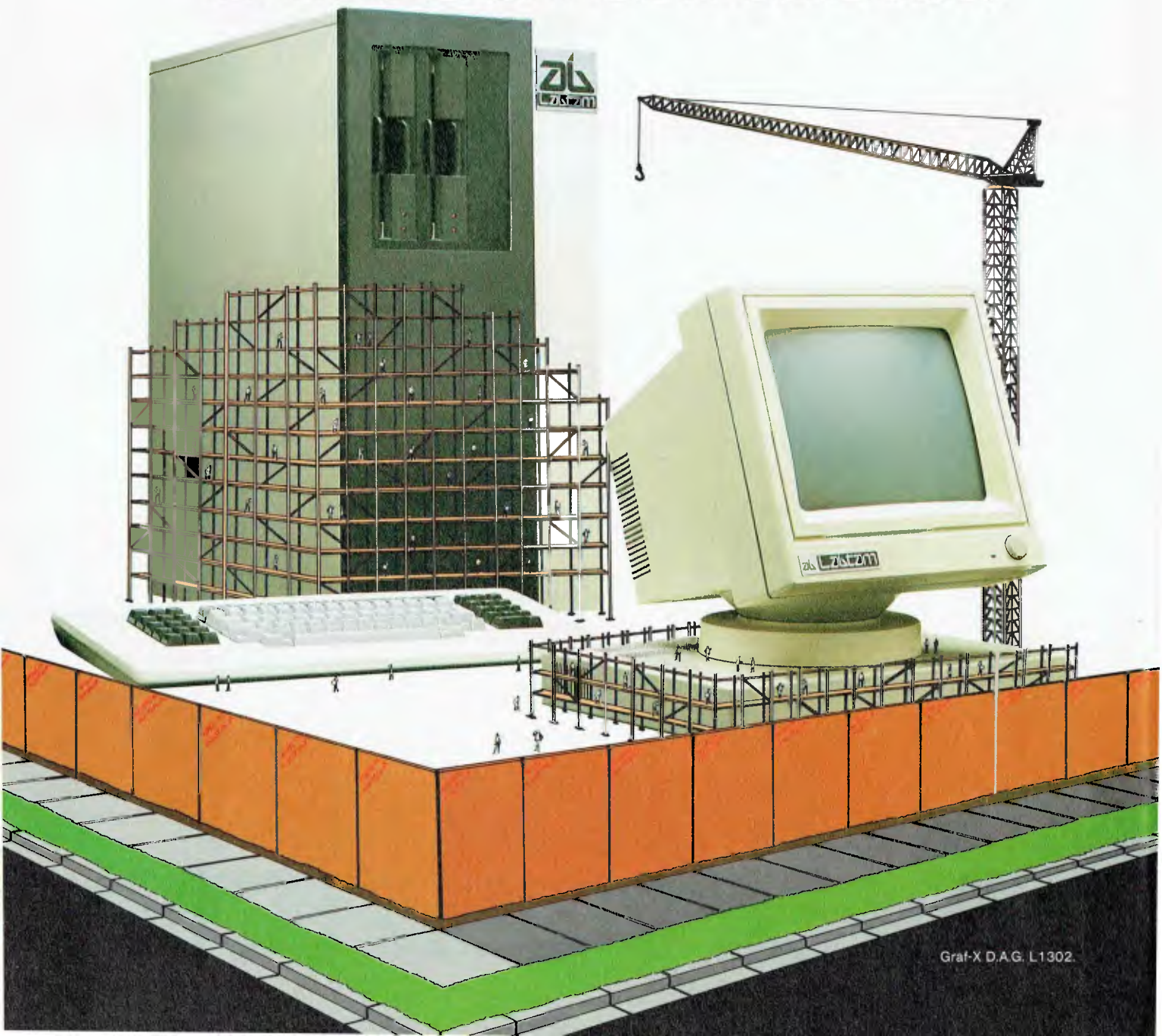

*Monitors are an item of computer hardware for which, generally speaking, you get what you pay for. Ritronics has released one at a very competitive price that would prove perfectly satisfactory for anyone looking at the lower end of the market.*

# Ritron monitor

By Evan McHugh

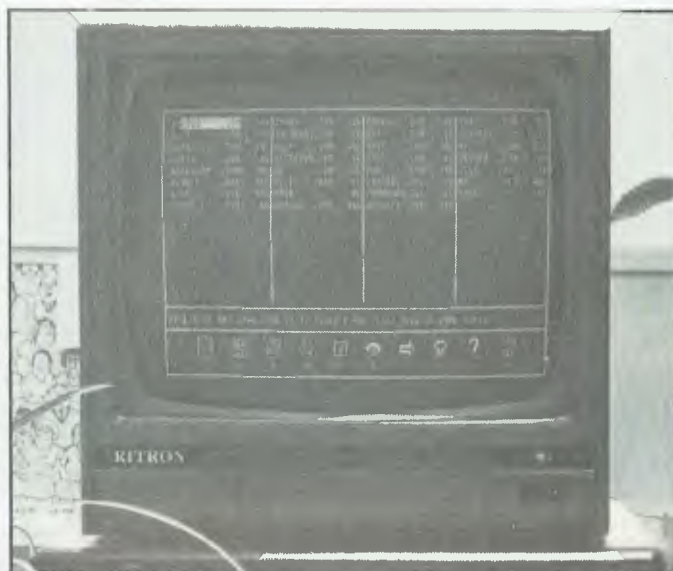

THE SCREEN of the Ritron monitor is treated to reduce glare and reflections, so that the overall impression is matt. Two types of screen are available; the usual green screen costs just under \$200, while the amber screen is \$230. The recommended colour to go for is the amber, not just because it is the latest trendy idea, but because the eyestrain caused by prolonged use of a monitor does appear to be less with an amber screen — when used correctly. The practice of turning the brightness up to full intensity will both increase the possibility of eyestrain and other physical problems, and probably destroy the monitor in a very short time. Set the screen intensity to complement the ambient light level; it saves both your eyes and the screen.

The monitor handles 80 by 25 with relative ease, although there is obvious separation of pixels on the vertical. Reverse video is legible but not pleasant, as the horizontals are much bigger than the verticals in the letters. Again, this problem is reduced by turning down the brightness, although it occurs frequently in many other monitors too, even in much higher price ranges.

The front panel of the screen is a low-glare grey plastic trim which gives a good contrast. At the front of the monitor, where such controls should be, is flip-down door containing all controls — including ones often stuck somewhere inside the box or inaccessible round the back. These adjust focus, horizontal width, horizontal

hold, vertical size, vertical linearity and vertical hold; there are also the usual brightness and contrast controls. As a consequence of these controls you are able to adjust the size and shape of characters to a high degree.

Flicker is not noticeable. There is a small amount of slewing and curve at the edges of the display, but this can be reduced through adjustment.

The on/off switch is also located on the front panel, just beside the door to the adjustment controls. A red light above the on/off switch indicates power status.

The monitor is a legless box, so there is no ability to tilt and swivel.

## Technical

The monitor has a vertical scan of 800 lines and a vertical pixel resolution of 640 pixels. The screen is just under 30 cm across the diagonal. At the rear of the machine is the video input and a video output which allows parallel connection of monitors. Both the input and output are BNC

sockets, and the housing is metal with a grey trim. Unit dimensions are 300 mm high, wide and deep, which makes it as much a basic box as it can.

## General Impression

In normal operation this machine is quite satisfactory. The screen looks good, and things happen quickly and smoothly. As such it is highly recommended as an all-purpose workhorse terminal.

However, we used it for a long period of time, and found a slight instability

(possibly a one-off fault in the review unit), so it would be as well to check the clauses of the warranty pretty carefully before buying. A small amount of pressure on the top of the box causes the screen image to disappear, and when the machine has just been turned on there is an occasional flicker if the machine bounces as you bang away on the keyboard. The suspicion I developed was that all was not perfectly well inside the box, so to avoid the inconvenience of having it croak on you one day with no possibility of comeback, check your warranty — and perhaps the availability of service and replacement parts.

In spite of this quibble, the Ritron is a good monitor. If you are looking for a flicker-free, all-purpose monitor in this price range, it is well worth considering.

You can get the Ritron monitor from two suppliers: Ritronics, 425 High St, Northcote 3070; and C-Tech, 48-50 A'Beckett St, Melbourne 3000.



# STAR WORDS



## WHICH PRINTER TALKS TO ANY COMPUTER IN THE GALAXY AND COSTS AROUND 30% LESS THAN IT'S COMPETITORS?

### Who else but STAR?

Character for character, the new STAR GEMINI family is the best value on the planet. A snappy 120 cps is yours for only \$449\* (10 inch paper) or \$795\* (15 inch paper).

And the GEMINI speaks all languages, be it Apple, IBM, NEC, T.I., Commodore ...

Just see your nearest computer retailer for a demonstration of the Gemini's many features — all included as standard. You'll be amazed at our paper feed system that includes friction platen and fully adjustable tractor feed. Or how about the variety of type styles and graphics — printable in the same line?

\*Please add sales tax when applicable.



---

## The Printer Range That's Taking The World By Storm

---

Distributed by



**Case Communication Systems Ltd.**

1-3 Rodborough Road  
Frenchs Forest NSW 2086

Telephone (02) 452 5231  
Telex AA72982

Lesley Zolin last wrote to 'Your Computer' cataloguing the trials and tribulations of an 'Innocent in Computerland'. Since then she's progressed in leaps and bounds, and now writes again to offer encouragement to all beginners.

# INNOCENCE REVISITED



The last time I wrote for these pages, it was as a break from the frustrations of finding what was the matter with a program in which I kept getting a 'SYNTAX ERROR IN 80' message. Nothing I did to line 80 would alter that message. Finally, I found the problem - in line 70. If you'd like to know what it was, you'll have to get in touch with me, and even then I may not tell (chortle). Just goes to show you need a certain kind of mind to communicate with these computers.

In my last article, I tried to explain that some unlikely people out here were getting to be fascinated by computers - me among them. That was partway through last year. The system I was using consisted of a Commodore 64 keyboard, a television set and a cassette recorder. It was only when I re-read the piece in the December issue of *Your Computer* that I realized how far the Innocent in Computerland had travelled in a few short months. I wrote about looking forward to a disk drive, a word processor and more experience with computers generally. Things certainly have moved in those directions.

This article was produced with the help of a word processor and was printed with a computer-linked printer (I hadn't even thought of printers!). The word processor software (Easy-Script) came on disk, and of course we needed a disk drive for that. Once the disk drive was installed, I learned how *fast* the thing is compared with tape. There are also such marvellous extra capabilities as being able to read a directory and select any program to be loaded - with no rewinds necessary. Truly, this was the stuff of dreams. It was fast, easy to use and could hold heaps of material.

Now all that information about disk drives is probably old hat to the majority of you, but remember that these words come from someone who is just learning what is available in the realms of 'Computerland'. I'm also learning what I know now and still need to know. For instance, a couple of weeks back I listened to a customer explain to a computer salesman that he wanted a machine >

for stock control, but that he did not want to use a disk drive. Tape was, he thought, sufficient. I looked smugly on, thinking what an innocent the poor guy was. I knew about disk drives and he didn't. I later realized that if I fouled up a simple 'load' or 'save' command on my own drive, I'd be in an awful mess. So much for smugness.

I digress. This is a tale of the journey of an innocent. On with the details.

### Growing Awareness

Things continued to progress. I'll remind you here that I am innumerate, middle-aged and female. To make matters worse, I'm a schoolteacher. Originally, when I was thinking in terms of filing systems and word processing for the writing part of my activities, computers didn't seem to have any relevance to my teaching. As familiarity with the computer grew, I became more aware of the uses for these machines in schools. It impinged on my consciousness that the school I was teaching at had a room-full of computer terminals. I started thinking in terms of using and writing educational software.

No, I haven't become a whiz-kid software writer overnight. It was just that I'd discovered a genuine reason for continuing to learn as much as possible about programming. For writing, the Easy-Script word processor is all that is really necessary. The software takes care of all problems with filing, writing, editing and the other details involved in turning out legible, acceptable hard copy. You don't need to know a thing about

programming to use it. When producing software, I would be the one writing instructions for the computer. The people at the other end of the monitor and keyboard wouldn't need to know anything about the workings of it, but would still get something out of it.

All these thoughts didn't take place in a vacuum. The engineer who had provided excuses for the original purchase of a computer was extending his own knowledge, branching out into more complicated BASIC programs, getting into Assembler, starting to talk about machine language, trying his hand at Pascal and generally continuing his love affair with the medium. Once more I was amazed at how much could be understood by someone (me) who had no training in what I had considered essential - maths. To quote that engineer (also an ex-lecturer of maths) on computer programming: "No matrices! Wow!". I concede I'm going to have to learn some of that stuff, but I doubt if it will be the painful process I would have feared at another time. That's probably because there's a reason to learn what would otherwise have been very esoteric stuff.

The combination of more knowledge, exposure to different languages, the acquisition of a disk drive and the goal of software-writing had me even further into computing. I tried GPascal and had more success than ever before with things like sprites. It became possible for me to attempt really interesting programs.

I went out and invested in the 'Pilot' software, which was supposedly designed to help people like me to

write the type of programs I was thinking about. After a couple of sessions with it, I gave up in frustration at the things it would not do. For example, it does not give full access to the disk drive while programming. I could find no way of reading a disk directory from inside 'Pilot', and once quitted, the language is lost until reloaded. Back I went to BASIC and Pascal to learn more about real programming.

### Onward And Upward

So here I am writing yet again to *Your Computer*. Once more I'm taking a break in the middle of a program. This time, it's not a syntax error I'm chasing. I have written a program in BASIC which includes a long delay while the computer goes about altering a hunk of memory. That delay might be OK for a 'toolkit' piece of software (even there it would be annoying), but something even mildly annoying is just not good enough. Machine language is the obvious answer. So, having tried out one routine which did not work, I'm building towards the second try. The programs I have been working on are still nowhere near an acceptable standard for anyone else to use, but with perseverance and time I think they'll be suitable for public use.

For now, I've got more learning to do, this time in the form of several languages. It's still great fun. Even with the increased 'sophistication' gained by my extended visit to the wonderland of computing, I'm still ready to leap about rejoicing when I press 'run[return]' and can truthfully say "It works!".

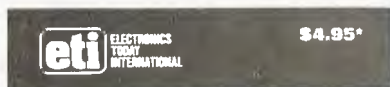

## TOP PROJECTS Vol. 8

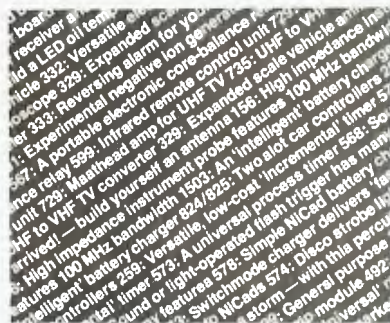

# THE VERY LATEST

Just one of our practical  
'Top Projects' series!

## TOP PROJECTS VOL. 8

Our 'Top Projects' series have always been very popular with hobbyists, containing as they do a collection of the best projects from the past year or so's issues of ETI Magazine. Here we have 25 projects, ranging from the ETI-1501 Negative Ion Generator, to the ETI-499 General Purpose 150 W MOSFET Power Amp Module, from the ETI-574 Disco Strobe to the ETI-469 Percussion Synthesiser, from the ETI-735 UHF TV Converter to the ETI-563 NiCad Fast Charger. Also included are the ETI-599 Infrared Remote Control Unit, the ETI-567 Core Balance Relay, the ETI-259 Incremental Timer, the ETI-156 100 MHz High Impedance Instrument Probe, the ETI-328 LED Oil Temperature Meter for cars, the ETI-257 Universal Relay Driver Board, the ETI-492 Sound Bender, the ETI-1503 Intelligent Battery Charger, the ETI-729 UHF Masthead Amp & more, & more.

Top Projects Vol. 8 is available at newsagents, selected electronic suppliers or directly, by mail order, from ETI Magazine, P.O. Box 227, Waterloo 2017 for \$4.95 plus \$1 post and handling.

NOW there is a REASON to buy a computer. Introducing ...

# Meta-4

## the Australian data base adventure

### A WINNER

WINNER of 1st PRIZE in the Business Division of the 1983 AUSOM\* Challenge programming competition, sponsored by VERBATIM (Australia) Pty Ltd.

META4 is a revolutionary new data base system which gives YOU full control of your computer with NO PROGRAMMING. No other Data Base system even comes near it. Now you can have an integrated Data Base system for your business or Profession for as little as \$395.00. META4 may be the only program you need to buy for your computer.

#### BASIC FACILITIES

META 4 is a comprehensive Data base Management system, including:

- FULL DATA BASE
- SIMPLE SPREAD-SHEET
- SIMPLE WORD-PROCESSING
- MAILING LISTS
- STANDARD LETTERS
- LABELS

#### THINK OF AN APPLICATION

META4 is suitable for a very wide variety of business, professional, academic and personal applications, such as:

<b>BUSINESS:</b>	QUOTES
CUSTOMERS	SALES
ORDERS	ACCOUNTS
INVOICES	NAMES
CREDITORS	ADDRESSES
LETTERS	LABELS
FINANCIAL	PRODUCTS
SUPPLIERS	PERSONNEL
CATALOGUES	ORG.STRUCTURE
DEPTS	
<b>PROFESSIONAL</b>	
MEDICAL	DENTAL
LEGAL	PHARMACEUTICAL
INSURANCE	FARMING
<b>ACADEMIC:</b>	STUDENTS
LIBRARY	SCORES
TIMETABLES	BORROWERS
BOOKS	AUTHORS
PAPERS	LECTURES
REFERENCES	
FORMULAE	
<b>INDUSTRY:</b>	REPAIRS
VEHICLES	PRODUCTION
MAINTENANCE	
<b>REAL ESTATE:</b>	ENQUIRIES
PROPERTIES	CLIENTS
ADVERTISING	COMMISSIONS
RENT	
<b>PROJECT:</b>	SCHEDULES
TASK LISTS	MEETINGS
DIARY	DOCUMENT'N
MANUALS	ESTIMATING
TIMESHEETS	
BUDGETS	

Information from any or all of the above applications can be AUTOMATICALLY LINKED & CROSS-REFERENCED, since META4 is a true Data Base system.

### 1. MONEY-BACK GUARANTEE

If you are not satisfied with META4, return it within 14 days for a cheerful refund. If you buy from a dealer, check he is prepared to do this before you buy.

### 2. TELEPHONE CONSULTING

If there is something you want clarified after you have purchased META4, ring us up. Maximum time for any one call 15 minutes.

#### BASIC CONCEPTS

META4 uses familiar concepts to aid you in it's use:

**ROOMS** — META4 has many rooms in it. Each room is used to store information about a different type of thing.

**QUESTIONS & ANSWERS** — when you go into a ROOM META4 asks you QUESTIONS about the type of thing (e.g. CUSTOMER, INVOICE, PRODUCT, etc) held in the ROOM, and stores away your ANSWERS.

**RECORDS** — META4 stores the ANSWERS to a set of QUESTIONS in a room as a RECORD. There can be many RECORDS in a room.

**DOORWAYS** — You can move from ROOM to ROOM through DOORWAYS. META4 automatically relates information in one ROOM to information in the next.

**BUILDINGS** — A building is a collection of related ROOMS and DOORWAYS. A BUILDING corresponds to the traditional concept of a Data base.

#### META4 IS PORTABLE

Any applications you develop under META4 will run without change on any computer that META4 runs on.

#### EASE OF USE

- SIMPLE and CONSISTENT
- HELP — 3 levels, for the current:
  - BUILDING you are in
  - ROOM you are in
  - QUESTION being asked.
- 3 TUTORIALS.
- USING META 4
- DESIGNING WITH META 4
- META 4 EXAMPLES

Designed from the ground up to be totally consistent, and as easy to install, learn and use as possible. You can quickly learn to use the system

#### META4 IS EXTENDABLE

All the features of the system are fully extendable to your own applications. You can add your own BUILDINGS, ROOMS, DOORWAYS and QUESTIONS. You can define your own maps, HELP text and tutorials.

#### WRITTEN IN ITSELF

Only META4 is powerful and elegant enough to use itself. All the system documentation is stored in standard META4 BUILDINGS, and printed out as a standard META4 report. When you use META4 to define a new application, you answer standard META4 questions in standard rooms in a META4 building.

#### DETAILED FACILITIES

- Menu driven
- True DATA BASE — RELATIONAL/NETWORK.
- Variety of Answer-types e.g. CALCULATED, DATE, YES/NO, NUMERIC, TEXT, LIST
- FULL PROMPTING
- Automatic VALIDATION
- Powerful Selection & Reporting
- All facilities fully EXTENDABLE to user's own applications.
- No programming
- Full DATA DICTIONARY defined as a META4 application.
- Automatic TOTALLING of lists.
- Automatic COPYING of ANSWERS from one room to another.
- Automatic MAINTENANCE of records in other rooms (Secondary Index facility)
- Copying of information to and from other products such as WORDSTAR.
- B-Trees ISAM Source Code in MICROSOFT BASIC.

#### DISK FORMATS AVAILABLE

5" IBM-PC DOS 320K  
5" APPLE-II CP/M 126K  
8" CP/M SS/SD 256K  
Other formats by request

#### MINIMUM HARDWARE REQ.

CP/M — Minimum 56K System  
IBM PC-DOS, MS-DOS — Minimum of 128K RAM.

APPLE-II — 64K RAM, 80-Column Card, CP/M card, 2 diskette drives.

#### Prices (inc. Sales Tax)

Manual alone .....	\$30.00
META 4 (CP/M) .....	\$395.00
META 4 (IBM-PC) .....	\$595.00
META 4 (MS-DOS) .....	\$595.00
Non-Standard Disk Conversion .....	\$50.00
Post & Packaging .....	\$10.00



BACK A WINNER! GO FOR META 4. ORDER DIRECT FROM:

SYSTEM SOLUTIONS PTY. LTD.

28-30 PALMERSTON ST, BERWICK VIC (03) 707 2851

OR FROM ANY OF THE FOLLOWING DEALERS:

VIC: ALPHA R & D (AUSTRALIA) 789 4656, COMPSOFT MICROCOMPUTER SERVICES (03) 428 5269, COMPUTERS 2000 (03) 781 4244, EMERALD HILL COMPUTER BROKERS (03) 690 8095, METROPOLITAN BUSINESS MACHINES (03) 383 2222, PRESIDENT COMPUTERS (03) 529 1788, ROBODCM (AUSTRALASIA) (03) 429 6233

NSW: J.T. MICROCOMPUTER SERVICES (02) 848 0452, THE COMPUTER WORKS (065) 553 5485

QLD: MERMAID COMPUTERS (075) 35 5511

WA: COMPUTER AGE (09) 384 1111 SA: COMPUTER MARKETING HQ (08) 260 2440

\*Apple Users Society of Melbourne

*Cries of alarm went up from the conventionalists when Widgee Shire Council introduced a computer to its sale-yards. However, as Leigh and Barbara Hemmings report, even the diehards are having to admit that computerisation has made the system both fairer and faster.*

# This little Sirius goes to market

THE SUN beat down on a group of Australian men engaged in a time-worn practice. Like punters over the last fifty metres of a race, their eyes never left the caller, and the caller's eyes never left them. To an outsider, amongst the group not a gesture was discernible. Nothing, save a slight movement of the eyelids, the barest flicker of an index finger or faintest tremor of the head. And yet the caller continued with remorseless haste, keen no doubt to progress on to the watering hole at the end of the day.

"46.5, 47, 47.5, 48, 48, 48 – SOLD at 48 cents!" came the cry of the auctioneer. On to the next pen of cattle they moved. Queensland cattle buyers rubbing shoulders with vendors - high boots, low-slung hats and big cheque books.

If we could zap back in time that same scene could have been recorded fifty or a hundred years ago; drays instead of cars maybe, but essentially the same. The modern-day difference to this cattle sale at Gympie (200 km north of Brisbane) was situated in a small air-conditioned room barely shouting distance from the cry of the auctioneer. Inside was the familiar hum of a CPU fan, and the peculiar clack of a keyboard being worked. The computer has come to market.

Inside the room a keyboard operator paused, fingers poised over

a Sirius 1 computer coupled to an Avery Tension Load Cell, waiting for the next pen of animals to arrive. Once the final call is made out in the yard and the buyers move on to the next pen, the yardmen move the sold cattle towards the weighing area. Dockets are recorded by the auctioneer's offsider at the time of sale, listing the vendor, buyer, price/kg, and are delivered prior to the cattle arriving for weighing.

Specifically, what we have here is an Avery Digital Computing system, utilising a high-capacity (10,000 kg) Type 8787 load cell connected to an 8650 Digital Indicator, which gives a LED display of weight to the nearest 5 kg. A parallel BCD output from the digital indicator provides a weight signal link to the Sirius 1 computer (128K, dual drives, single-sided, 600K per disk). The Sirius 1 is linked to a Toshiba dot matrix printer, which provides a complete printout of all proceedings. The software system, 'Equinox Liveweight Sale', was developed by Equinox, a Brisbane-based firm.

## Onto the Weighbridge

As soon as the cattle arrive the entry door is raised by remote control and onto the weighbridge they come. "Shoulder and loin, black and white heifer Number 61", comes the call.



A fictional interpretation of a bovine raspberry.

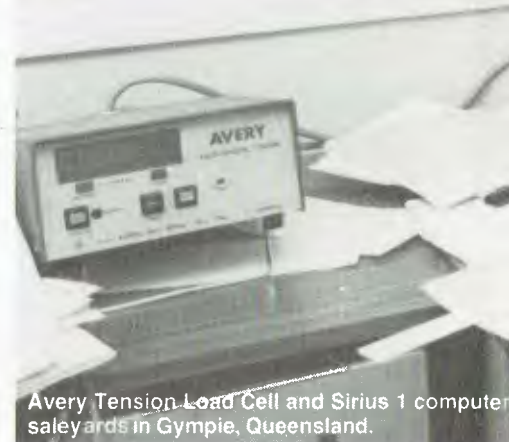

Avery Tension Load Cell and Sirius 1 computer saleyards in Gympie, Queensland.

Thus the beasts are identified and correct data entry can begin as the cattle pause on the weighbridge. Using specially programmed alpha codes the operator uses a minimum of keystrokes to enter agent, vendor, buyer, lot and pen number, brand, cattle type and breed, price per kg, the number of head – about nine seconds for the complete entry.

Up to this point the digital indicator beside the operator is giving continual readouts of the total weight of cattle on the weighbridge. At the point when the operator presses ENTER, the load cell takes over and enters weight, average weight, price, and average price. It then asks 'okay?'. The information is read off the screen and broadcast over the saleyard's public address system to inform buyers, sellers and the general public of the exact weight and price.

As soon as the operator hits RETURN the data is both recorded



In operation at the Widgee Shire Council

on disk and sent to the printer, which immediately produces a hard copy.

The actual weight cannot be entered or changed by the operator. The only mistake possible is to enter the wrong selling price, but as both buyer and seller keep a keen eye on this the mistake can be quickly rectified, allowing the system to recompute the final price. All amendments and cancellations are logged on the printer. New buyers or missed vendors can be input during the sale – while the cattle are actually being weighed if necessary.

Following the sale the Equinox system provides hard copy of weighing dockets, buyer accounts, waybills and a complete summary of sales including gross turnover for the sale. The system calculates fees based on an agent commission of the total value by vendor. Yard dues, a classing and penning fee and saleyard accounting levy are all calculated per head.

### Cries Of Alarm

When Widgee Shire Council decided to introduce computerised live weight selling at their saleyards there were the usual cries of alarm. Well-known local livestock agent Gene Barker described the alarmists as the same people who would have expected the world to be destroyed by the invention of the shang-hai. He felt the computerised system was fairer to all concerned, would be faster (when everyone was used to the system) and certainly cut down on paperwork.

Depending on how quickly the humans can recognise which beasts are on the scales it takes as little as 20 seconds to enter all the data, weigh the cattle, save it to disk and print out the results.

The Thursday sale attracts interest from a wide region, with between 850 and 2000 cattle being handled during the day. This means a gross turnover of up to half a million dollars. As

each sale is successfully handled, the peculiarities of the Gympie Sale are allowed for in program maintenance – the maximum number of buyers has been upped to three hundred and the maximum number of weighings to 1000.

As the growing pains are overcome, everyone involved with the sale is coming to understand just how much better things are with a computer in attendance. However, it will probably take a while longer for the idea to die that it's better to get your cattle weighed at the end of the day than the beginning. Often, as a beast passes over the scales, it leaves behind a reminder of its presence, a calling card you might say. The idea is of course that as the day progresses the fresh manure adds to the overall weight. Sadly for the storytellers this is not the case. The load cell is constantly recomputing the weighbridge weight so there are no heavy-in-the-afternoon cattle at this market. □

# HARD DISK — SOFT PRICE

THE MORROW MICRO DECISION WAS CONCEIVED AS A COMPUTER AND SOFTWARE PACKAGE TO FILL THE NEEDS OF SMALL BUSINESS AT A COST EFFECTIVE PRICE.

IT HAS MET WITH WIDE ACCEPTANCE IN THIS ROLE BUT AT THE SAME TIME HAS WON THE ACCLAIM OF AN INCREASING NUMBER OF PROFESSIONALS AS A PRODUCTIVITY TOOL.

CAPABLE OF EASY INTERFACE TO DATA CAPTURE EQUIPMENT, DIGITISERS, PLOTTERS AND THE LIKE IT IS HELPING INCREASE THE EFFICIENCY OF SURVEYORS, ENGINEERS AND SCIENTISTS.

*NOT JUST HELPING TO **COUNT** THE DOLLARS BUT ALSO TO **MAKE** THEM.*



MORROW 

FROM **AUTOMATION STATHAM** PTY. LTD.

47 BIRCH ST BANKSTOWN  
NSW 2200 (02) 709-4144  
TLXAA73316

**A FULL SERVICE MORROW  
DISTRIBUTOR SINCE 1976**

**ASSCO** PTY. LTD.

153 ELEY ROAD, BLACKBURN  
VIC 3130 (03) 233-6355  
TLX. AA 30333

**VICTORIAN & SOUTH AUSTRALIAN  
SALES & SERVICE**

*A few years ago bionic body parts were solely the stuff of TV melodramas. Now, according to Dr Eugene Sherry, microelectronic technology is changing the very idea of the human body.*

# HI-TECH HEALING **Part 2**

MICROELECTRONIC technology has found its most widespread applications in the mutually exclusive areas of military defence and clinical medicine. Though these two could never be lovers, they are bedfellows through the same high technology that has spawned the means to destroy human organs and limbs, and just as easily replace them with bionic equivalents.

As a result the human body has become quite disposable. Biomedical engineering is now the darling of the health and physical sciences; funds and energies are pouring into research and development in this engineering field, and Wall Street is taking stock of its seemingly endless commercial possibilities.

Think of a human organ or structure and chances are that an equivalent artificial part is already available or well on in development: artificial skin, blood, bone, joints, hearts, kidneys, blood vessels, electronic hearing and vision, microelectronically driven limbs, intra-ocular lenses for the eye and miniature pancreas-like pumps — suddenly the notion of bionic man doesn't seem so far-fetched.

"By the turn of the century, every major body organ except the brain and the central nervous system will have artificial replacements," says Dr William Dobbelle, Director of the Institute for Artificial Organs in New York City, which is working on replacements for the pancreas, heart, ear and eye.

Dobbelle has spent the last fifteen years developing artificial or electronic vision for the blind. This intriguing ▶

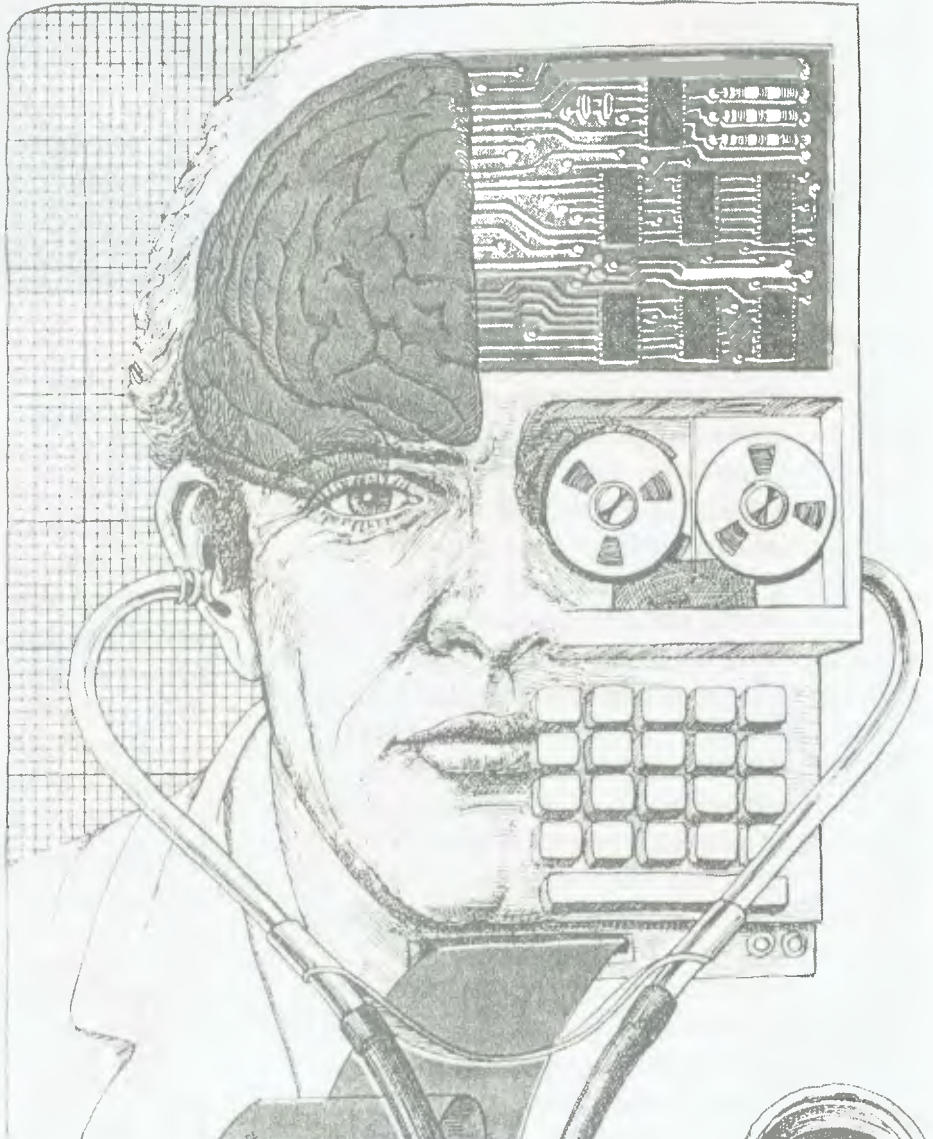

# People are going for Friday!™ like there's no tomorrow.

Friday! is the new electronic file handling system that has become an instant best-seller in America because it's so revolutionary.

Within two weeks, it broke into the Top 20 on the sales chart of Softsel, one of the country's leading computer software distributors.

And it's now well on its way to the top.

## **The Friday! phenomenon is simple.**

Friday! uses simple menus and talks to you in plain English, so almost anybody can use it.

It's great for sales and commissions, clients and portfolios, mailing lists and labels, invoices, inventories, paycheques, reports and more. And it works with other microcomputer software like 1-2-3™ and dBASEII® (our own advanced database management system).

It comes with a complete, step-by-step tutorial, but you can set up an "electronic file" without even looking at the manual, then use it at the touch of a few keys.

Friday! finds any filed information in seconds. Computes totals, subtotals, commissions, etc. Prints form letters and mailing labels. Gives you quick reports from



all or part of a file with a few keystrokes. Or if you need a special report for your bank or board of directors, just "paint" the format on your screen, then have Friday! do all the work.

And while Friday! does more than file handling systems selling for as much as \$650 it's yours for just \$333 (recommended retail price)!

Contact your dealer for more information. Arcom Pacific, master distributors for Friday! (07) 52 3862. Dealer and distributor enquiries welcome. Call us for the name of your nearest Friday! Computer Store.



**ASHTON · TATE** ■

# HI-TECH HEALING

development has involved implanting electrodes in the visual cortex of the brain; computers connected to the electrodes then transmit impulses to the brain, and the patient 'sees' starlike impressions called phosphenes.

This artificial vision device is a teflon matrix containing 64 platinum electrodes, placed on the surface of the patient's visual cortex. The wires from the electrodes pass between the scalp and the skull, emerging through the skin behind and slightly above the ear, where they are connected to a non-toxic, non-corrosive carbon pedestal. The whole portion protruding through the skin is no bigger than a five cent piece. One of the first blind volunteers, who was blinded ten years earlier in a gunshot accident, was able to detect white horizontal and vertical lines on a dark background

after he was 'wired up'.

With all the hardware external to the body, new refinements in electronics can be made easily and reliably as required.

Eventually, Dobbelle and his co-workers hope to put a micro-miniature TV camera in a glass eye attached to the eye muscles. The camera would transmit incoming visual signs to a tiny computer lodged in the frames of a dummy pair of glasses, and on through the wires to as many as 512 electrodes on the visual cortex. Even with this futuristic device, the best vision that can be obtained will approximate the blurry black and white images of the TV transmissions sent back from space by the early astronauts.



Cochlea implant project leader, David Money of Nucleus.

Because stimulating the brain's visual cortex makes blind people 'see' spots of light, scientists hope to create an artificial vision prosthesis out of a tiny television camera in a glass eye and a microcomputer in a pair of dummy

glasses, connected by wires to electrodes implanted in the brain.

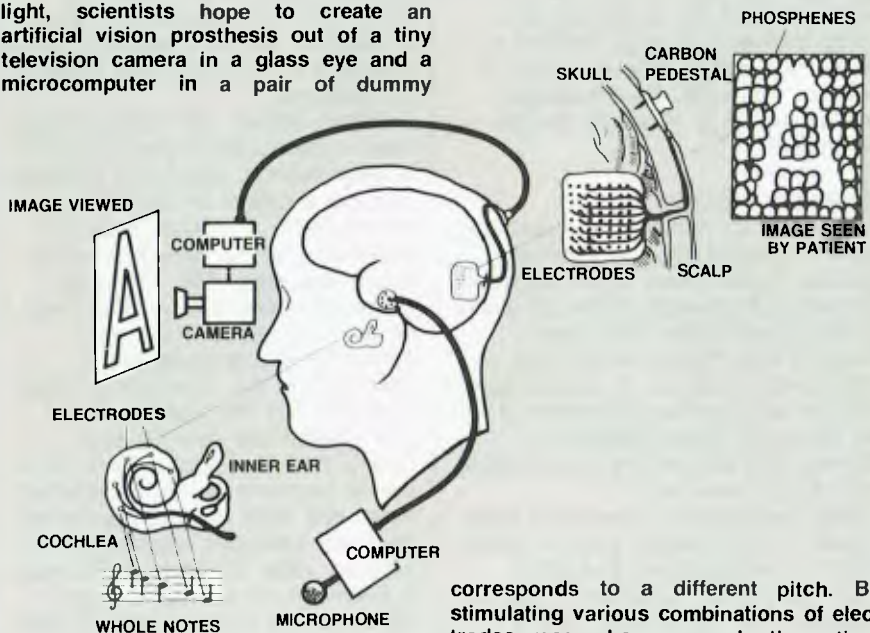

An experimental device that may enable the deaf to hear depends on tiny electrodes implanted along the spiral-shaped cochlea, or inner ear, where each location

corresponds to a different pitch. By stimulating various combinations of electrodes, researchers can make the patient perceive large changes in pitch. Wires from the electrodes pass between the scalp and skull, emerging through the skin behind the ear to connect with a microphone and computer.

## Ears, Eyes, Hands, Blood...

Artificial hearing is already available and was developed in Australia. Work on the micro-based system was first started over ten years ago at Melbourne University by Professor Graham Clark. The University and the Victoria Eye and Ear Hospital continued work on the project until 1981, when the Department of Science and Technology let a two million dollar contract for its commercial development to a Sydney-based medical equipment manufacturer, Nucleus Ltd. Under project leader David Money, an electrical engineer, the implant has now been fully developed and a number of cochlear prostheses have been installed in both Australia and the USA.

According to Nucleus, the system is the most advanced of its type, and at \$10,000 per unit, far from the most expensive.

The unit translates sound in electrical impulses carried to 22 electrodes implanted in the cochlea of a patient whose links between the inner ear and the auditory nerve have been irreparably damaged. At present only those patients whose deafness has occurred subsequent to birth can be assisted, because the device has to be tuned in accordance with what implant patients say they can hear.

Nucleus is closely involved in the development of many other high-tech health care equipment such as cardiac pacemakers, bone growth stimulators and diagnostic ultrasound.

The pacemaker is an implantable device, enclosed within a hermetically sealed titanium container to prevent leakage into the body's fluids, and includes integrated circuits with several hundred transistors. The pulse generator is connected to the heart by a lead passed through the arteries. Whenever the heart slows or

develops irregular rhythms the pacemaker takes over to maintain an even physiological heart rate. Further sophistication of these devices is towards implantable defibrillators, which will convert patients out of dangerous arrhythmias such as fibrillation (which causes heart attacks), by delivering a recovery shock to the heart.

The bone growth stimulator is an electrical device for improving the healing process of fractures. The implantable device using the same technique as the cardiac pacemaker passes an electrical current across the bone endings to stimulate callus formation.

There are probably about 20,000 cataract operations in Australia every year. Lens implants have been used for the last twenty years, but it is only in the past few that their use in patients with cataracts has increased from ten to fifty per cent. It is a long way from the technique used in India two thousand years ago, when the travelling medicine man struck the side of the patient's head with a large rock to dislodge the opaque lens. They either had a fifty per cent improvement in their vision or else had a large intraocular haemorrhage; either way he had collected his fee and was busy at work in another village by this time!

The original idea for lens implants came from a British surgeon who observed that during World War II, fighter pilots received no damage to their eyes from bits of plastic off exploding objects. He designed what was believed to be the first plastic lens implant, which is regarded as being one of the main advances in eye surgery this century. With a lens implant *in situ* the patient is able to see within a few days after the surgery.

The first powered prosthetic hand came to Australia in 1966. It was driven by an electric motor worn in a belt pack along with batteries. A 1980 myoelectric (muscle electric) hand has the electronics and power pack contained within the prosthesis and the wearer is free from the cables and harnesses. Using biofeedback, amputees are able to learn to control the device much as they control a normal limb. Fundamental research is being done at the Nerve Research Centre at the University of New South Wales to find out how nerves connect with muscles and pass signals, as the ideal is to have artificial limbs controlled by nerves.

Blood substitutes may soon be marketed widely. Created from perfluoro chemicals, artificial blood

has been limited in use up to now by the Food and Drug Administration (in the US) to Jehovah's Witnesses, whose religion prohibits conventional blood transfusions. But Japan's Green Cross Corp expects to start mass producing its version (FluosolDA) this year. The milky white substance has no antibodies, platelets or carrier proteins, and it is not intended to completely replace whole blood. But it does have a remarkably high ability to carry oxygen and carbon dioxide to and from the body tissue. As a result, it could be used to aid stroke victims or those with sickle cell or aplastic anaemia.

It will be especially valuable in Third World countries where there are few blood banks. In Australia it will be particularly useful for blood replacement where there has been sudden and massive blood loss, as in car accidents or major haemorrhage; this is vital in the present climate of blood shortages and fears of contamination of blood bank stocks from hepatitis and AIDS.

Artificial kidneys (renal dialysis units) are in widespread and accepted use throughout the western world. Further development here is concerned with reducing the size of these machines, which are normally maintained in hospitals and so limit the lifestyle of the dialysis patient, who must have three two-hourly sessions a week to stay alive. Portable units using the body's peritoneal cavity (the blind sac beneath the skin surface and in front of the intestines) are being marketed, allowing patients to dialyse themselves wherever they may be. The units are disposable and so the major haunt of infection is eliminated.

### Research Mecca

The mecca for research and development in biotechnology in Australia and the Pacific Basin is the Centre of Biomedical Engineering at the University of New South Wales. The major thrust of their R&D is in the area of orthopaedic hardware. In collaboration with the orthopaedic department of the Prince of Wales Hospital in Sydney, they are working on perfecting the artificial knee joint.

Joint replacement surgery has been around for over twenty years – about 5000 hip replacements and 2000 knee implants are done each year in Australia. The hip artificial joint is almost perfect in design and operation – patients previously crippled with arthritis or from motor vehicle accidents are now able to ambulate with little if any pain. The knee joint poses more problems, the major one being

fixation of the artificial joint in the bone matrix.

The artificial joints are put in using cement to allow the joint to stick to the bone. However, this cement can crack and fragment with time, allowing the joint to work loose, and so the patient loses a lot of stability. In collaboration with the CSIRO surgeons the researchers are looking at the use of zircon-based ceramic, which can be made porous so the bone can grow into the surface of the new material. The implant so becomes anchored by living material tissue as opposed to the cement in conventional replacements. An American company, Howmedica, has introduced its porous metal knee joint into this country, which is already being placed in patients and promises to revolutionise knee replacement surgery.

The NSW Biomedical Engineering Department is investigating the concept of zenografts – zeno meaning foreign – for replacement of ligaments, which connect bone to bone, and tendons, which connect muscle to bone. It is using tendons from animals which have been chemically treated so they will not be rejected by the body's immune system. Results are so far good. The material can be reabsorbed by the body and used in reconstructive surgery for ligaments in the knee, and most likely certain tendon replacements. Again Nucleus is planning to market the product in six to twelve months. The potential use of this artificial tendon replacement is widespread, such as in replacing torn or destroyed cruciate ligaments in the knee from sports or car accidents.

Denton Cooley, the famous Texas heart surgeon, would say that the artificial heart is *passé*. He implanted one into a patient in the Sixties – it was probably a premature clinical experiment as the patient survived only a few days. Still, the much publicised Jarvik total artificial heart – an air-driven pump made of polyurethane and aluminium – developed at the University of Utah, implanted into the Utah dentist in 1982, lasted just over 60 days. Clearly there is a long way to go in the development of the replacement heart, and most medical pundits say the heart transplant operation in Stanford under Dr Norman Shunway is becoming so successful and reproduceable that the artificial heart may not be required.

Most large shopping centres in Sydney or Melbourne would have shoppers walking around who have implanted artificial blood vessels or middle ear plastic ear bones (called

the stapes). Artificial blood vessels made out of polyester are used extensively to replace diseased and clogged arteries in the leg, abdomen and the chest. The stapedectomy operation which replaces the stirrup-shaped bone in the middle ear is commonplace, so restoring hearing to patients deaf from otosclerosis (excessive bone growth).

Perhaps the most exciting development in biomedical engineering, and the one that will have the greatest impact on our health, is in the area of genetic engineering – the biochip.

### Fine-Tuning the Body

Genetic engineers believe they can fine-tune the human body to eliminate a lot of congenital and acquired defects. It's far-reaching scientific rhetoric, but some animal and plant results are already in. By harnessing the replicating apparatus of bacterial genes, namely the intra-cellular DNA molecules of the bacteria, scientists are able to 'fool' the bacteria, usually the E coli variety, to reproduce certain chemicals such as insulin and various pharmaceutical drugs, such as interferon (for viral infections) and antibiotics. Utilising bacteria to manufacture chemicals is a lot more efficient and less expensive than

using standard chemical synthetic techniques at present used by drug companies.

Further sophistication of genetic engineering techniques should allow us to alter the genetic structure of the human cell, so eliminating certain congenital diseases which have been programmed from birth to occur, for example sickle cell anaemia in the US black population. Already scientists in Flinders have been successful in eliminating sickle cell genes from affected mice populations.

Ultimately, the goal is to develop the biochip, which is the organic equivalent of the silicon chip, made up of protein molecules which are far more complex than silicon and can store and process a great deal more information. This means that more efficient and compact chips could be produced, the size of single molecules, with thousands of times the computing speed of the smallest chip.

The first biochip was made in 1974 by IBM and New York University; however, it was unstable and IBM lost interest. Work in England has rekindled interest. A team from Warwick University led by Dr John Barker has managed to implant a simple biochip in the body of a man with heart disease to monitor his

## HI-TECH HEALING

beat. It is made of conventional semiconductor materials, but is specially coated to respond to the biological environment and can pick up tiny changes in the calcium ions associated with the muscle of the beating heart. The concentration of the calcium changes with the rate of the heart beat.

With further development it is expected that biochips could be implanted in the blood to detect imbalances of hormones, enzymes or insulin and act to correct them. Some believe that a chip implanted in the spinal cord of a paraplegic should be able to pick up tiny electrical signals and turn them into instructions to move the paralysed limbs. The biochips also promise to be used to provide artificial intelligence systems for robots.

Clearly high-tech healing has arrived, determined to upmarket man's own image of himself. □



# magma media – The World's Finest Magnetic Media



D.E.I. data cartridges



Graham magnetic tapes



If your not using these products, you're not using the best.

- Xidex Precision flexible disks exceed all known industry standards.
- Graham magnetic tapes, with revolutionary new binder and magnetic particle is State-of-the-Art.
- D.E.I. data cartridges are individually certified and guaranteed.
- Tick the appropriate boxes, complete the coupon, and post TODAY for further information.

Name: \_\_\_\_\_

Company: \_\_\_\_\_

Address: \_\_\_\_\_



Sydney: (02) 428 1100, Melbourne: (03) 699 9688, Brisbane: (07) 229 1600, Canberra: (062) 47 2322, Perth: (09) 328 3311, Adelaide: (08) 223 6261.

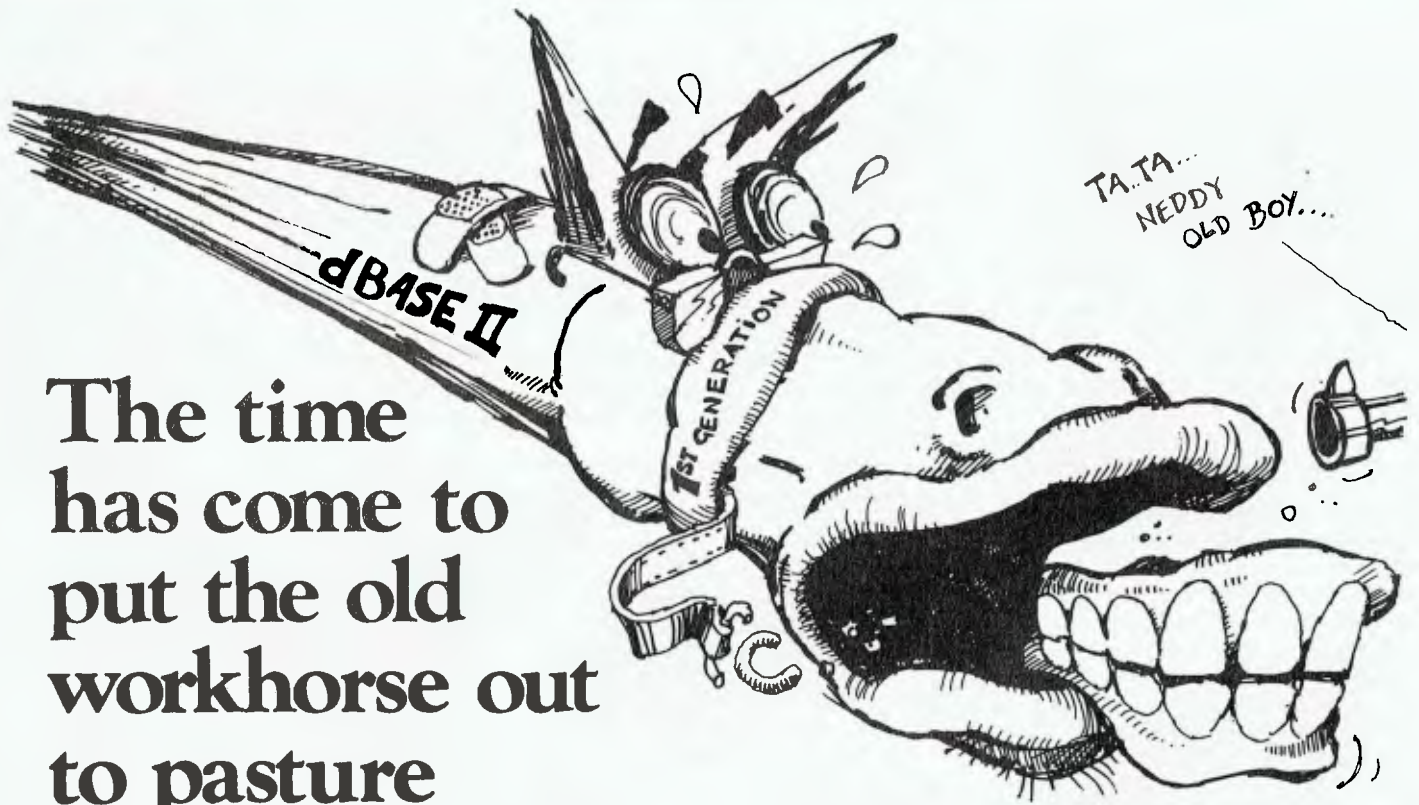

# The time has come to put the old workhorse out to pasture

The days when dBASEII\* stood all by itself at the apex of the database management pyramid are past. The old workhorse has been put out to pasture by a new breed of faster, easier, more powerful packages. It's not that the old horse hasn't done its job: it has, gloriously. Those of you using dBASEII know that it has paid for itself many times over. In its time it was The Best. And now there's no denying that it's slow, it's cumbersome, it's difficult to live with — when you compare it with some of the newcomers on the market.

## Fresh out of the starting gate.

So who are the newcomers that have usurped the old master's position?

### Delta:

We regard it as the most complete user-oriented database system on the market today and for the foreseeable future. Delta caught our attention when it received the UK government's prestigious RITA award for "best software of its kind", followed closely by IBM UK's adopting it as their own distributed product for the IBM PC. Everything we have learned about it since working with it here has served only to increase our enthusiasm. Delta has so much to offer — and you don't have to be a programmer to get it all.

### Dataflex:

Dataflex is a true multi-file, multi-user database management system. "Flex" offers you unlimited flexibility in the development of high quality, easy to use database applications — in a minimum of time. "Flex" is for software developers everywhere, as well as for users with complex applications.

## \$\$\$'s for your old nag.

So it's off to the glue factory with dBASEII. For a limited time\*\*, Intelligence is prepared to help you with the cost of replacing your dBASEII system. If you turn in your old copy of dBASEII on a new Dataflex, we'll give you a trade-in value of \$200. If you choose Delta, we'll make it \$150.

(No, to tell the truth, we won't get a lot of glue out of the oldtimer. Our aim is simply to tantalise you into finding out just how good Delta and Dataflex really are.)

## Place your bet on a winner.

Delta and Dataflex are available at leading computer stores everywhere. Ring up your local dealer and ask him for a demo. If he doesn't know about the product you're interested in, ring us. Or better yet, have your dealer ring us. It's time he got on the inside track.

\*copyright Ashton-Tate. \*\*Offer holds until June 30.

Delta and Dataflex distributed in Australia by

**Intelligence**  
(AUST. PTY. LTD.)

**Sydney:** 4th Floor, 204 Clarence Street, Sydney, NSW 2000.

Phone (02) 267 1711. Telex: MNC AA25026.

**Melbourne:** Suite 303, 620 St Kilda Road, South Melbourne Vic 3004.

Phone: (03) 51 1406 Telex: AA39219.

**Brisbane:** (07) 343 9122

## LSI Killed the Video Board

By Eric B Lindsay

THERE IS NO doubt that one of the areas in which specialised chips have improved microcomputers is in the video display. I once put together a video terminal that displayed some 20 or so lines of 32 characters, and the board involved 30 or more TTL chips, and much cursing and frustration.

I was reminded of those no-so-long-ago days when I read Don Lancaster's 'The Cheap Video Cookbook' (Howard W Sams and Co, Indianapolis, 1979). This book tells how to replace those complex video display boards with a seven-chip design, and do all the rest of the work in software. The design is ingenious, suits 6500 and 6800-type microprocessors, and gives a really flexible, cheap display. The specific design given is for the KIM 1, but there is obviously enough information to adapt it to many other existing micros.

The thing is, no one in their right mind will use this method these days; the reason for this will become clear in the next book reviewed. Despite this, I recommend this book highly because of the amount of otherwise unobtainable material on modifying and amending televisions and monitors to suit microcomputers.

First, there is an explanation of the usual method of converting a standard portable TV into a monitor (this is similar to that used by stores like Dick Smith, except you can still use the set as a TV, and you can buy a suitable TV at Woolworths for \$89 instead of paying \$149 for a monitor).

Second, there are details of what the sound trap is, and why removing it improves the performance of a converted TV.

Third, there is information on simple modifications to extend the horizontal hold time to make the TV more suited to 80-character displays.

Fourth, you can reduce the width of the display so that characters do not get lost off either end of the screen. For this section of just one chapter the book is worth the \$8.95, especially when you consider that you can save \$60 by doing your own video conversion.

The reason Don Lancaster's methods

are obsolete can be seen in the 'CRT Controller Handbook', by Gerry Kane (Osborne/McGraw-Hill, Berkeley, 1980). This text is intended as a stand-alone supplement to the Osborne 'Introduction to Microcomputers', and covers some video display chips. There are 35 pages of rather terse detail on how CRTs work, and how this style of chip works, and then detailed cover of the DP8350, 8275, 6845 (as used in the IBM-PC), 6545 (as used in the MicroBee), and 5027.

I would like to have seen this book available in Australia somewhat sooner, as the edition I have does not cover several support chips that are used in modern micros. The 8002 chip used in the Ferguson Big Board, version II, is missing, for example.

Despite this, if you happen to have a microcomputer that uses any of the chips mentioned, and you want to know how to control that chip, this is the only book that covers the topic. I must, however, mention that it is not a suitable text for beginners, and you may waste your \$6.99 if you expect instant easy answers to graphics display problems.

There is one major disadvantage to this style of text that does not apply to the Lancaster book, which is that it is based almost entirely on a close reading of the manufacturers' data sheets, rather than on use of the circuits in question. As a result, where the data sheets are incomplete or, worse, inaccurate, so are the texts based on them.

For example, the diagram on page 4-20 shows the outputs of 6845 registers R0 to R3 as being their contents plus one, whereas this does not seem true of R1. There is considerable confusion in the details of the interlace and non-interlace scan bits for the 6545, no doubt because there are three sources (the book lists only Synertek and Rockwell, and not Commodore MOS), all of whom make slightly different claims in their data sheets.

Since diagrams are usually labelled by a typesetter separate from the proof-reading, there are some errors in this area. On page 4-21 the 6845 Hsync Position Register R2 is called the Width Register. Despite these problems, the book is much easier to follow than most of the data sheets. □

## DIGITAL SOUND PROCESSING APPLE II

The DX-1 Sound Processing System is the result of painstaking research and development by the Decillionix Corporation in Silicon Valley, U.S.A. With this amazing new product you can record, process, and playback **real** sound. **Real** sounds can be modified under computer control in ways never before possible.

While other systems 'generate' and produce 'computer' sound, DX-1 allows you to enter, save, process, sequence and play **real** sound entered directly by a microphone or another source.



Ask for a demo tape and information sheet now (\$3.00) and convince yourself of the incredible capabilities of the DX-1.

**DX-1 System \$320**

+ \$5 pack/post

(includes all software and hardware)

Thinking  
Systems

Sole Australian Distributor

P.O. BOX 260 CAMMERAY,  
N.S.W. 2062

Ph: (02) 90-6868

Dealer enquiries invited.

*Eric Eulenstein was an early Microbee hacker; we thought his experiences in eliminating error messages could be useful for others.*

# Option-not-fitted Syndrome

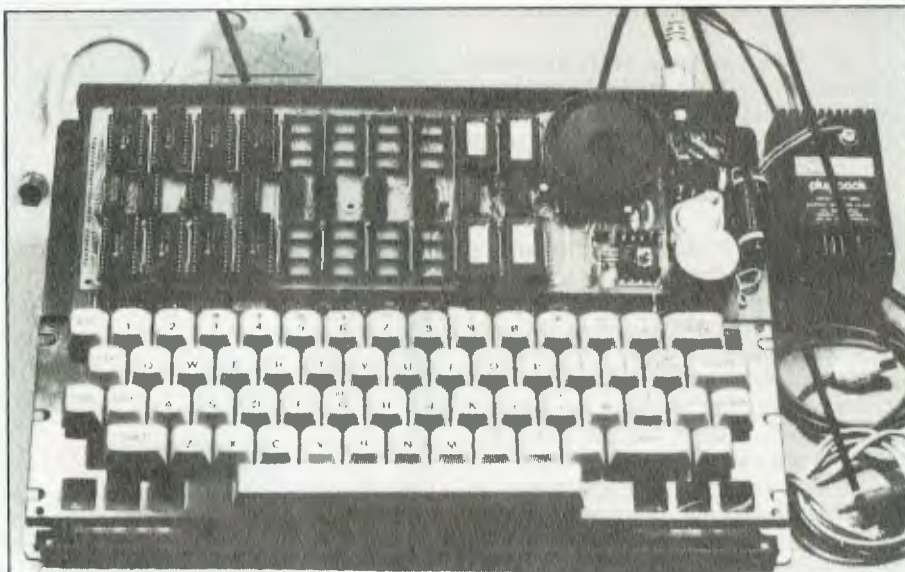

MY BEE was one of the first few out of the hive, being in kit form with the old-style case and single voltage regulator. Like most owner-builders I had my share of troubles and blunders, but as time passed several problems grew into monsters that in reality were basic in nature, but were not obvious until various stages of frustration and desperation had passed. Perhaps I can describe them so that other Bee-keepers may benefit.

Early in my Bee's lifetime there developed an increasing appearance of 'option not fitted' messages. It could appear at any time, even when the Bee was not flying, but an added trouble was that it couldn't fly until one end of the unit was lifted and then dropped. (Thump's Law!) It seemed to me that the most obvious culprit would be a dry joint, or more ominously a crook socket. In support

of this diagnosis was the fact that if the circuit boards were twisted or stressed in some way, a mixture of error messages would be displayed.

A careful check of both boards revealed a few fractured joints on the core board, created during assembly. This type of fault is fairly common and is caused by snipping off the tails of resistors and capacitors after soldering. At the moment of the wire being cut, a sharp pressure is applied to the soldered joint causing the tail to be pushed through the solder, thus fracturing the joint. The secret here is to snip the tails off before soldering. However, resoldering these fractured joints did not cure my problems.

So, with much apprehension I embarked on a program of replacing all the sockets, first on the motherboard. I made a wooden structure to support the board on its edge, but with both sides accessible, so that by applying

a hot, specially made Scope iron bit to the terminals along one side of a socket, I was able to reef that side out of the board. A similar application of the iron to the other side of the socket, and presto – it was all out in about twenty seconds. Then with a solder sucker on one side and an Adcola iron on the other side of the board, each hole in turn was sucked empty. The IC was then withdrawn from its socket and inserted directly into the board. Soldering meant it was in for keeps.

After removal of all the sockets (except those of EPROMS and the 40-pin ICs), I thought there was no way the faults could not have been cured. But there was still no change in the Bee's condition. So, the core board got the same treatment. Again no change: the old problems were still there.

## On Close Examination

Examining the core board several times with a 10x eyeglass showed no shorts or broken tracks. But ... what were those black marks on the connecting pins? I could see a fine black line along each pin made by contact with the socket contact. I certainly would expect to see a shiny mark ... but not black! Hard rubbing with my finger gradually removed it, and then came a slow dawning. Grime! Many removals and replacements of the core board had caused an accumulation of particles on the pins. Because of the low operation voltage, the dirt was causing intermittent open and/or high resistant circuits.

A quick run out to the workshop to get a can of CRC2-26; a short spray of oil into a teaspoon; a dipping of the finger and smearing of a light film

onto the pin contact faces; the replacement of the board, and what luxury – the Bee flew with renewed vigour and vitality.

Eventually, another trouble showed itself: rather than the 'Option not Fitted' error the machine would give all sorts of error messages. Pressure on the core board in the area of C22 seemed to bring it on, so out it came again for close scrutiny. With the thought that plated-through holes could be a trouble source, I had a closer look at them. Here I noticed one plated-through hole with the printed circuit that should surround the hole *in* the hole. Aha, I thought, I've found it.

With soldering iron in one hand and solder, wire and cutters in the other, the hole was suitably bridged. On replugging the core board back into the Bee and switching on ... nothing had happened. What had gone wrong? Careful examination with the eyeglass showed a perfect job. I

refitted the board to the Bee, but still no go.

### Light Dawns

Several cups of coffee later it came to me, through the mist of confusion, that the hole seemed to be a little larger than others. Perhaps the hole had been drilled out to *remove* the plating, but a copper dag remained that was making intermittent contact.

Back to the workshop, get the iron hot again, remove the strap and with a 1/32" drill, countersink the hole on both sides of the board. The Bee flew again. (On the early core boards pin 7 of IC6 was connected to pin 13 of the inter-board connector. To rectify the problem it was convenient to simply drill out a hole in the printed circuit next to C22, thus breaking the circuit. Later core boards have no track from pin 7 of IC26 to the hole.) But had this really been the problem?

It wasn't long before the old troubles showed once more. Again, after much searching and bad language, it emerged that there were tiny spots of compacted grime on the core board and connecting pins that were unaffected by the CRC. (I'm not too sure what happened, but probably the grime was dissolved by the first application of the CRC, and then settled again into little spots.) However, removal with a very fine abrasive cloth (I used jeweller's rouge paper) and another treatment with CRC returned the Bee to complete reliability.

Since then the Bee has been flying well, darting from program to program, pollinating all the variables, and with no stings at all.

So, to all you apiarists, if you've had any problems such as I've had, a little dose of CRC2-26 (WD40 and others should also be OK) may be the answer. □

## SIMPLY BEAUTIFUL



### THE CONCEPT, THE SYSTEM, THE FLEXIBILITY

#### The Concept

The Sierra Multi-Processor computer systems by Microtrix were designed to provide users with the fastest, most flexible multi-user systems available. Up to 16 users can be attached to the system, each user having his own processor card, memory, and input/output ports. To obtain the maximum performance from our hardware, we chose the advanced TurboDOS operating system. Networking TurboDOS provides more powerful and expanded features than either CP/M or MP/M while still remaining file compatible. Performance rivals mini-computers.

#### The System

The Sierra multi-user system is available in several forms. The desk top version shown can be configured with either two 8" floppy drives or one 8" floppy drive and a hard disk. Up to five users can be supported. Other versions can maintain up to 16 users. Hard disks are available in various sizes.

#### The Flexibility

The built-in flexibility means a user can buy a system tailored to his requirements now, and then upgrade as circumstances require. Contact us now for further information on a configuration to suit your requirements. You'll be pleasantly surprised at how much computing power your money can buy.

## The Sierra Multi-Processor: Simply Beautiful



MICROTRIX PTY. LTD.  
24 Bridge St.  
ELTHAM, VIC. 3095  
Phone: (03) 439 5155  
Postal: PO Box 158  
HURSTBRIDGE VIC., 3099.

Dealer Enquiries Welcome

# PACESETTER

## Professionals in Peripherals.

Pacesetter Peripherals, Australia-wide distributors of the most reputable international brands at highly competitive prices. A wide range of models is available to suit most computer systems.



### SILVER-REED DAISY WHEEL PRINTERS

- \* Complete Range
- \* Bi-directional
- \* Logic Seeking
- \* Bold Face — Superscript-Subscript
- \* Parallel/Serial Interface
- \* 17-40 CPS
- \* 13-17" Paper Widths

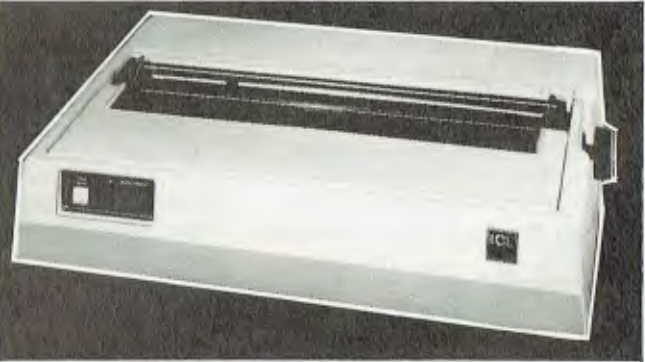

### MICROLINE DOT MATRIX PRINTERS

- \* Proportional Spacing
- \* Bi-directional
- \* Logic Seeking
- \* Full 96 Character Set
- \* 80-136 Column Widths
- \* Dual Interfaces
- \* Speeds up to 350 CPS

### PACESETTER P17 TERMINALS

- \* Full screen attributes
- \* 128 displayable characters
- \* Detachable typewriter style keyboard
- \* Screen format of 25 lines by 80 characters
- \* Full range of foreign language character sets available

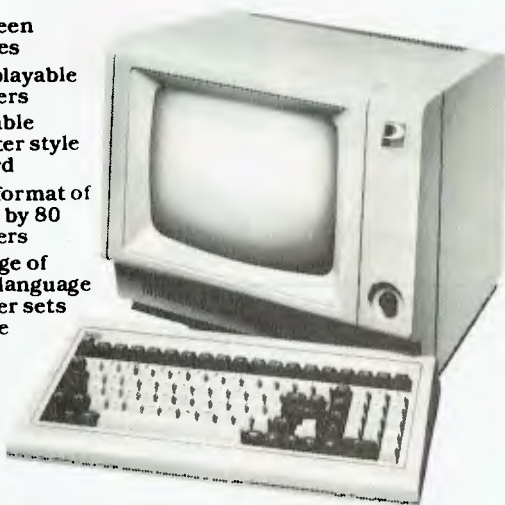

### TEXAS INSTRUMENT DOT MATRIX PRINTERS

- \* 80-136 Column widths
- \* 150 CPS minimum
- \* Parallel and serial communications Interfaces
- \* Standard ASC II character set
- \* Seven alternate European character sets
- \* Mosaic graphics character set
- \* Compressed, bold and expanded print

FOR FURTHER INFORMATION CONTACT:



## PACESETTER PERIPHERALS

A division of VSI Electronics (Australia) Pty. Ltd. (Incorporated in S.A.)

16 Dickson Avenue, ARTARMON 2064. N.S.W. PHONE: (02) 439 4655

Adelaide (08) 267 4848 Brisbane (07) 229 8827 Melbourne (03) 818 0688 Perth (09) 328 8499

June 1984

# your BUSINESS computer

MAGAZINE

**PORTABLES  
BRINGING  
BUSINESS  
HOME**

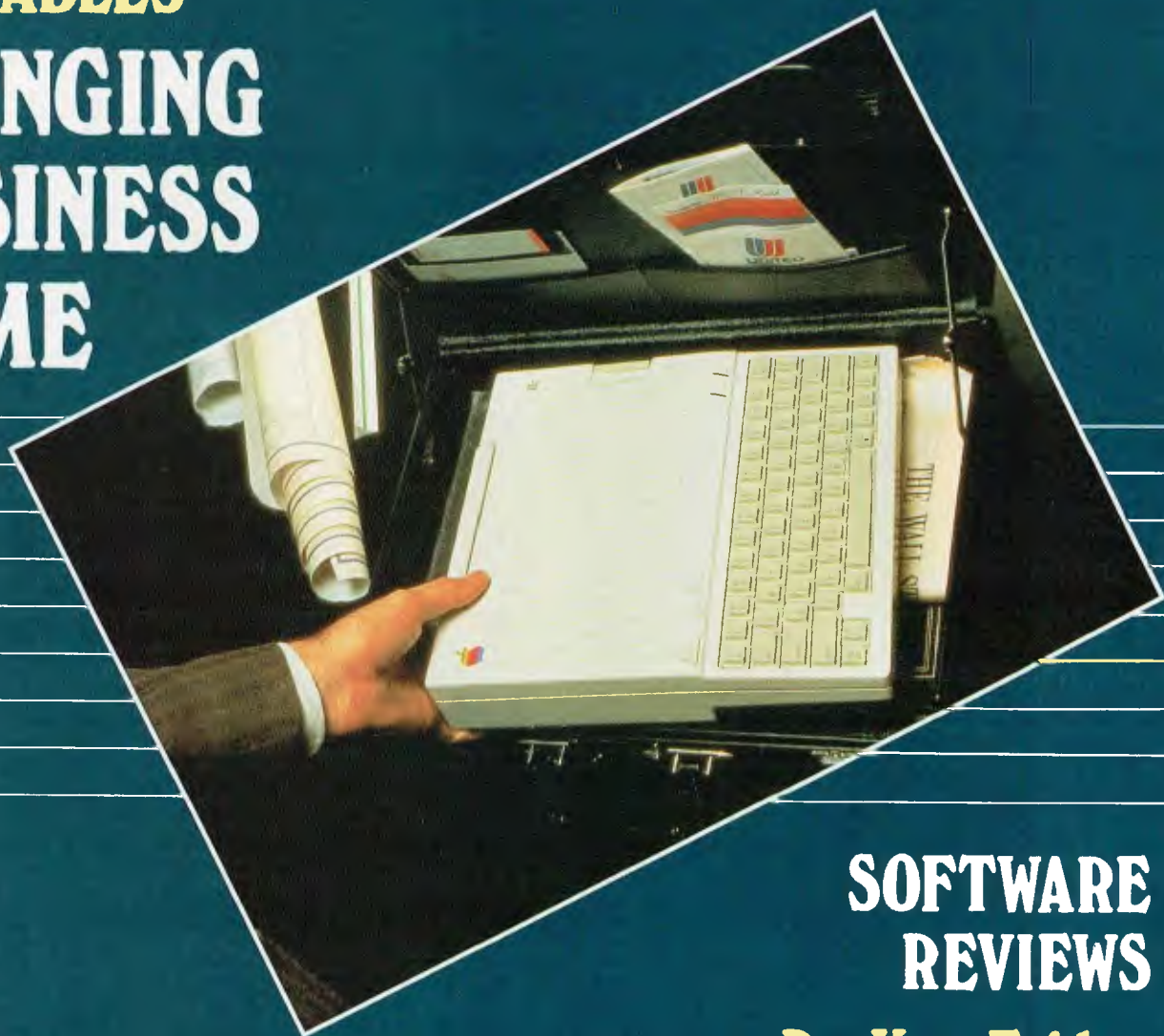

**SOFTWARE  
REVIEWS**

**ProKey, Friday**

**Unusual Business Applications**

# Talk to the world!



DIGICARD offers you a truly versatile Communications Card for APPLE //e, allowing you to "TALK" to mainframes, mini or micro computers by telephone or direct wire communication. It also allows you to print data direct from your screen. Whether you are a stockbroker, an educator or a scientist, the DIGICARD COMMUNICATIONS CARD offers you easy access to your data bank.

For further details contact your Apple dealer or DIGICARD direct on (03) 439 1366.



**MacLagan  
Wright & Associates**

INNOVATIVE  
ELECTRONICS

PTY LTD  
Incl. in Victoria

11/22 Bridge St,  
Eltham, Vic. 3095,  
Australia.  
Phone (03) 439 1366



**Managing Editor**

Jamieson Rowe

**Editor**

Jane Mackenzie

**Art Director**

Ali White

**Art Production**

Vicki Jones, Brian Jones,  
Toni Henson

**National Advertising Manager**

David McDowall

**Victorian Sales Manager**

Mel Godfrey

**Contributors**

Les Bell, Norman Kemp, Evan McHugh, John Nicholls

**ProKey Review**

4

*If you've ever wanted to alter the configuration of your IBM-PC's keyboard to suit different programs — or just your own whim — ProKey is the program for you. John Nicholls wouldn't use his computer without it.*

BY JOHN NICHOLLS

**Portable Computers — Bringing Business Home**

7

*More and more manufacturers are starting to produce truly portable computers with all the facilities and capacity of a desktop model. Will this close the gap between home and office computing?*

BY NORMAN KEMP

**Making Buildings Intelligent**

11

*The Building Intelligence System allows control and monitoring of a building's environmental control processes and security that can save a third of a company's power bills a year — and it runs on a microcomputer system that can be set up for as little as \$10,000.*

BY EVAN MCHUGH

**Friday!**

14

*"Get all your work finished by Friday!" run the ads. Les Bell examined this list management program on a jaded Monday morning, but was nonetheless fairly impressed.*

BY LES BELL

**Better Service by Computer**

20

*Using a computer to run customer service facilities and a workshop is a less usual application than simple accounting or word processing work, but that's how Haden Engineering has streamlined its operations.*

BY NORMAN KEMP

**Put on your Dancing Shoes**

23

*When Paul Wright left ballet dancing and started in business as a specialist ballet shoe manufacturer, it was the start of a company which recently won the prestigious National Small Business Award — and a computer helped him to achieve this success.*

BY NORMAN KEMP

**Tom Thumb vs. the Goliaths**

29

*A chain of twenty shops with a variety of lines plus volume supply of goods to large organisations would be expected to computerise using a pretty powerful computer. When Sirrah Meats applied a computer to its operations, however, it began almost by accident with a Dick Smith System 80 — which is still controlling the firm's business today.*

BY NORMAN KEMP

*Your Business Computer* is published bi-monthly as a pull-out section of *Your Computer* magazine by the Federal Publishing Company Pty Ltd, 140 Joynton Avenue, Waterloo 2017. (02) 663-9999. Telex: FEDPUB AA74488. Publisher: Michael Hannan. Printed by ESN — The Litho Centre, Sydney. Typeset by Hughes Phototype, Spit Junction NSW. (02) 960-2788. Distributed nationally by Gardon and Gotch.

Editorial contributions: Contributions to *Your Business Computer* are welcome and will be given every consideration. Although the greatest care will be exercised with contributions, no responsibility can be accepted for the safety or return of any letters, manuscripts, photographs or other materials supplied to *Your Business Computer*. All contributions should include your name, address and home and office telephone numbers. See *Your Computer* 'Services' page for more details on contributions, style, etc.

*If you've always wanted to tell your IBM-PC's keys what to do, instead of having to live with program-defined functions, ProKey allows you to tamper at will. John Nicholls finds this utility indispensable.*

# ProKey

**P**rokey is a program that grows on you very quickly; having used it once you'll wonder how you ever did without it. It is written for the IBM-PC and some of the PC's compatible cousins.

What is ProKey? It is usually described as a keyboard enhancer, but this is not an adequate description of its capabilities. Another way of describing it is as a macro processor, a term that calls for some explanation. A macro is a single keystroke that stands for a whole series of keystrokes. Hence, a macro processor is a program that translates the single keystroke back into the sequence previously recorded. ProKey is produced by Rosesoft, whose president is Eileen Rose. I prefer her description of ProKey: she calls it a software enhancer.

## Enhancing the Keyboard

Let's take each of these definitions and see what ProKey can do. The first was a keyboard enhancer. For a touch typist, one of the strange features of the IBM-PC keyboard is the left shift key, which has been moved one place to the left of its usual position to accommodate a backslash key (\). With ProKey it is a simple matter to reverse these two keys. Some programs give different meanings to such keys as the backspace, delete and insert keys. To achieve consistency among your different programs, you may wish to change these meanings. The new version of ProKey (3.0) also provides several alternative keyboard layouts, including three Dvorak Simplified Keyboard layouts.

There are a number of programs which allow you to record series of keystrokes and recall them with one or two keystrokes. Thus, you can enter printer

set-up strings, command sequences, or commonly used names or phrases. For example, because the word ProKey is used frequently in this article, and because it is awkward to type with the capital in the middle of it, I have temporarily allocated this word to a macro to save typing it again and again.

As a macro processor, ProKey has a range of features which most of its competitors are lacking. To start with, nearly all the keys – including all the shift states – can have macros assigned to them. There are four shift states: unshifted, CAPS-shifted, CTRL-shifted and ALT-shifted. Some people may not realise the ten function keys also have the same shift states, so the keyboard has forty function keys, all of which can have strings allocated to them. About the only key combinations you need to avoid are those which DOS uses for synonyms; such as Ctrl-m which is the same as return, and those like 'esc' where it would be difficult to operate a program if the original key definition were not available. Full details of those keys to avoid (and why) are given in the ProKey manual.

## Macros Are Easy

Entering macros is a simple procedure, with two alternatives available. In the first method, you record the keystrokes as you are using your program. You type <alt=> followed by the key you want to use to recall the macro, and from that point every keystroke you make will be recorded until you press <alt-> to finish recording. What could be simpler than that? The keystrokes you enter are in a standard ASCII format; so you can edit the files with a word processor or with EDLIN, the editor supplied with DOS. This is the second method of re-

coding macros and is also a very useful way of editing macros.

You can enter pretty well anything you like in a macro: ordinary keys, function keys, special keys like <center>, <PgDn> and <Esc>. You can also make the program pause for operator input, either for a fixed number of keystrokes or for a variable-length string. You can also use nested definitions or use one macro to recall another one.

The defaults incorporated in ProKey allow you to use 4000 bytes of RAM (4K) for macros. An individual macro can have up to one quarter of the total, so the default maximum is 1K (about one page of text). You can extend the default maximum from 4K to up to 50K, giving you a maximum for one macro of 12.5K (about three typewritten pages)! The ProKey program stays in memory all the time, so you need 7K for this both in memory and on every diskette on which you have recorded ProKey strings. This amounts to only about two per cent of a diskette's capacity and is a small price to pay for the convenience. As a matter of course I add ProKey to all my data diskettes, because I know I'm always going to find some use for it.

## Sets for Starters

The makers of ProKey have provided what they call 'Starter Sets'. These are files of macros that have been written for some of the most popular programs: WordStar, Visicalc, Lotus 1-2-3, and dBase II. They can be used as is, or can serve as sources for ideas. I'll give just one example. In Lotus 1-2-3, entering lots of figures becomes tedious because the IBM keyboard does not have cursor control keys separate from the numeric keypad. ProKey suggests redefining the

four bottom function keys – F7, F8, F9 and F10 – as cursor keys. I have found this most useful, since you can use the numeric keypad with your right hand while you move the cursor with your left. You might then ask, what about the original Lotus use of these function keys? ProKey's answer is that if you press the single back quote (`) immediately before a key, that key will revert to its original definition. I felt this would add to the difficulty of operation; having six function keys with original definitions and the others requiring you to press another key first. So, I redefined all the Lotus function keys so that the original definitions are all available in the shifted state. All an inexperienced operator then has to remember is to use the shift to get Lotus's definition.

### On the Soft Side

So much for macro processors. Now we come to one of ProKey's most interesting uses: as a software enhancer. In today's software market, several trends for integrating software are apparent. One is to produce a single program which will handle multiple applications (like in Context MBA, Lotus 1-2-3 and Lotus Symphony). Another is to provide an environment which allows different programs to be handled in the same manner (VisiOn and Microsoft Windows).

It is in this last approach where ProKey shines. You can standardise commands among programs so the same key always performs the same function (backspace deletes the character to the left of the cursor); you can automate routine tasks (setting defaults for a word processor or print formats for a spreadsheet); or you can tailor a program so no special knowledge is necessary to run it. If you have a hard disk, you can set up a menu listing all possible applications and what key combinations will access each one. If you don't have a hard disk you can set up the applications so each one can be run by inserting the appropriate disk and pressing the same key. By combining ProKey with batch files you can have the computer start up, load your macros and start executing them. In Lotus 1-2-3, one of our macros takes the operator straight through the access menu to the worksheet and prompts for the name of the file to be retrieved. In

another, where the PC is configured to emulate a terminal on a mainframe computer, the only thing the operator needs to do is insert the diskette and switch on; the batch file and ProKey provide all the emulation codes and the log-on codes.

### Waiting for the Program

In some of these operations ProKey may go too quickly for the program, so it has provisions either for slowing it down or for incorporating delays – from a tenth of a second up to hours – in the program. Visicalc and Supercalc are two programs which need the slower operating speed.

A number of ProKey's defaults can be changed. Handicapped people will be interested in one which lets you enter keys one after the other, rather than simultaneously. Thus you can deal with such combinations as <Ctrl><F4> and <Ctrl><Alt><Del>.

ProKey 3.0 is copy-protected, though you can make application to RoseSoft to provide you with a copyable version. Should you acquire the copyable version, you will find the copyright notices at the beginning of the program list both your name and the serial number of your computer, as a final attempt to discourage unauthorised copying.

### Prerequisites

To run ProKey you'll need a disk drive. If you want to run it in conjunction with Wordstar you'll need 96K of memory, and 64K of memory is usually required if you want to use it with any other packages. Your system should also be using any version of DOS.

### Minuses

At this point, you may be wondering whether ProKey has any faults. An occasional oddity has cropped up, such as a prompt appearing on a colour monitor while I was using the monochrome monitor. But the only real problems I have encountered with the program are with having two programs in memory with conflicting key assignments. This can lead to weird results, but the solution is simple: clear all ProKey's key assignments when switching programs.

The documentation is the only component I can fault. It has been completely rewritten from Version 2.1 and is a vast improvement on the earlier version, but it still has some flaws. The index is not

particularly useful and you can find what you want more quickly by running through the table of contents, which is quite detailed. There are two areas where I became confused. First, you start recording interactively by pressing <alt=>, but in edit mode you start by typing <begdef>. This is stated in the manual, but I missed it. Then I had trouble getting a string of macros properly saved on a disk. The sequence of commands required to do this is straightforward enough once you understand the process, but nowhere is it set out in detail. For the record, if you are modifying a file with EDLIN, you SAVE it to disk, CLEAR all macros from memory, READ your new macro into memory, then WRITE it to disk. You can then READ it back into memory (overwriting any existing files) or MERGE it into memory with existing files. Other than that the documentation is good, with a list of error messages and what to do to fix them, a full list of all possible macro names, a glossary, and a list of the few programs that are incompatible with ProKey.

If you are a newcomer to computing the advantages of ProKey may not be immediately apparent, but after a few months this will change; and like me, you may find it indispensable.

The local distributor of ProKey is Sourceware, who tells us that Version 3.0 sells for \$169. You may be able to get a better price than this if you shop around, but whatever the cost, it's worth it! □



# People who need People

16-bit Microcomputer by Olympia 



If you have been searching for a true 16-bit Microcomputer to run CP/M86 and MS/DOS or even MP/M86 then consider these features:

- Main Memory 128K to 512K.
- Dual Floppy Diskette Drives  
1.3 MB Storage.
- Intel 8086 Microprocessor  
and 16-bit Databus.
- High Resolution Graphics:  
640 x 475 Pixels.
- Optional 10 MB Integrated Hard Disk.

Check off which applications you require:

- |  |   |
|--|---|
| <input type="checkbox"/> Word Processing | <input type="checkbox"/> Accounting Packages  |
| <input type="checkbox"/> Spreadsheet     | <input type="checkbox"/> Specialised Software |
| <input type="checkbox"/> Data Base       | <input type="checkbox"/> Games                |
| <input type="checkbox"/> Office Systems  |   |
| <input type="checkbox"/> Typing Tutor    |   |



 **People**  
16-bit Microcomputer by Olympia

For a free brochure on the Olympia 'People', please send to Olympia (Aust.) Pty. Ltd. PO Box 152, Artarmon, NSW 2064.

Name .....

Address .....

..... P/C.....

Company ..... Tel.....

OLY9500

Trademarks: CP/M86 and MP/M86 — Digital Research. MS/DOS — Microsoft.

 **Olympia International**  
INFORMATION AND COMMUNICATION SYSTEMS

Sydney (02) 439 3444  
Melbourne (03) 329 9455

*The barriers between home and office computing are gradually being demolished as the introduction of full-capability portable computers makes computer power transportable, and by the end of 1984 it may be difficult to identify the distinctions between them.*

# BRINGING BUSINESS HOME

BY NORMAN KEMP



Since IBM announced the PCjr and the portable Personal Computer – neither yet available in Australia – price alone has ceased to be the criterion by which personal computers can be judged. Home computers were once thought of as costing under \$500 and were mainly for playing games. Business computers started at over \$1500, although about \$6000 was needed to buy a full configuration with disk drives and printer.

Manufacturers are now closing the gap, so that the home computer, except at the very lowest levels, can be a pint-sized version of the office desktop workstation without losing any of the power. Each will have compatible disk drives and a common operating system able to run a complex spreadsheet program such as Lotus 1-2-3, or the same word processing or graphics programs on either of the machines.

Probably very few business people in Australia have wholly accepted the American executive's willingness to cheerfully hump a computer around and forgo their leisure hours in an extension of their everyday office tasks. However, as portable computers are gradually gaining the power of their bigger brothers, even the unwilling Australian may feel obliged to keep up with the convergence of home and business computing.

The man who foresaw the possibility of this happening was Dr Adam Osborne, a British-born and educated engineer who, between publishing computer books and devising software programs in the US, concluded about four years ago that the world was ready for the takeaway computer.

It was his first machine, the Osborne 1, that started a so-called 'portable' trend which has now reached revolutionary proportions. He is not now with the

company still bearing his name, or associated with the latest developments of the Osborne, which will culminate soon in an IBM-compatible model, but his originally novel idea of a computer which could be stowed theoretically under the passenger seat of an airliner has been copied and vastly improved by a score of manufacturers.

Portable was a generous word to use for this pioneer machine, as it weighed around a hefty 15 kg – as do several similar machines today which are in the same style. But true portability is now available with computers weighing a third of the Osborne, though a proportion of those at the low end are still in early stages of development.

## Takeaway Computers

The takeaway computers that are on the threshold of being either home or office machines fall into four broad categories. ▷

# BRINGING BUSINESS HOME

First is the by now traditional portable for the macho man, weighing between 10 and 15 kg, and distinguished by being contained in a heavy metal case – though some brands are experimenting with heavy-duty plastics – having a clipover keyboard with a handle on the reverse side, usually twin disk drives or one floppy and one hard disk, screens generally 7 in (17.8 cm) or 9 in (22.9 cm) and ports for a printer and a telephone modem. Osborne, Kaypro, Corona, Eagle, Otrona, Compaq, Hyperion and Chameleon are typical of those marketed in Australia.

This is a conventional design, which even IBM has adopted. As most can be used either as desktop machines or trans-portables which can be moved to outside locations, this design will probably last at least another couple of years.

The second type is a wider interpretation of the portable concept, such as the Apricot, which could set a new style with the processor separate from the monitor and detachable keyboard. This design enables the computer processor to be packed into a bag for carrying; the computer is unpacked and plugged into another display screen – but not a television set – at its destination, or makes use of its inbuilt LCD microscreen, which can display up to 80 characters.

The third type of portable is being described as the 'briefcase' variety. First seen from a Japanese manufacturer in mid-1983, it has the usual keyboard features and may have a built-in printer, but the screen is a monochrome liquid crystal display of 40 or 60 characters across and from five to 16 lines deep, which in some versions folds over when not in use. An Australian model, the Dulmont Magnum, was close to being a pioneer of this variety, represented also by the Japanese Sharp PC-5000 and US-made Gavilan.

The fourth kind is a close relative, the 'lap' computer, represented by the Tandy Model 100, NEC 8201A or Olivetti M10 and soon to be produced for other manufacturers. (See *Your Computer*, April 1984, 'Personal Computer of the Year' articles, for an evaluation of these 'lap' computers, and the Sharp PC-5000, Hyperion and Dulmont Magnum mentioned earlier.)

The lap and briefcase styles will probably eventually merge, with the best features of each being retained in a single-sized computer. These features will

probably include memories of at least 256K, a 24-line, 80-character display (probably liquid crystal), IBM-PC compatibility, ergonomic keyboards and, most important for a portable, a weight of one to 10 kg. They should sell at prices starting from just below \$1000.

Portables are not the only computers that can be carried around – the desktop-style IBM PCjr and Apple Macintosh are both light enough and designed to withstand a certain amount of physical relocation from time to time. Not content with this, however, Apple has just released a true portable, the Apple IIc, which is compatible with the Apple II and IIe lines and runs all that swag of Apple II software (see *Your Computer*, May '84, for more details). This should give Apple quite an edge with all those small business people to whom computerisation equals an Apple II, as it provides the capability of transporting work between home and office without losing any facilities or ending up with a hernia from heaving all that equipment about.

## Off-The-Shelf Computers

The true portables of the next few years will have the more convenient facilities built into them, as well as being cheap. They will be specially manufactured to be bought off the shelf, taken to work, put in a car and brought home, or be set up at a conference or different workplace. All have the same objective – to move processing power from a fixed position on a desk to any point the user requires, without interruption to the job.

The significant factor is that they will all run the full range of business software applications from compatible larger machines – though not necessarily the same software as each other – and will have communications to fit into distributed networks around offices or between branches, or to link microcomputers with central mainframe databases from which information can be obtained for storing on individually-owned disks for working on in the real sense of personal computing.

Taking a day off from commuting to the office may soon become an accepted part of the information society, when a phone call and a practical portable computer will remove the barriers between home and office communications, and still allow a person to achieve a full measure of productivity. □





Far left, top to bottom: Bytec Hyperion, Osborne I, Tandy Model 100.

Bottom left: Apple's new IIc.

Left and below: The Apricot, with a close-up of its microscreen.

Bottom: Sharp PC-5000 with built-in LCD and thermal inkjet printer.



# Nissei Sangyo

**One of the world's largest system marketing and sales organisations!**

It's not so important that you know our name. Although, Internationally, we are well-known marketing and sales specialists of electronic products — and a turnover of more than A\$1,400 million speaks for itself. However, it is much more important for us that you are impressed by our products.

## **VERSATILE, LOW COST WP-1000 PRINTER**

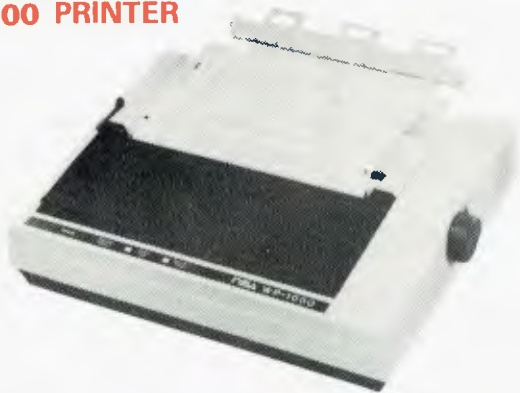

### **Specifications:**

- 9 Wire, 100 CPS (10 CPI) Logic Seeking and Incremental Operation, 80 Column Printer
- RS232C and Centronics Interface Standard
- Backward Feeding Standard
- Fanfold, Roll Paper and Cut Sheet Paper is usable as standard
- Characters of various size are available  
Condensed, Double-width Pica and Elite etc.

## **A PICTURE'S WORTH: NSA/TOEI COLOUR MONITOR FTC-1201-R**



### **Specifications:**

- COMPATIBLE WITH IBM PC AND OTHER FINE PERSONAL COMPUTER
- 12", 640 x 200 LINE RESOLUTION
- RGB ANALOG/RGB PLUS INTENSITY TTL LEVEL/RGB TTL LEVEL..... SWITCH SELECTABLE COMPOSITE OR SEPARATE TTL LEVEL
- QUALITY CONSTRUCTION, MADE IN JAPAN

Dealer enquiries welcome.  
For further information, please contact:

**Nissei Sangyo Co., Ltd.**

(Incorporated in Japan)

200 PACIFIC HIGHWAY., CROWS NEST,  
N.S.W. 2065. AUSTRALIA.

TELEPHONE: (02) 923-1522 (4 lines)

TELEX: AA70941

FACSIMILE: (02) 922-2498



*Imagine a machine that is so efficient it can heat a 20-storey building for less than the cost of heating the average family home. Not only that, it can protect the same building from intruders, operate lights so that they switch off 15 minutes after the last person leaves a room, and can provide detailed reports on each area it controls. Stop imagining, because such a machine exists.*

BY EVAN McHUGH

# Making Buildings Intelligent

**O**n the whole, most computer interviews don't take place in basements. That skulking Woodward and Bernstein (*a la* Watergate) type of venue is pretty much the domain of the gutter press and certain TV documentary programs. But sure enough, the interview for this article was in the basement of the HCF building in George Street, Sydney. Actually, as basements go, this one is quite swish – not so much a basement as a nerve centre, including a theatrette and a suite of offices.

Henry Blanter, who markets and supports the Building Intelligence System and the Homebrain, has his office in this basement. In terms of the usual office, this one must be just about one of a kind. The whole back wall is the very latest in high tech, with three television screens constantly monitoring activity in key locations around the building, and two computers are installed in the room. There is also a box with flashing lights mounted on one wall, and a huge control panel behind you as you talk to Henry. Not my impression of a basement at all – no rats, puddles of ooze, or the dank smell of decaying rubbish. Instead there was a carpet of soft reddish pink with quite a deep pile!

The overall impression was that I was in the basement of the future. And indeed I was. The technology employed in Henry's office represents the sort of management techniques predicted for the 1980s but in fact installed in very few areas.

## Background

It wasn't until the energy crisis of the Seventies that people began to look at the way buildings use energy and how that use could be more efficiently managed. The usual approach was to install a system to provide both heating and cooling, and you just switched to whatever was required at any particular time. This meant that in the middle of summer the boilers had to be running all day just in case it turned cold, with the same happening in winter with the coolers.

Another approach to cooling took air from outside the building, chilled it to very cold temperatures, then pumped it around the building. Once in the system

in this way, it was reheated and pumped into the working environment to maintain the required temperature. For example, if it was 24 degrees outside and you wanted it to be 22 degrees inside, the air would probably first be cooled to zero and then reheated to 20 degrees to produce the desired result.

All these systems were quite obviously wasteful of energy, and clearly a new system that could use the existing conditions as a basis for producing the desired conditions – rather than creating the required temperatures from external sources – would be able to produce considerable savings. If it is a hot day you want to be able to switch off some, or



Henry Blanter in his high-tech office/control room in the basement of the HCF Building, Sydney.

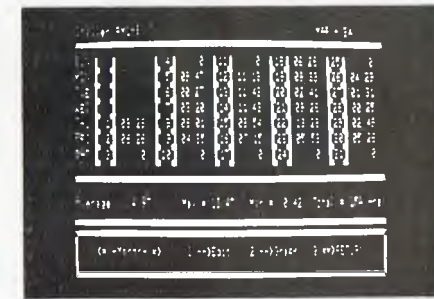
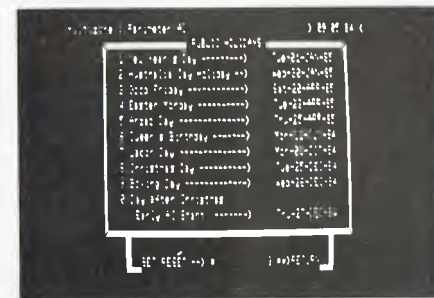
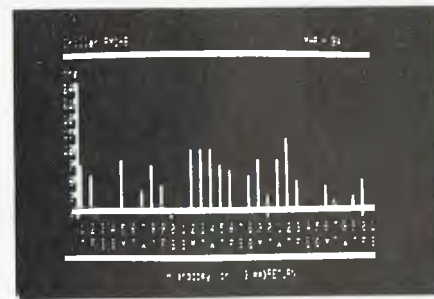
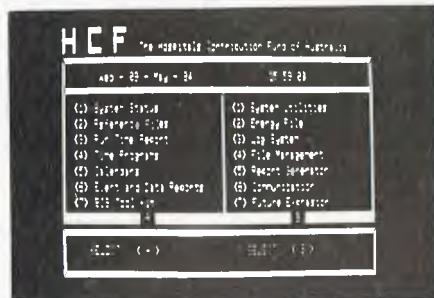
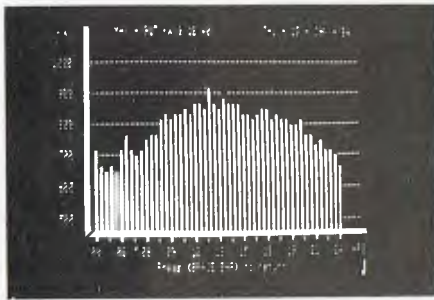

Some examples of data available on building management and control on the Building Intelligence System.

even all, of the boilers; if it is cold you don't want to run the chillers. Ideally, if it is cold outside but the air in the building has become too hot, you want to be able to use the cold outside air to do your cooling; a system that could open the vents and blow the cooler air from outside round the building would be ideal.

### Building Intelligence

Systems that operate in this way have been around for some time; IBM, Honeywell and others have brought out systems that contribute significantly to energy management programs. However, none match the cost effectiveness and comprehensiveness of the Building Intelligence System.

This system is programmable and can be linked to a large range of microcomputers to allow reprogramming, report production and system monitoring. The system will operate the environmental facilities and lighting, and will keep a security check on the building.

It is built around a 6502 microprocessor, has 64-Kbytes of RAM, and is battery-backed to allow for power failures. This lets the system continue its monitoring functions for three hours after the failure. After three hours the system goes into sleep mode to save the present system status for the next thirty days.

Essentially the system looks for a set of conditions, and when they are all satisfied it takes some sort of action. For example, if the building is cold and it's early morning, it starts the heating. Another function is to log events in the system, so that reports can be produced on the hours the boilers are operating each day, maximum temperatures each day and so on.

On the technical side, the basic system accepts 32 bi-state inputs, has its own operating system and connects to other microprocessors through a standard RS232 interface. There is also provision for power line carrier, which permits wireless control of the energy systems and lighting; no crawling around rewiring the building to install the new system.

### Maintenance

The system can also have facilities provided for the maintenance program, and at the end of each maintenance period a report can be produced, warning of the approaching preventive maintenance call.

This facility is extremely useful, as it takes the difficult task of monitoring all equipment usage off the hands of the site manager and provides him with a simple readout of the present situation and any necessary checks. The reduction in paperwork and manual calculation is considerable.

### What you need

A typical system configuration for, say, a 15 storey building might be: one Building Intelligence System, a printer and a TRS-80. The microcomputer would be used to program the BIS and store utilities for the formatting of the various reports produced by the system. Such a system could be fully installed for about \$10,000.

The average building that spends, say, \$10,000 per month on energy would recover the cost of the system within 12-18 months. Some businesses have managed to recover the cost within four months. The extent of savings that can be made are phenomenal; the HCF building cut its fuel bill from 250,000 litres to 30,000 litres per annum. For a building of only 13 storeys which has an energy bill of \$1 million per annum that represents an incredible dollar saving.

The use of a microcomputer is another advantage. It is only needed by the Building Intelligence System about once a day under normal circumstances, so the rest of the time it can be used to do something else, such as word processing, calculation and so on. Another feature is that you can call up the system on the phone to check its operation and reprogram it; this can also be used to check on the security of the building.

### Flexibility

One of the advantages of the system is its flexibility. This allows the manager to experiment with his air conditioning/heating to discover more efficient techniques for controlling the environment. For example, he may wish to make use of the surge of heating caused by a lot of people coming into a building.

Each person represents 100 watts of heating and every light they switch on represents 400 watts. Therefore, why heat the building to the desired temperature before they arrive? Why not heat it to just below that temperature and let the extra heat of the people heat the building up the rest of the way?

There is also a lot of inertia in the heat of a building. This means it may not be necessary to continue air conditioning/heating a building after 4.30 pm, or even earlier on some days. It could be, though, that on a very cold day, for example, the heating will have to kick in again; the BIS can handle this without difficulty.

What's even better is that any of these different strategies can be implemented from the terminal without the building manager or an operator having to fiddle with settings or rewiring on a variety of pieces of equipment. It is all controlled by the software of the computer.

## Marketing

You would think that in a world growing increasingly aware of the issues behind energy conservation, that a product such as the Building Intelligence System would have considerable market potential. The obvious benefits are easily identifiable to potential customers, and yet so far there have been far fewer sales than most people would expect. There appear to be two major reasons why this is so.

The first is to do with computers. Throughout industry, there persists an extraordinary reluctance to use computers even when the benefits are obvious. When Henry Blanter looked at the installation of his system at a Sydney brickworks, he discovered that they could recover the cost of the system in just five days. The energy wastage was staggering. In the face of such wastage one would think a sale was assured. However, it never eventuated, and the reason given was reluctance to use the computer technology; it was an unknown quantity in terms of reliability and usability.

This is even more remarkable in this case, as the system needs little or no operator training, is menu driven and highly user friendly. It has no moving

parts and is fixed to a wall, so has little likelihood of damage or breakdown.

The second reason the system is not as widely installed as you'd expect is its marketing. Currently, Blanter's company is very small and lacks the resources and expertise in marketing to make a significant market impact. Blanter himself is an applications engineer and has still to find the necessary presentation media and style to successfully market his product.

This is a pity, since the quality of the product and the sort of savings it represents are staggering. Every building should have this or a similar system supervising its energy usage as a matter of resource responsibility. The statistics on energy use and wastage in the western world show that energy management is in a disgraceful position; when systems such as this are available for \$10,000 there's really no valid excuse for not using them.

## Actual Savings

*Your Computer* spoke to the maintenance manager of a large commercial premises in Redfern, Sydney, to obtain figures on the savings after installing the Building Intelligence System. Electricity saving per year was \$18,510, and on oil

it was \$13,276. This represented a 12.5 per cent saving on the premises' energy bill.

The maintenance manager also pointed out a number of other savings. Labour costs and maintenance contract costs were both reduced by the ease of use of the system and the availability of data on how the system was performing. He described the system as a "brilliant product", citing its high degree of usability and flexibility as major advantages over its rivals.

## Home use

For the small premises, hobbyist or the home that has everything there is the Homebrain, a little brother of the Building Intelligence System. Selling for around \$1500, this system will randomise the switching on of lights when you are holidaying, will check on open doors and windows and control any other functions that you care to interface with the system.

The contact for the two systems is Henry Blanter. He can be contacted during business hours on (02) 29-1693, or you can write to Remoden Pty Ltd, PO Box Q65, Queen Victoria Building, Sydney 2000. □



# SANYO (FROM \$1495 INC TAX) PERSONAL/HOME COMPUTER. IBM COMPATIBLE



## FEATURES

8088 Processor (16 Bit)  
(Same as IBM/PC)  
MSDOS — (Optional  
CPM86  
128K RAM/Colour  
Single 160K Drive  
with Dual Drive option  
Green Screen Monitor  
(Optional)  
Dual 160K Drives  
(Optional 320K)  
Green Screen Monitor

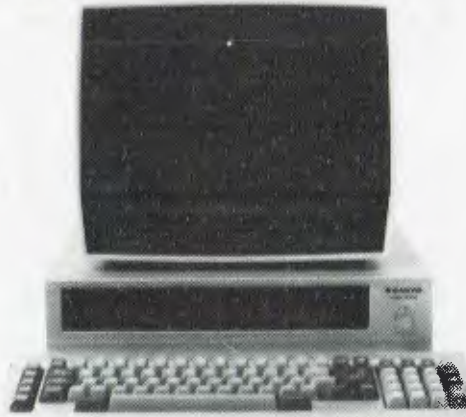

Software Package  
Includes: Wordstar,  
Mailmerge, Spellstar,  
Datastar, Reportstar,  
Supersort

(Normal price \$2600)  
**SPECIAL SOFTWARE PRICE  
\$495**

Melbourne's largest range of programs  
Friendly expert advice and service  
Easy access — plenty of parking

**OPEN SATURDAY MORNINGS**

Established 1968 — Member of O.E.I.A.

# Maxwell

**OFFICE EQUIPMENT (VIC) PTY. LTD.**  
162-164 NICHOLSON ST. ABBOTSFORD  
(near Hoddle Street) Telephone: **419 6811**

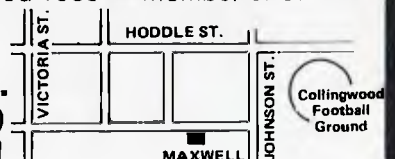

'Get all your work done by Friday!' exclaim the ads for a new list management package from Ashton-Tate. A sceptical Les Bell wrote this review on Monday morning ...

# Friday

**T**he last year has seen a dramatic increase in the number of database management systems on the market. They range from simple list managers to full-blown network database systems, and it can be difficult for the user (who has to use the thing and hasn't got time to read about the latest and greatest) to sort out which is best for him.

One way to decide what's best is to look at it this way. If you are a programmer who wants to set up a moderately complex system, then you will probably be better off with a system such as dBase II, Knowledgeman or Rbase. On the other hand, if you are a non-programmer, you will probably find these systems a bit too complex to understand and use, and would be better off with a program like pfs:file, Visifile or CardBox.

There's a trade-off involved here. The

simple programs, which I tend to describe as list managers, are not programmable and can cope with only simple single-file applications. They run out of steam very quickly when you try to perform tasks like invoicing with them. The more sophisticated programs, on the other hand, can deal with multiple files under program control, and be used to write complete accounting systems—but they require more work to understand.

This is where Friday! comes in. Realising that their dBase II system was too powerful and difficult to use for many people, Ashton-Tate has released this new system, which falls in the list manager category, yet allows upgrading to dBase II at a later stage. While dBase II is complex to use, and has manuals which rank among the worst in the industry, Friday! is extremely simple to use and has excellent documentation.

Friday! is, in fact, written in dBase II

itself. The good news is that this means its data files can be used directly with dBase II (although its index files are different); the bad news is that because dBase II programs run slowly, so does Friday!. It's not as fast as it would have been was it written in some compiled language, but nonetheless it's adequate for many tasks.

The program consists of a number of different files: FRIDAY.COM is a slightly modified version of the dBase II RunTime interpreter, DBRUN.COM, and it's accompanied by its overlay file, DBRUNOVR.COM, and an installation program, SETUP.COM. This is basically the same as the dBase installation program, and so Friday! can be installed on any machine which can run dBase. Versions are available for CP/M-80 (2.2 or 3.0), CP/M-86 and PC-DOS.

The remaining files are SYSTEMF1.SYS, which contains system parameters such as the current datafile, and a number of .CMD files, which contain tokenised dBase II RunTime code.

Installing Friday! is quite simple: one simply types SETUP FRIDAY and then selects the appropriate terminal from the menus. If your terminal is not listed, then it's back to the manuals to find out the terminal control codes, and then a more complex terminal installation procedure.

## Ready for Use

Once installed, Friday! is ready for use. When it first starts up, it asks the user which drive carries the Friday! program and which carries the data. These defaults can be changed as required. It then prompts for the date and displays the main menu. Generally, the display will show a status line at the top of the screen, which tells the user the name of the active file, the name of the menu or screen, the date and a prompt number.

The prompt number is one of the key features which make Friday! so easy to use. Each prompt number is associated with a particular screen or prompt, and directs the user to a section in the manual which provides a full explanation of the options available. These explanations are quite comprehensive, and should get even the most naive user out of difficulties.

The main menu allows the user to enter data, retrieve data, perform other activities or leave the program. Selecting

## SOFTWARE REPORT CARD

Program:	Friday!			
Made by:	Ashton Tate			
Useful for:	File handling, report generation, mailing lists			
Hardware required:	64K minimum memory (8-bit) or 128K (16-bit), dual floppy disk drive with minimum 126K storage space, 80-column screen, 80-column printer			
Ratings:	Excellent	Very good	Good	Poor
Documentation:	•			
Ease of use:	•			
Speed:			•	
Functionality:		•		
Support:		•		
Value for money:		•		
Extras included:	None			
Options:	None			
Price:	\$360 retail price incl. tax			
Review copy from:	Arcom Pacific, 252 Abbotsford Rd, Mayne 4006. (07) 52-3862.			



# UNIVERSE SUPERCOMPUTER

# The Computer to your

Tough baked enamel paintwork and vinyl coated steel for a virtually scratchproof finish  
Heavy Duty power supply supports a full 20 slot S100 configuration.

Provision for extensive expansion and interfacing with peripherals including terminals, printers, modems and electronic telex.

20 slot shielded and terminated S100 bus for maximum expansion capability

(Optional) Unique 'Unserial Terminal' board for ultra high screen speeds rivalling dedicated Wordprocessors.

Super Intelligent Disk, File I/O processor – one of the reasons Universe is fastest in its class.

High speed, high reliability Static Memory CPU card. Options presently available include: 8085/8088 (8MHz), 8086 (10MHz), 80285, 16032, 68000, Z80

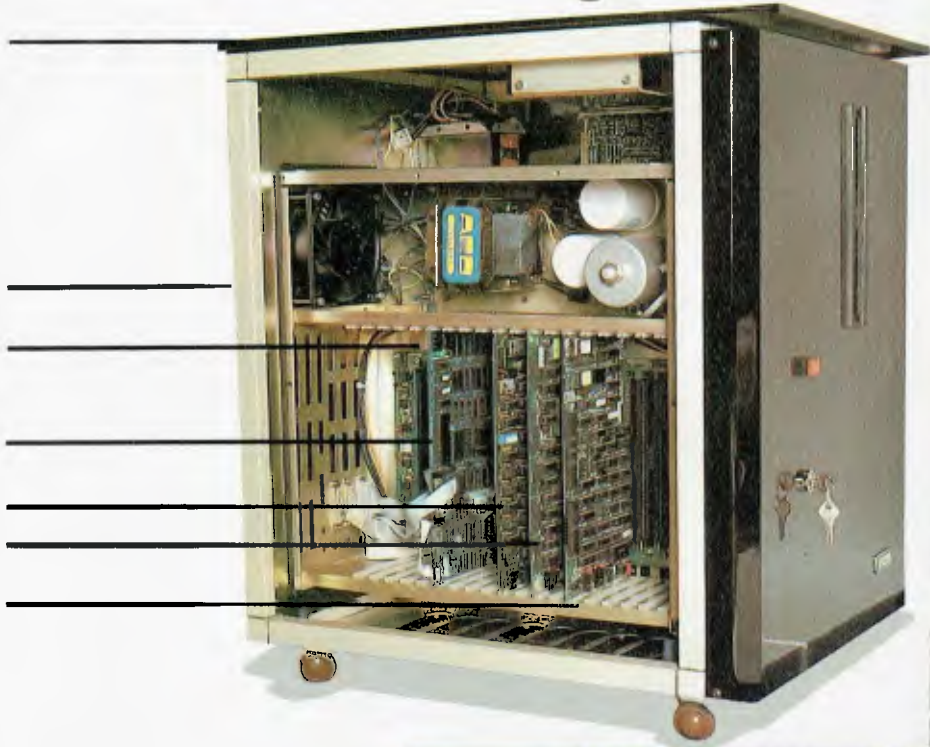

Buying a computer for business can be like walking into a minefield. The computer which is right for you this year may be wrong for you next year. Universe changes this. We designed it to offer you the performance you need now, and cope with your growing needs and with advances in technology. Only Universe can offer you the highest standards of performance – year after year – not just this year. With Universe you buy exactly the right computer for your needs *this* year.

## With Universe you can't make a tactical mistake

Totally modular construction allows any Universe to be upgraded to any other. If you find you have bought less Universe than you need you upgrade. With most computers you are stuck with an unsuitable machine.

## Universe is part of a totally integrated system

The extremely high expansion

capability of our computer means your investment is always secure. You can move from an 8 bit CP/M 80 single user system with floppy discs up to a 25 terminal multiuser 8 and 16 bit system with 200 Megabytes of hard disc and networking to other users. This is all done by *upgrading* your existing hardware and software. There are no traumatic and expensive changovers. Upgrades take minutes, not months. Your data and software are safe at all times.

## Both 8 and 16 bit software compatible. Universe gives total software flexibility

Most computers run either 8 or 16 bit software. Universe runs both *at the same time* in either a single or multiuser installation. Choose either proven (and less expensive) 8 bit software or the new generation of 16 bit software. You only pay for what you need *now*. When you really need 16 bit software, your Universe will run it.



The sculptured keyboard, with long travel contactless keys ensures fast, accurate keying. Special function keys enable speedy input of commonly used

# Computer that looks like the future



Durable ebony glass top plate and ebony finish acrylic finish.

Separate power supply for up to three floppy disks and 2 hard disks.

Provision for up to 3 x 1.2 Megabyte IBM standard floppy disk for fast, reliable data storage.

Provisional for removable cartridge drive.

Protected illuminated reset switch.

Winchester Hard Disc. 11, 16, 35 Megabyte & larger.

Provision for additional Hard Drive.

Castors for ease of movement



functions. High resolution coated screen minimises eyesrain. Our unique 'unserial terminal' rivals the best dedicated wordprocessors.

## Multiuser vs Networking – avoid an information bottleneck

As your needs grow, you may need to give more than one person access to your data files – sales and accounts, or say wordprocessing and stock control. Most personal computer being sold for data processing (wrongly we believe) get around this by 'networking' several personal computers to a common 'hard disk'. This arrangement is *unusably slow* in a most business situations. As the number of users grows, the situation gets *much worse*. Universe offer a much faster *Multiuser System*. Each user shares part of the central computer, with a massive increase in speed of access to information.

## Multiple Programme Selection. Unique to Universe but Essential to Every Business.

Getting the most from your computer

means being able to get fast access to your programs and data. Yet most computers only let you do one thing at a time. Changing between programs means closing down data files and programs and opening up others. This often takes *several minutes*. Too bad if the man is on the phone right now. You could be better off with a filing cabinet! Universe gets around this with a unique Multiple Program Selection facility which allows you to switch between up to 10 programs within 6 *seconds* when you are *right in the middle* of another program. Go from writing a letter to checking your stock to sending an invoice *instantly*. This immediate access means never having to scribble things onto bits of paper and enter them later – a continuous problem with most computer systems. A further unique Universe enhancement allows you to instantly direct data to any of 9 printers. These are just some of the ways in which Universe is built to grow with your future.

# AED – the Company behind Universe

At AED there is only one kind of computer we are interested in building for you – the best. Our company's background has been in industrial control where computer breakdowns cost lives. We have brought these uncompromising attitudes to quality and reliability when we build every Universe. In contrast to the majority of computers being offered for business, your Universe is built by a relatively small team of quality conscious and dedicated technical staff.

## Full Field Support

AED were the first company in Australia to introduce full 12 month *on-site* maintenance and support (now extendable to 2 years at time of purchase). Our computer is designed for fast, easy, field maintenance. Most problems, when they occur, (which is very rarely!) can be corrected in minutes and usually involve plugging in a new card.

Field service is presently within 24 hours on the east coast and within 48 hours for country areas for NSW Victoria and ACT.

Our network is being aggressively expanded.

If you are in a remote location or country area, where service is difficult, the Universe's high reliability and modular construction make servicing faster and easier than on any other machine. Universe *really is* built for Australian conditions!

And if you ever have a problem you can pick up the phone and talk to the engineer who design your computer and very likely to the technician who commissioned it. No other computer company can offer you this standard of service at any price.

When you need them, we supply service contracts, phone support, training, custom programming and advice on updates. We will always take an active interest in our existing customers since you will eventually come back to us as your needs change and grow. You will be treated as if you are a new prospect, whether you have been a Universe owner for one or ten years.

We all take personal pride in providing a top quality product and in continually refining it in response to the needs of Australian business.



Subassembly testing

## Our Aim – Total Reliability

One of our major aims with Universe is to bring downtime to zero. While other manufacturers talk about *low* levels of breakdown, we go for *no* breakdowns. We take pride in our equipment having been chosen for installations as far afield as Mexico (industrial control) and Tonga (Government) and are being used every day in practically every Australian University as well as many divisions of the CSIRO. Our equipment provides the total reliability as well as the high standards of performance that these companies and institutions require.



All service is carried out by AED personnel. We are not prepared to trust our reputation to third parties.



Final checking and assembly

Fill in the coupon below for our free Information Pack, including the 'Who, What, When and How book of computers'. Or call your nearest AED sales office for a consultation.

Name \_\_\_\_\_

Address \_\_\_\_\_

Postcode \_\_\_\_\_ Ph: \_\_\_\_\_

**Sydney:** 24 Darcy Street, Parramatta.  
(02) 689 1744, 636 7677 TLX AA 70664



**Melbourne:** 53, Waverley Road,  
East Malvern Vic  
(03) 211 5542 TLX AA 30624  
**Canberra:** 217 Northbourne Ave.,  
Canberra ACT (062) 47 3403 TLX AA 62898



# Friday

the second choice produces the main menu for retrieving data: view/edit records, quick report, custom report, report look-up, mailing labels and a couple of quit options (to the main menu or the previous menu, which in this case is the main menu).

Selecting A at this point (to view/edit records) prompts us with the file and display form that Friday! will use to display the records. Hitting return here will move us into the search menu, which allows us to specify a retrieval rule (such as COMMISSION > 100), a sort order, and a search range. For just browsing through the file, none of these is required, so just hitting returns will bypass this menu and then display the first record in the file.

The status line now displays the record number together with the other information mentioned above. Below that come the various fields in the database, with prompts (the field names) and delimited with square brackets. At the bottom of the screen comes a menu of available choices. The user can edit the record, delete or undelete it, move forward or backward, enable or disable half intensity video, do a quick find on a key field or exit to one of several menus – the search menu (above), the layout menu (which allows the creation of custom forms) and the main menu.

Full screen editing is very much the same as in dBase II, using the control-S, -D, -E and -X keys for cursor movement, together with control-G, -Y, -V and others for deletion, insertion and so on.

Adding records to a file is done in very much the same way as for dBase II, although the add menu has a number of other options for viewing records in the file – basically the same as the view/edit menu.

## Creating a Database

Creating a database is also analogous to dBase II's operation, but is done through a menu-driven scheme, rather than the simple prompting of dBase. Up to 32 fields can be created, with a total length of up to 999 characters, and the user can use full-screen editing to design the database layout. Once the design is complete, it can be saved, and Friday! then goes into the Enter Data mode.

Once a database has been created, it is possible to define fields in it as computed

fields; that is, fields which take a value calculated from other fields. This is done from the second option of the Other Activities menu, which allows us to enter the formulae for the computed fields.

Friday! provides two kinds of reports. Quick Reports are basically the same as the REPORT verb in dBase, but the user can fill in a form to generate the report, rather than answering questions, as dBase prompts. In addition, Friday! prompts with the field names and their widths, rather than requiring the user to remember them.

Custom Reports are slightly more sophisticated from the point of view of layout, but not so smart at subtotalling. The custom report is probably best used for the generation of form letters, listings and the like.

Finally, Friday! will also allow the printing of mailing labels, which can be designed by the user. From one to four labels can be printed across the page, with whatever layout desired – unlike some simple-minded labelling programs which simply print the contents of every field.

The Other Activities menu allows the user to perform a number of associated tasks, like copying files, changing the sort (index) order, setting the date, drive defaults and passwords (Friday! has a password protection scheme, by the way) and defining formulae for computed fields.

## Overall Impressions

My overall impressions of Friday! are that it is a well thought-out program, with particular attention being paid to making it easy to use – yet powerful – and well documented. It certainly does not compete with dBase II and other database languages, particularly since it is restricted to working with one file at a time, yet it has its place.

The Friday! user who is familiar with dBase II will see lots of familiar concepts and ways of doing things which are explained in different terms. For example, the dBase II character, numeric and logical fields are described as Anything, Math and Yes/No fields – which probably make more sense to the non-technical user. The people at Ashton-Tate are probably well aware of criticism that has been levelled at the dBase II documentation (if they're not, I'd be surprised), and have gone to considerable

lengths to ensure that the Friday! manual is up to scratch.

To be fair, a lot of criticism of the dBase II manuals has arisen because the program is being bought by people for whom it was not designed; it was originally designed for experienced programmers, not end users. Friday!, on the other hand, is specifically aimed at end users, and the manual has been designed with them very much in mind.

The first part of the manual is tutorial in nature; it covers definition of terms (like the control key) and then goes on to take the user through a number of exercises on a sample database. The manual has a folding spine which can be used as a bookrest beside the terminal.

Then comes the reference section, based on the prompt numbers of the various screens. This is well organised and comprehensive, yet manages to avoid jargon quite well. However, it's not possible to avoid jargon totally, so there is a glossary section next, and then a number of appendices, which cover infrequently used details like installation, making back-ups and using Friday! with dBase II.

The typical Friday! user is likely to be somebody who has tried to get to grips with dBase II and given up hope, or a corporate executive who wants a system which is simple to use, yet provides sophisticated options, plus the ability to grow into a more powerful dBase II-based system whenever required.

The major drawback with Friday! is that it is not terribly quick. This is because the program comprises 32 command files which are perpetually being read into memory whenever the user selects options from menus, and because of the additional interpretive overhead of dBase – even the RunTime version. However, the system is still quick enough for the vast majority of applications.

There are a few other little points that caught our attention; for example, when indexing on a field such as surname, Friday! does not allow upper case conversion, causing confusion with names like 'de Vries'.

Our copy of Friday! was supplied by the Ashton-Tate master distributors in Australia, Arcom Pacific, but it should be available from any good computer store. The retail price is \$360.00 including sales tax. □

*Everyone's familiar with computers being used for purposes such as accounting, but less usual areas for application are in customer service and workshop productivity. That's where a Sydney engineering firm installed its first microcomputers, however.*

# Better Service by Computer

BY NORMAN KEMP



Mr Philip Leach, Managing Director of Haden Engineering (standing), and Mr Dennis Garnsey, National Service Manager.

**A** busy managing director of a Sydney engineering firm found programming an IBM Personal Computer such a diverting pastime that the result has been a service department system which not only is making his company more efficient, but also could be used in similar organisations around the world. The system has taken almost a year to complete, and the company managing director, Philip Leach, is now writing the manual which will be used for employee training at the head office and in branches.

Neither Mr Leach, who is managing director of Haden Engineering Limited, of Rosebery, NSW, nor his national service manager Dennis Garnsey had any formal training on computers when they decided to buy an IBM and adapt it to some of the company's works operations.

Haden Engineering has an IBM System/34 for its day-to-day order entry and office accounting procedures, but the IBM-PC was purchased independently as an aid to customer service and workshop productivity. It will increasingly be used

to develop programs for many of the company's diverse activities. As more programs are devised for various departments, the number of PCs will be increased both in head office and branch locations.

Haden Engineering is the Australian arm of a British-owned group with worldwide subsidiaries. One of its main operations involves the design, procurement, project management, construction and maintenance of mechanical and electrical services for building and industrial processes throughout Australia. It has a



substantial commercial activity in operating a 24-hour maintenance facility, including radio-controlled fleets for servicing air conditioning and refrigeration installations, and a variety of mechanical, electrical and fire protection systems. In total, the company provides services and equipment for more than 400 customers, and until recently it had been keeping all its records manually in the administration department.

"After studying different aspects of the company, we decided that the personal computer should be used where there was the greatest concentration of manual work, in order to make it less labour intensive," said Mr Garnsey. "Our immediate problem was that neither of us had any detailed knowledge of programming a computer, and we did not want to employ expensive assistance for a job we believed we could do ourselves."

Fortuitously, Mr Leach, who holds an engineering degree, had been practising with a home computer as a hobby. When the company decided to buy the IBM-PC from ACI Computing Services, of Sydney, for rather more advanced and professional purposes, it also acquired a Nucleus program generator package. Developed in Britain by Compact, this package is designed to assist inexperienced users to write programs in Microsoft BASIC.

When he could snatch spare time from work, Mr Leach spent many hours gradually mastering the intricacies of the package and learning MBASIC language. With the assistance of Mr Garnsey, who supervised the details of transferring the manual procedures from the office and maintenance section into the mystic code of the computer, a program was gradually built up for handling service calls from the company's list of customers.

**Coded Customers**

When a customer phones for service a code number is entered into the computer, which instantly finds and displays any records of previous calls. The machine then prints out a labour docket, which is kept in the service department. A maintenance operative is notified, and a further ticket for this department is prepared. Details such as hours worked and materials used are entered later, and

from this information the computer automatically calculates costs and produces an invoice.

The system will eventually be extended to cover more information from works dockets and plant records, and to produce a wide variety of management reports on equipment inventory and job estimations. The project, which started in May 1983, took until December to begin the first trials, and modifications continued until April this year before the system was implemented in practical form.

"By that time, an avalanche of office paperwork had been converted to the computer system," Mr Garnsey said. "Now the manual is being written in a manner which will be easily understood by the operators in each state who will be using the system. We know documentation is often notoriously bad for users, but we will be taking great care with our own."

In Sydney, there will be three operators, who are currently being trained, and one or two will be selected from the existing staff in other states when more personal computers are purchased. These will continue to be IBM-PCs, as Haden Engineering wants to ensure that complete compatibility is maintained in all locations throughout the lifespan of the machines.

The PCs are being expanded with additional memory and hard disks; in this area, another company decision was to achieve economy by buying the IBM and adding third-party hard disk peripherals, as this gave a significant saving compared with the cost of IBM's own XT models. The standard 64K internal memory of the IBM-PC has been increased to 128K, and the present system uses 18 megabytes of hard disk storage for the operational programs with six megabytes of back-up. Later changes to the programs will be carried out on removable hard disks, which will be shipped to the other states for copying as required.

Other companies in the Haden group, and particularly the parent organisation in Britain, may use the Australian system for their own service units. With little modification it can be used in Europe or the US, and discussions which may shortly lead to overseas trials have started, while the present system continues to be developed for new applications inside Australia.

PRINTER & TERMINAL  
**CABLES**



ALL SERIAL ..... \$18.00  
ALL PARALLEL..... \$32.00

**SUIT**

OSBORNE, IBM, COMMO-  
DORE, APPLE, TANDY, KAY-  
PRO, ETC., ETC.

**CONNECTORS**  
SOCKETS & CABLE



**QUALITY GOLD PRODUCTS**

25W MALE ... \$2.60  
25W FEMALE ... \$2.90  
25W RIBBON ... \$9.00  
36 WAY SOLDER ... \$12.00  
36 WAY RIBBON ... \$11.00  
40 WAY EDGE ... \$8.00

WRITE FOR FULL PRICE LIST

**PRINTERS**



120CPS  
SAME PRICE AS 80CPS  
ONLY \$545.00  
INCLUDES CABLE AND TAX

PLEASE SUPPLY THE  
FOLLOWING

.....  
.....  
.....  
.....

BANKCARD No. ....  
ADD 10% P & P PRINTER ONLY  
\$8.50 P & P.

ARBITER ELECTRONICS  
SHOP 82 STAFFORD CITY  
STAFFORD ROAD  
BRISBANE, QLD. 4053

# If you're thinking about leasing a new Microcomputer consider the following 6 points very carefully...

**1. The Adler Total Support System**  
Every Adler Microcomputer is manufactured by Adler, sold by Adler, programmed by Adler and serviced by Adler. In addition we can provide training for you and your staff to ensure the complete smooth running of your microcomputer. Who else gives such support?

**2. Adler and Ergonomics**  
At Adler we recognise the strain involved in repetitive computer operation; that's why our Alphasonic P30 and P40 models are ergonomically designed with a super-thin keyboard (we defy you to find a thinner one!).

**3. The Adler Software**  
Adler has been specialising in software for business and professional use for years. Whether it be general commercial software or software for specific industries, Adler has a large range available from many sources including its own development group. We'll also arrange to tailor software to suit your own specific needs.

**4. Adler Technology**  
Adler has designed its P30 and P40 models with dual 8 and 16 bit processors to give you the best of both worlds. You can take advantage of the vast range of 8 bit CP/M software and also run the latest releases of 16 bit CP/M or MS-DOS software.

**5. Adler Capacity**  
Adler's P30 utilises 800 KB floppy disk drives. That's 2½ times the capacity of the 320 KB drives offered by a lot of our competitors and if that's not enough our P40 offers winchester fixed disc storage.

**6. Adler Growth**  
We recognise the need for growth in the capacity of your computer, so we provide our fileserver and network. Whether your requirement is 2 or 200 personal or business computers the Adler network will connect them all to a large central storage facility offering 10 to 85 megabytes of on line storage. It's so simple to use you won't even know you're connected to the network.



**TA TRIUMPH ADLER**

*"A world leader in Communications"*

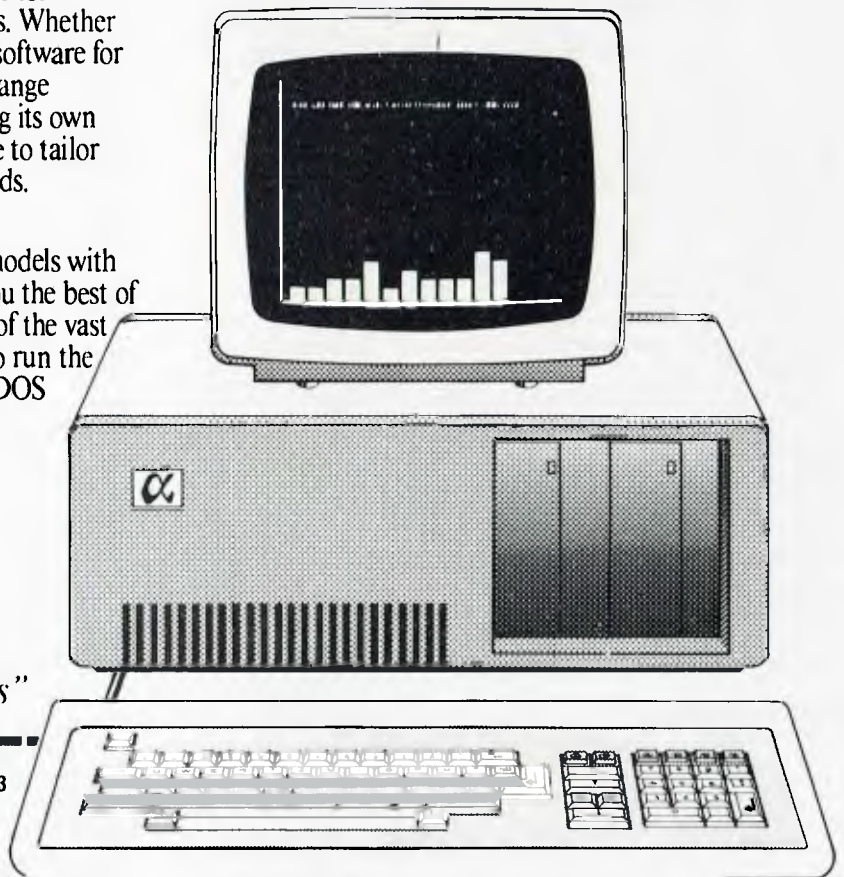

**TO: ADLER BUSINESS MACHINES PTY. LTD**  
Cnr. Waterloo & Lane Cove Roads. North Ryde. N.S.W. 2113

- I am interested in a demonstration on the Alphasonic  
 Please send me further information on the Alphasonic

Name \_\_\_\_\_

Company \_\_\_\_\_

Address \_\_\_\_\_

Tel: \_\_\_\_\_ PC \_\_\_\_\_

For a demonstration of the Adler Alphasonic and how it applies to your business, contact Adler today.

**Sydney:**  
888 7644  
**Newcastle:**  
69 2483

**Melbourne:**  
267 5311  
**Brisbane:**  
52 0261

**Adelaide:**  
223 6222  
**Perth:**  
328 1511

**Hobart:**  
34 6011  
**Canberra:**  
80 5088

*Ballet and computers don't connect very easily in most people's minds, but as in all spheres of the arts, computers are proving invaluable in helping companies to return profits in a high-cost, high-risk area.*

# Put on your Dancing Shoes

BY NORMAN KEMP

**W**hen the final curtain falls on the career of a ballet dancer there is often not a clear future ahead. Love of the theatre, of playing a variety of roles to appreciative audiences, and a genuine feeling for the masterworks of composers and choreographers create an emotional attachment to a company of performers that is too strong to be easily discarded. Most remain with a company until their limbs are no longer sufficiently supple or have the strength for arduous performances; then their talents are generally turned towards teaching and encouraging a new generation of pupils in the arts and traditions of classical styles.

Paul Wright was a ballet dancer with a different view from most of his contemporaries when he felt his time had come to leave the ballet. During a happy and successful career with the Australian Ballet Company, he developed an unusual hobby; he made dancing shoes for himself and other members of the company. When he decided to retire from active stage work 17 years ago, he had no doubts about his future — from his experiences as a backstage cobbler he would set up Australia's premier firm for making ballet shoes.

Last year, the business that Paul Wright has built up, Paul Wright Pty Ltd, was one of only two Queensland winners of the prestigious National Small Business Awards. From his hobby of making dancing shoes as a garage industrialist, he has grown to become the proprietor of a small but thriving factory near Jindalee, employing 50 people and making 500 pairs of shoes a day.

Although the main range has been in ballet, which has included exports to New Zealand, Norway and now to the United States, Paul Wright is also making a variety of shoes for women. In for-



mal wear these have included shoes for policewomen in Queensland, Victoria and the Australian Capital Territory — a far cry from tripping the light fantastic in ballet — and he has also designed a set of casual footwear named 'Kinks' which

sells through more general outlets, and will soon represent about half the daily output. A new style soon will be an aerobic shoe to suit physical movements of wearers.

"Up until last year the business was being run on manual methods without any real control of materials or costings," Paul said. "Although our production was steady, this did not seem to be truly reflected in our profits, which were tied up with growth and rising prices of materials in a way that I did not fully understand."

Paul consulted his financial adviser and accountant, John Hodgkinson, who is also a dealer for Commodore computers



Brisbane-based cobbler, Paul Wright, displays his shoes which — with the help of a computer — won him a National Small Business Award; on the right is John Hodgkinson, who wrote the company's programs.

# YES OSBORNE



**TOTAL VALUE**  
**\$8336.25**  
**FOR**  
**\$3250**  
 UNTIL JULY 30 1984

## AUTHORISED OSBORNE EXECUTIVE DEALERS INCLUDE:

**NEW SOUTH WALES**  
 B Office Electronics — BALGOWLAH  
 (2) 949 7195  
 Complete Solutions — SURRY HILLS  
 (2) 331 6799  
 Delta Computer Systems — PARRAMATTA  
 (2) 633 4055  
 Direct Computer Sales — HURSTVILLE  
 (2) 570 8344  
 Foremost Office Equipment — PARRAMATTA  
 (2) 635 5477  
 Grace Bros Business Centre — SYDNEY  
 GEORGE STREET — (02) 238 9111  
 Irena Cash Registers — DUBBO  
 (69) 82 5833  
 C.C. Computing — SYDNEY  
 York Street — (02) 290 3344  
 Topi-Kat — KATOOMBA  
 (47) 82 2407  
 Town Computers — NEWCASTLE  
 (49) 52 5105  
 Bathurst Computer Services — BATHURST  
 (53) 31 2833

**AUSTRALIAN CAPITAL TERRITORY**  
 Boulevard Business Services — CANBERRA  
 (62) 48 5411  
 C Electronics — HOLT  
 (62) 54 7608

**NORTHERN TERRITORY**  
 Avionics — ALICE SPRINGS  
 (89) 52 3517

**QUEENSLAND**  
 Compeltron — MAYNE  
 (07) 52 9700  
 Comsoft — SPRING HILL  
 (07) 229 0066  
 Myer Computer Centre — INDOOROOPILLY  
 (07) 378 5111  
 Scarborough Fair Computers — SOUTHPORT  
 (075) 32 5133  
 Servatronics — ROCHDALE  
 (07) 341 5340  
 Town and Country — TOWNSVILLE  
 (077) 75 4000  
 The Byte Shop — NEWMARKET  
 (07) 352 6621  
 The Byte Shop — TARINGA  
 (07) 371 0711

**WESTERN AUSTRALIA**  
 Amity Computers — ALBANY  
 (098) 411 6060  
 Computer Country — PERTH  
 (09) 328 4644  
 Ossie Computers — CLAREMONT  
 (09) 384 5787 — W.A. DISTRIBUTOR

**SOUTH AUSTRALIA**  
 Micro-80 Computing Centre — ADELAIDE  
 (08) 211 7244  
 Myer Computer Centre — ADELAIDE  
 (08) 217 0123

The Copy Centre — WHYALLA  
 (086) 45 7755

**VICTORIA**  
 Almer Distributors — OAKLEIGH  
 (03) 569 0169 or 569 6911  
 Data Parts — SHEPPARTON — (058) 21 7155  
 — ALBURY — (060) 21 8080  
 — BALLARAT — (053) 31 3399  
 — BENDIGO — (054) 43 4886

Direct Date — ARMIDALE  
 (03) 20 6949  
 Geelong Computer Centre — GEELONG  
 (052) 22 2844  
 IMA Computer Centre — SURREY HILLS  
 (03) 836 8835  
 Nucleus Computers — MOUNT WAVERLEY  
 (03) 232 6370  
 Tech-Rentals — RINGWOOD  
 (03) 879 2266 — NATIONAL RENTALS

**TASMANIA**  
 Coastal Computers — BURNIE  
 (004) 31 7959  
 Strawberry Enterprises — BERRIEDALE  
 (002) 49 1814

- All sales and related inquiries must go to the dealers
- All Engineering and machine faults must go to Hills Industries in your Capital City.

• **OSBORNE AUSTRALIA (02) 290 3344**

**NEW Hills COMPUTER SERVICE** IN YOUR CAPITAL CITY  
**FULL 6 MONTHS WARRANTY**  
 Contact Osborne Australia for depreciation allowance

**PARTS AND LABOUR**

FREE  
VERBATIM DATA  
HEADCLEANING KIT  
VALUE \$13.25

# is Australia's Number 1 now is the time to buy ... with four great offers

INCLUDED IN OUR ONE LOW PRICE



PURCHASE AN OSBORNE EXECUTIVE BEFORE JULY 30 AND RECEIVE THIS ACCOUNTING PACKAGE WORTH \$1200 FOR FREE.

The **MULTILEDGER Accounting System** includes a complete General Ledger, Debtors, System and Creditors. It is written in Australia and developed for total compatibility with the Executive. Along with **Multiledger** you will also receive the standard **OSBORNE** software package —

- CP/M 3.0 Plus, advanced CPM operating system
- Wordstar, wordprocessing and Mailmerge
- Supercalc, spreadsheet and Financing Modelling
- Personal Pearl, full database management
- CBASIC and MBASIC, Programming languages
- UCSD, p-System Universal Format system
- Over \$400 worth of CP/M 3.0 Utility programs
- MAC Assembler etc.
- CHRS Generator

# Plus ...

If you twist your dealers arm ...

**A HIGH SPEED DOT MATRIX PRINTER.**

**TOTAL VALUE**  
**\$8336.25**  
**FOR**  
**\$3250**

UNTIL JULY 30 1984



FOR  
**\$50**  
VALUE \$425

The **OSBORNE EXECUTIVE** with complete software, **MULTILEDGER**, Dot Matrix Printer and 6 months Nationwide service and backing for \$3,250. And don't forget to claim your **18% Investment allowance** on top. If that doesn't solve your year-end headaches nothing will!

*Contact Osborne Australia for depreciation information*

**THE AFFORDABLE PORTABLE**

*See your dealer for a demonstration before July 30*

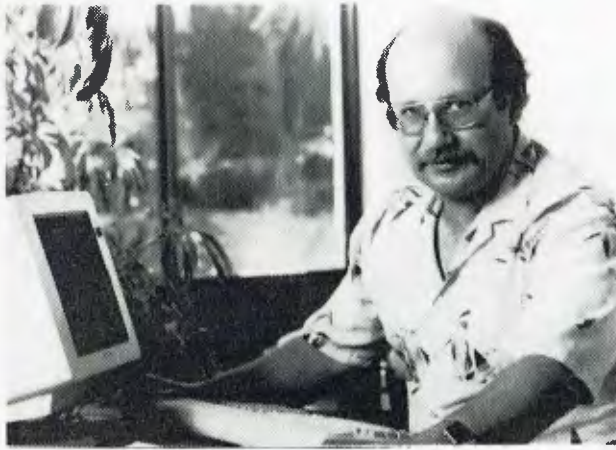

Dick Blume, Computer Software Consultant

**“I’ve been writing business programs on the same computer for 4½ years.**

**It’s still state-of-the-art.”**

## How I did it

**B**uying the right business computer was one of the hardest decisions I’ve ever made. As a software consultant I need a computer that is always the best available. Impossible, you might think in the fast changing world of computers? So did I until I bought a Universe.

**‘I bought the very first Universe – so long ago they hadn’t even invented the name!’**

At the time (over four years ago), my Universe was ‘state-of-the-art’, with a 4MHz Z80 (8 bit), 48K of memory, 80 column display and 600K of disk capacity. There is no way this would be adequate for me or my clients now.

**‘Without the Universe, I could not have stayed state of the art’**

If I had bought any other computer it could not have been upgraded sufficiently to keep up with my work needs. I would have been forced to upgrade by selling the machine or compromise in my work for my clients.

**‘My Universe has been upgraded 8 times – it’s a great investment’**

I like to boast that my Universe was running both 8 and 16 bit software before IBM ever thought of the PC. But jokes aside, owning a Universe has enabled me to get the benefits of the latest technology **first** and at low cost. I now run 8 and 16 bit processors, more and faster memory, a different terminal, more elaborate I/O facilities and more disk capacity.

**‘Software and data are always secure’**

Working for R.M. Smith, one of Sydney’s fastest growing wholesale grocery firms has taught me how essential it is to be able to upgrade while securing software and data. I am lucky that R.M. Smith use Universe. As a result, their computer system has been able to cope with 300% expansion in 2 years and has never lost one bit of data during this time. Reliability has been outstanding by any standard. Total downtime, with 3 machines has been 2 hours total. Whatever way you look at it, the Universe is one hell of a

computer for a business to have on its side.”

### Universe Supercomputer Specifications

- Runs both 8 and 16 bit, single and multiuser.** All standard operating systems including CP/M & CP/M 86 with Multitasking, CP/M 8-16 ‘PLUS’ (8 and 16 bit at the same time), MP/M 8-16 ‘PLUS’ and MP/M 86 (Multitasking, Multiuser 16 bit with ultra high speed 10MHz processor). Access to a massive software base. Expansion as and when you need it.
- Multiple Program Selection (MPS).** Our version of CP/M can swap between any mixture of up to ten separate programs almost instantly.
- Memory may be expanded up to 1 Megabyte and disk storage up to 200 Megabytes.**

Impressed? Astounded? Then call your nearest AED sales engineer for the whole story.



**Sydney:** 24 Darcy Street  
Parramatta (02) 689 1744, 636 7677.  
**Melbourne** 53 Waverley Road,  
East Malvern Vic (03) 211 5542.  
**Canberra** 217 Northbourne Ave.,  
Canberra ACT (062) 47 3403

# UNIVERSE SUPERCOMPUTER

# Put on your Dancing Shoes

through a firm which he operates as Austcomp. Without previous experience in computers, Paul opted for a basic system with a Commodore 8000 Series central processing unit, standard accounting packages and specially written job costing software. Since the implementation of this unit, which included a one megabyte disk drive and 132-column printer, it has been expanded to an 8032SK processor with 64K internal memory to run VisiCalc, an 8250 two megabyte disk drive and a 6400 letter-quality daisywheel printer. The Commodore word processing system, Wordcraft, has also been added.

## Job Costing Program

A principle feature of the system is the job costing application program written by John Hodgkinson, which has been designed to provide comprehensive information about the effects of wages and plant productivity on overall profits. The



jobs have been divided into various segments, which can be examined on a monthly basis. There are 56 dissections on the program, although only about a dozen are scrutinised regularly. One of the most frequently used provides a comparison of overheads such as wages with the amount of profits recovered from production and factory throughput. It also provides for controls on areas of

spending, which can be checked more often, and allows for quicker adjustment to cope with changing situations, such as variations in inventory and quantities of different materials being held in stock. The accounting system has been modified to fit in with the job costing program so that the general ledger can be produced with accurate monthly figures.

"Further needs are being identified which will be incorporated in new programs," Paul said. "Software has proved to be the major contributing factor in helping the company to achieve its success in winning the award, by enabling us to keep a firm check and control over many of the aspects of the business."

For the future, Paul is planning to expand his lines, and will be using the computer for forecasting and estimating forthcoming costs, so that there will be less risk in expanding too fast in an area of growth with insufficient information to back his business judgments. □

## Introducing the VISUAL 1050 ...

### The Complete Professional Solution at an Unbeatable Price

**Complete Solution.** The VISUAL 1050 is an advanced personal computer system designed especially for managers and professionals. It comes complete with top-rated software and high-performance hardware:

**Words, Numbers and Graphics.** Whether you work with words, numbers, or graphics, the VISUAL 1050 speaks your language. You get WordStar™, Multiplan™, and Dr Graph™.

**Unbeatable Value.** You get the best and most popular software packages, ready to run on hardware which offers the features and quality you should demand.

**\*\$2995** is the total retail price for the VISUAL 1050.

Dealer Enquiries Welcome

Generous OEM and Qty discounts

Available from:

**KENELEC (AUST.) PTY. LTD.**

(INCORPORATED IN VICTORIA)

48 Henderson Rd, Clayton, Vic. 3168 Telephone (03) 560 1011

#### FEATURES:

Z80A & 6502 Processors  
128K RAM  
Serial and Parallel Ports  
Dual 400 KB Drives  
Optional 10 Meg Winchester  
Tilt and Swivel Display  
Optional Software  
Low Profile Detached Keyboard



NSW: (02) 439 5500 Q'LAND: (07) 393 0909  
SA: (08) 42 6877 WA: (09) 322 4542

\*Plus 20% Sales Tax.

# PACESETTER

**Professionals in Peripherals.**

**SILVER-REED Daisy Wheel Printers**

17CPS

**\$734\***

25CPS

**\$1097\***



40CPS

**\$1750\***

- \* Variety of Speeds
- \* Quiet operation
- \* Versatile
- \* Dependable
- \* Compact space-saving design
- \* Complete range available
- \* Options

### Special Features

- \* First rate letter quality
- \* Bidirectional
- \* 17-40CPS
- \* 13-17" Paper widths
- \* Self test function

\* Supports a full range of word processing functions including bold print, subscript, superscript plus underlining functions.

\* Daisy Wheel and Ribbon Cartridges can be changed easily, quickly and cleanly.

\* Prices do not include sales tax

**Our prices to OEMs and Dealers are EVEN BETTER!**

FOR FURTHER INFORMATION CONTACT:



**PACESETTER  
PERIPHERALS**

A Division of VSI Electronics (Australia) Pty. Ltd. - Incorporated in S.A.

16 Dickson Avenue, ARTARMON 2064, N.S.W. PHONE: (02) 439 4655

Adelaide (08) 267 4848 Brisbane (07) 229 8827 Melbourne (03) 818 0688 Perth (09) 328 8499

*When you hear of a chain of 20 shops being computerised, you expect the machine adopted to be at least of the capacity of an IBM-PC or similar. But if the people involved are keen enough, they can create a perfectly adequate system on a computer generally regarded by industry pundits as a 'toy'.*

# Tom Thumb vs the Goliaths

BY NORMAN KEMP

**A**ccording to conventional marketing wisdom, a produce business with a turnover of several million dollars a year, multiple retail outlets and which is also an important volume supplier of goods to large organisations should be computerised, using a machine with a storage capacity measured in megabytes and an operating system expanded for the largest spreadsheets. But if the business does not know these things, and can look after its needs with one of the most elementary microcomputers ever marketed – the Dick Smith System 80 – which was programmed to start with as a hobby, computer salesmen who call with the latest flashy models will be told in nanoseconds to be on their way.

It was not by design but rather a series of incidental happenings that 34-year-old Ian Harris, son of the founder of the retail butcher chain, Sirrah Meats, three years ago walked into a Dick Smith shop as a rank novice, and after much nervous questioning bought a System 80 computer as a hobby.

"I knew nothing of computers at the time," Ian said. "Back in 1975 when I was at the University of NSW I had known people who were studying computer science at Sydney University, but their jargon didn't mean anything to me. I had always thought of computers as mammoth things that would cost millions of dollars, and just would not suit our business."

The Sirrah Meats business at that time was just beginning. It had been preceded by Harris Meats, started in the 1930s by Kelvin Harris, which ran into financial problems in the mid-1970s recession and had to be restructured. Out of that came the new name – no prizes for guessing where it came from – for the company which now operates from Sydney's

Bondi Junction and runs 20 butchers' shops, mainly in Sydney shopping centres, and has contracts to supply Qantas and a number of large restaurants and catering organisations.

## No Plans for Computers

After leaving university, Ian Harris went into the family business as a clerk, and worked for a period in the company's smallgoods factory at Botany before joining the organisation in a higher administration role, where he became familiar with the operations of the shop outlets and their management. The idea of buying a computer was not in his plans for running his part of the business at the time, but on passing a Dick Smith shop in the city one day he became fascinated with a demonstration of a small

computer that was going on.

"I went in the first time to have a look at it, and then returned on several occasions to push a few buttons," he said. "I thought it might be fun for a few games, and eventually the salesman's pitch sold me. I took it home, and found I didn't even know how to turn it on. The manual got me started but wasn't much help after that – in fact, it was for a different system, and quite dreadfully written. Eventually after I had it going for a while I learned how to make the machine say 'Hello' and finally it ran a peculiar little game."

When he bought the System 80, which had 32K memory, Ian had also purchased a couple of 100K disk drives and a dot matrix printer, an expenditure of around \$4000, which was a larger than average



The Dick Smith System 80 that Ian Harris runs the Sirrah Meats business on.

## Tom Thumb vs the Goliaths

**NOW...**  
**mail order**  
**convenience**  
**and discounts**  
**with...**

**PC**  
**CONNECTION**  
 AUSTRALIA

Connect with us if your IBM PC needs peripherals. We have the hardware, the software, the knowledge and the prices.

**SOFTWARE:**

Lotus 1-2-3.....	675
MultiMate.....	535
dBASE II.....	650
Quickcode.....	305
Wordstar.....	515
ProPak (Wordstar, Mailmerge, Spellstar, Starindex).....	715
VisiCalc Adv. Version.....	505

**HARDWARE:**

Quadram Quadboard 64K upgradable to 256K, with calendar clock, serial and parallel ports.....	525
Sigma Design SDI-ESC 64K upgradable to 256K, with calendar clock, serial and parallel ports.....	480
Tandon TM100-2 320K disk drive.....	425
Memory 64K Upgrade Set for IBM system board, or any memory board..	75
Verbatim Datalife DS/DD box of 10...	52

**PRICES INCLUDE SALES TAX**

Orders must be pre-paid. Add \$5 per order for postage & handling. Prices subject to change without notice.

**SEND FOR OUR CATALOGUE**

POSTAL ADDRESS:

**G.P.O. Box 486G,  
 Melbourne, VICTORIA  
 3001, Australia**

Your IBM PC Specialists

purchase for a home computer system even as recently as 1981.

"After a couple of months of experimenting, I had ceased to be fascinated with games, but I realised there were quite a lot of other things it could do," he said. "Unfortunately none of these was in the manual, and I was so mystified I had to make a number of visits back to the shop to get further information, as well as some assistance in learning the BASIC programming language.

"At that time I had realised that with 20 shops we were keeping 20 sets of records, and doing all our book work 20 times. Our managers worked on Saturday mornings compiling returns every week on perishable products, which varied in price and often changed before being sold to the public. These would be phoned back to the head office after the weekend, and kept about four or five staff tied up sorting them out through an incredibly long Monday and sometimes further into the week. That also meant some of our retail financial results were late, and made checking very difficult. Errors tended to be repeated, and the chances of mistakes were rife.

"So I decided to write a trial program to assess some of the trading figures, and it worked. At first the computer was used as a large calculator and none of the information was stored. Then I learned how to use the disk drives and it opened a whole new world. When I look back on that original program it seems strangely long-winded, but it was the basis for all the programs I have written subsequently."

**Complete Series of Programs**

Over the past 12 months, Ian has virtually completed the series of programs, which now covers most of the company's operations. The System 80 has been extended with two 64K expansion units, and the number of disk drives doubled to four. A word processing system has been added for form letters and producing memos to the shops.

Although Ian has considered a hard disk, he does not believe it is necessary at this stage as each shop's records for 12 months are contained on an individual single 13 cm floppy, and are easily retrievable. Other aspects of the business, such as the TAA and Qantas contracts and factory smallgoods production, are

also contained on separate disks. In all, the system is keeping track of the weekly business affairs of a fast-moving retail and distribution organisation that is turning over revenues in excess of \$3 million a year.

"Introduction of the computer into the office system caused some resistance," Ian said. "At first staff thought the operations of the business would have to be changed to suit the software, but I wrote the programs so that the printouts came out looking exactly the same as the manual records they were used to.

"Some of the managers seemed to be opposed to the computer on principle, but after I showed how it could cut the Monday work down to two people with most of it finished by midday it became more acceptable. I think they also realised I was not spying on them or the way they ran the shops."

The programs are continually being tuned for speedier processing and to eliminate some of the earlier unnecessary writing. An average shop has 40 entries on the stock it purchases, and subsequent sales of smallgoods products and bulk meat, with its grading and classification, together with weights of unsold stock when applicable, are among the information gathered for the computer. The system not only provides a record of individual shops, but also enables them to be compared for performance and turnover.

Because of the continual changes in the market which affect supplies and deliveries of meat products, Ian Harris does not expect the system to be fully operational without further modification. The company has lately consolidated its shop locations to concentrate primarily in Sydney suburbs, and the present system seems to be capable of keeping up with their performance for several years ahead.

Probably few computers of the size of a Dick Smith System 80 are bearing similar responsibility for a large-scale business, and by comparison with many more recent 16-bit computers it is a Tom Thumb in a field of Goliaths. However, whatever the technological pundits may say, the Sirrah system does bear out the enthusiasts' view that the real value to be gained from computing is in the interest and achievement of the user, and the computer is really only a tool made to respond to human ingenuity. □

In the realm of computer learning and imagination, there is nothing like a touch of genius.

*from Chalkboard*  
**PowerPad** *and*

## The touch of genius

PowerPad is the revolutionary new 30 cm x 30 cm touch-sensitive surface that lets you bypass your home computer keyboard. Just touch PowerPad and watch your ideas appear on the screen in living colour.

PowerPad is a drawing pad, a multi-coloured canvas, a piano keyboard, a jigsaw puzzle, a gameboard. It stimulates and reinforces creativity for users of any age. PowerPad turns your computer into an entertaining, learning experience.

Available from Commodore, Apple and Atari home computers.

**\$199.00** rrp.

Ask to see a demonstration of PowerPad at your nearest computer retailer:



For details contact:

Ashton Scholastic  
PO Box 579  
Gosford, NSW 2250  
Phone: (043) 28 3555

# Leonardo's Library

*the software that makes the magic*

Leonardo's Library™, Chalkboard's revolutionary approach to software is structured to provide an entertaining, innovative entrance into the worlds of visual arts, music, mathematics, science, language arts, and social studies. Five strands within each subject area explore the ideas of similarities, patterns, interaction, change and evolution.

Each package includes software in either cartridge or disk format, as well as a tough plastic overlay that is imprinted with each product's unique function buttons and a manual describing a number of learning activities.



# RIFA COMPUTER PRODUCTS ALLOW MORE TIME FOR THE FUN THINGS IN LIFE

## COMPUTER PRODUCTS THAT ARE COMPATIBLE . . .

To meet your expanding needs, Rifa has a wider choice of recognised brands.

Be it personal computer systems, letter quality printers, high resolution graphics colour monitors, or V.D.U.'s – RIFA has the products to suit virtually all of your computer needs.

It's almost a case of "you name it, Rifa has it". Find out the hard facts about software. Rifa will help you get-it-together with the value and economy that suits your budget.

We won't fuzzle you with computer jargon, but we will offer you the most sensible choices from a big range of high quality recognised brands – and they're all in stock too so you won't have lengthy delays.

Talk to Rifa today  
for a no obligation demonstration.

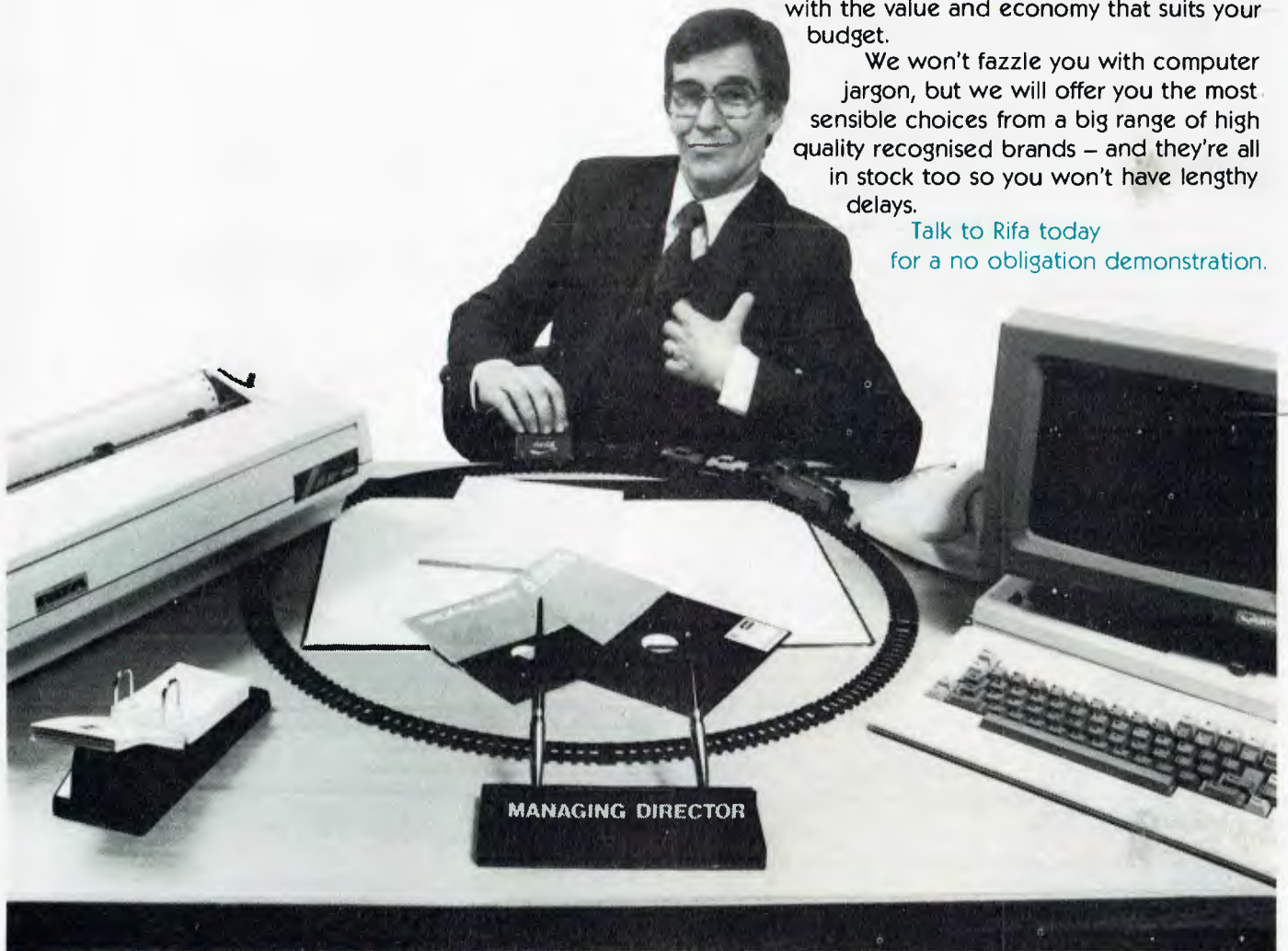

**RIFA**  
COMPUTER PRODUCTS

RIFA PTY. LTD.  member of the Ericsson group

VIC: 1st floor 55 A'beckett Street, Melbourne, Vic. 3000. Ph: 348 1811  
N.S.W. Cross House, 2 Cross Street, Hurstville, NSW, 2220. Ph: 570 8122  
Q'LAND: 243 Grey Street, South Brisbane, 4101 Ph: 44 6673 MC/R/906

*Last month Les Bell introduced the essential statements for programming in dBase. This month he continues with the most powerful feature of the language.*

# Getting the best from dBase

## Part VIII

FIRST OF ALL, apologies for the screwed-up examples in last month's article – our typesetter and proofreaders obviously don't understand the benefits of indentation in programs, with the result that the typeset examples in the last article are a) unreadable, b) examples of the worst programming style imaginable and c) in at least one case won't run. They're repeated correctly on page 93.

It is, of course, absolutely mandatory, in any programming language that will allow it, to indent code inside DO...WHILE or IF...END constructs, and the DO CASE statement requires a further level of indenting for clarity. This makes it much easier to determine which statements are controlled by the DO or IF, and therefore understand what gets done under what circumstances.

### Macros

dBase II's macro facility is one of the most powerful facilities of the language. It's so powerful it's dangerous, and if it wasn't for the fact that some things would be impossible without it (and even more things so much easier), I would want to see it taken out.

Before I explain why, we'd better examine how it works. Look at this short command file:

```
ERASE
@ 12,30 SAY 'File to use' ACCEPT
TO filename
USE &filename
RETURN
```

It's fairly obvious what's happening here. The program asks for a filename and stores it in a memory variable called 'filename'. The next line is a standard USE command, except that the variable filename crops up, preceded by an ampersand (&).

Whenever dBase comes across an ampersand, it replaces the variable name that follows with the value of that variable. This is purely a textual substitution; therefore the variable must be of string type, and the result will be evaluated purely as a string.

This can lead to some confusion. For example:

```
STORE '3' TO var1
STORE '4' TO var2
? &var1 + &var2
7
? &var1&var2
```

```
34
? '&var1' + '&var2' 34
```

As a result, code that makes extensive use of macros can be very confusing indeed. However, it is possible to do things that would otherwise be impossible, such as writing self-modifying code, or abbreviated menu routines: WAIT for a menu selection and then DO &choice.

Here is an example of a simple menu program using a macro:

```
* MACMENU.CMD by LGB
* Illustrates use of macros for menu
operation
ERASE
DO WHILE T
  @ 5,12 SAY 'Add Names'
  @ 6,12 SAY 'Delete Names'
  @ 7,12 SAY 'Quit'
  @ 21,12 SAY 'Choice'
  SET CONSOLE OFF
  WAIT TO Choice
  SET CONSOLE ON
  STORE !(choice) TO choice
  IF @(choice,'ADQ') = 0
    ? chr(7)
  ELSE
    DO SUB&choice
  ENDF
```

# Getting the best from dBase

```
ENDDO
RETURN
```

## More Uses For Macros

Other uses for macros include cramming as much as possible into dBase lines by replacing complex functions with macros:

```
STORE 'STORE $(disdate,7,2)+$(dis-
date,4,2)+$disdate,1,2) TO mdate'
TO makedate
```

```
other code
```

```
&makedate
```

However, the primary application for the macro function is with the USE and FIND statements. For example, the code segment:

```
STORE 'Smith' TO name
FIND name
```

will not work, since dBase will literally search for 'Mr. name'. Instead, use this technique:

```
STORE 'Smith' TO name
FIND &name
```

A similar technique is used with the USE statement.

## Guidelines

Macros are invaluable; as we have seen, the FIND and USE commands can hardly be used inside programs without them. At the same time, they make debugging much more difficult, since they literally change the text of the program source code itself. For that reason alone, I am not suggesting some of the more arcane uses of macros. If you are sufficiently perverse, you will no doubt be able to come up with delightful mind-bogglers of your own.

In the interests of retaining your sanity, there are a few guidelines you should bear in mind when using macros.

First of all, consider the operation of dBase itself. Execution of program statements is a two (or more) step process. First of all, the macro pre-processor scans across the line, looking for ampersands. If it finds one, it then extracts the following variable name and replaces the ampersand and variable name with

the contents of the variable.

If it finds a second ampersand before the variable name, it will evaluate that macro first, and then return to perform a second pass. For the technically minded, the macro pre-processor appears to be recursive. In other words, it keeps re-scanning the line until it has removed the ampersands. Finally, after all ampersands have been removed, the resulting line is actually executed by the dBase interpreter.

Rule One: the resulting text line must still be standard ASCII text, therefore **any variables used for macro substitution must be of type Character**. If you want to insert a number, presently stored in a variable, into a command line, you must first convert it into a character variable using the STR function. Failure to do this, or any attempts to use numeric variables in macro substitution, will crash earlier versions of dBase or result in an error message in 2.4.

Rule Two: **the resulting text line must still obey the rules of the dBase language**. For example, you cannot use macro substitution to produce variable names longer than ten characters. If in doubt, test it on paper first: do the macro substitution and see if the resulting statement is legal dBase code.

Rule Three: **you cannot use database fields for macro substitution**. They are different animals from memory variables, remember.

Rule Four: **macro substitution takes place anywhere in a dBase program**, including inside quoted text or string constants. For example:

```
STORE 'Surname' TO indname
```

```
? 'The current index is &indname'
will work. This is sometimes a useful
side-effect, but usually there is a
more conventional and understandable
way to get the same result. For
example:
```

```
STORE 'Surname' TO indname
? 'The current index is ' + ind-
name
```

will also work, and is more understandable to programmers familiar with BASIC but not dBase. It's probably faster, as well.

Rule Five: **Macro substitution takes place up to another ampersand, a space, a line end, or an operator.**

This can be used to form filenames out of two concatenated parts.

These simple guidelines will help to keep you straight in using macros. Another problem to watch out for is the mysterious error message or correction message. For example, in your code, you might have something like:

```
STORE '1' TO fred
STORE 'fred' TO varname
```

```
STORE &varname + 1 TO &var-
name
```

When this runs, you'll get an error message, since variable 'fred' contains '1', and you can't increment a string. However, the 'Correct and retry?' string will be

```
STORE fred + 1 TO fred
```

Don't go looking through your code for that line, as it doesn't exist; it's the result of the macro substitution that the interpreter is telling you is wrong. This kind of thing can make debugging your program a nightmare.

## dBase functions

dBase has a selection of functions which return values after performing some operation.

# – record number function – this returns the number of the current record at which the database is positioned. After an unsuccessful find, this is zero (with TALK SET OFF, this is the only way you'll know that no match was found).

\* – deleted record function – returns true or false, depending on whether the current record has been deleted or not. Remember that each record in a .DBF file has a single byte at the beginning which contains an asterisk if that record has been deleted.

EOF – end of file – returns true if you try to read beyond the end of a file. Used to control DO WHILE loops.

!() – upper case conversion function – converts the variable or string literal in the brackets to upper case. Thus !(Hello World!) is 'HELLO WORLD!'.

## REPRINTED LISTINGS FROM DBASE TUTORIAL, APRIL 1984

### Listing 1

```
ERASE
? 'Hello World'
```

### Listing 3

```
STORE 1 TO control
DO WHILE control < 11
  * main body of loop
  ? control
  STORE control + 1 TO control
ENDDO
```

### Listing 4

```
GO TOP
DO WHILE .NOT. EOF
  * main body of loop
  SKIP
ENDDO
```

### Listing 6

```
IF mgross < 0
  tax = 0
ELSE
  tax = mgross * 0.46
ENDIF
```

### Listing 7

```
DO CASE
  CASE expression1
    statements
  CASE expression2
    statements
  CASE expression3
    statements
  OTHERWISE
    statements
ENDCASE
```

### Listing 9

```
SET TALK OFF
USE bkinv
SET FORMAT TO PRINT
SET MARGIN TO 0
DO WHILE .NOT. EOF
  STORE 0 TO count
  DO WHILE count < 10 .AND. .NOT. EOF
    STORE count * 6 TO pagepos
    @ pagepos+0, 0 SAY "Stock Number:"
    @ pagepos+0,14 SAY stockno
    @ pagepos+1, 0 SAY "Title:"
    @ pagepos+1, 8 SAY title
    @ pagepos+2, 0 SAY "Author:"
    @ pagepos+2, 8 SAY author
    @ pagepos+3, 0 SAY "Publisher:"
    @ pagepos+3,11 SAY publisher
    @ pagepos+3,27 SAY "Sell Price:"
    @ pagepos+3,39 SAY sell:price
    @ pagepos+3,53 SAY "Buy Price"
    @ pagepos+3,64 SAY buy:price
    @ pagepos+4, 0 SAY "Stock on Hand:"
    @ pagepos+4,15 SAY stock
    @ pagepos+4,27 SAY "Back Ordered"
    @ pagepos+4,41 SAY backorder
    @ pagepos+4,53 SAY "Reorder Level"
    @ pagepos+4,68 SAY reorder
    @ pagepos+5,30 SAY "-----"
    SKIP
    STORE count+1 TO count
  ENDDO
ENDDO
SET FORMAT TO SCREEN
```

### Listing 2

```
world:
  proc options(main);

  put skip list (ascii(26),
  'Hello World');

end world;
```

### Listing 5

```
IF zot > foobar
  range = zot - foobar
ENDIF
```

### Listing 8

```
ERASE
DO WHILE t
  @ 5,12 SAY 'Add Names'
  @ 6,12 SAY 'Delete Names'
  @ 7,12 SAY 'Quit'
  @ 21,12 SAY 'Choice'
  SET CONSOLE OFF
  WAIT TO mchoice
  SET CONSOLE ON
  mchoice = !(mchoice)
  DO CASE
    CASE mchoice = 'A'
      DO addnam
    CASE mchoice = 'B'
      DO delnam
    CASE mchoice = 'Q'
      ERASE
      CANCEL
    OTHERWISE
      ? CHR(7)
  ENDCASE
ENDDO
```

TYPE() – returns the type of variable or expression in the parentheses. Either C, N, L or U will be returned, indicating character, numeric, logical or undefined.

INT() – integer function – takes the integer part of the variable in the brackets.

VAL() – string to integer conversion – notice that it only returns an integer value, with no fractional part.

STR(n,l,p) – numeric to string conversion – converts numeric variable n to a string of length l, with (optionally) p places after the decimal point.

LEN() – string length

\$(s,p,l) – substring extraction – extracts l characters from string s starting at position p. For example, \$('ABCDEFG',4,2) is 'DE'.

@(s1,s2) – string search – returns the position of string s1 in string s2. Thus @( 'CD', 'ABCDE' ) is 3.

CHR() – ASCII character. This works just like CHR\$ in BASIC. Thus CHR(65) is 'A', while CHR(27) is the ESCAPE character.

RANK() – decimal value of character. This is the reverse of CHR, since it returns the position of the character in the ASCII sequence. Thus RANK('C') is 67.

FILE() – Does file exist? WARNING!!! DO NOT USE while any database (.DBF) file is open, as dBase will erase a number of files from your disk; usually the database file and any associated indexes, but often a number of others for good measure. If you still feel safe using this function, it returns .T. or .F.; for example:

```
IF FILE('BKINV.DBF')
  USE BKINV
ENDIF
```

TRIM() – eliminates trailing blanks – because dBase fields are of fixed length, they will often have extra padding spaces on the end of the contents. TRIM gets rid of these blanks; for example:

```
? TRIM(town) + ' ' + TRIM(state) +
  ' + postcode
```

Next month, we'll start by looking at @...SAY...GET statements and format files, and then look at some real programs. □

# Dick Smith

# COMPUTER CITY

## For range and value, we can't be beaten!

Come on in to Dick Smith Electronics COMPUTER CITY for the very best!

You'll find a computer to suit your needs - from the beginner to the business user ... and everything in between.

You'll find friendly, helpful staff - experts in their fields. They'll be able to answer your questions with authority and accuracy.

You'll find our computers on display - working - where you can try them out. Nothing beats actual 'hands on' experience.

But most of all, you'll find the reassurance of dealing with Australia's leading computer retailer - 50,000 owners can't be wrong - with the technical back-up, the service back-up and the software back-up that the department stores simply can't match.

Trust Dick Smith Electronics COMPUTER CITY for YOUR computer.

### The Challenger

The IBM PC compatible that beats the IBM ... on price, on performance, on features, on expandability ... on everything!

The Challenger is the computer for the small to medium size business (it has 10 times the memory of Dick Smith Electronics first mainframe computer!)

But it's more than that: because it is compatible with IBM PC software and hardware, it makes a superb scientific or industrial computer ... or even a low-cost IBM terminal. And you'll save a fortune!

### The CAT

Why waste hundreds of dollars buying an Apple computer when you can buy The Cat ... Dick Smith Electronics' latest computer masterpiece! It's twice as fast as the Apple IIe. It has a bigger and better BASIC. A larger keyboard. Super hi-res colour graphics. More sound channels. Just compare the two computers and judge for yourself! (Ask for our free comparison brochure).

Compatible with most Apple IIe software, The Cat is THE computer for education, for the student at home, for the hobbyist, for dedicated functions in industry ... even for the small business.

As Electronics Australia Magazine says 'Dick Smith Electronics has come up with a winner with the CAT personal computer'.

### VZ-200

The ideal computer for the beginner who wants a computer to grow with: Dick Smith Electronics incredible VZ-200. It's the low-cost way to go computing - without buying an 'orphan' or dumped computer with no back-up.

The VZ-200 has a great range of low-cost software from games to small business utilities. And it's also very popular with amateur radio operators because of its very low noise level.

If you're starting out, you'll start out best with a VZ-200.



## THE NEW DICK SMITH CHALLENGER

### System Unit

The 'works' of the computer ... keyboard, CPU, 128K RAM, input/output ports, etc. Ideal for cassette-based applications as it is with nothing more to buy. Includes Centronics parallel printer port, cassette port, joystick & light pen ports plus RF, video and RGB outputs.

Cat X-8600 All this for only ...

# \$995

### Expansion Unit

Far more than mere expansion!

As well as three IBM compatible expansion slots plus two true 16-bit slots, you get twin slimline disk drives and an RS-232C communications port.

### PLUS free software!

We also include a range of quality software worth over \$1800 ...

Microsoft MS-DOS & GW Disk BASIC, Perfect Writer, Perfect Filer and Perfect Calc PLUS user manuals! Cat X-8610 Expansion unit and software ...

# \$1995

This makes the Challenger more than a match to the IBM PC - much more. Yet the IBM PC expanded to this level costs well over \$7000. Compare the Challenger - and Save!

**TOTAL SYSTEM ONLY ... \$2990**  
YOU SAVE OVER \$4000 ON THE IBM PC!!!

# Electronics



Apple IIe compatibility . . . but half the price! That's The CAT.  
It's the best of both worlds: the very latest and most powerful hardware, plus the ability to run a very broad range of tried-and-proven software.

And because we import direct, there's no middleman to force up the price. It really is outstanding value for money. Again from EA: "If you want a machine which is compatible with the Apple II and which is supported by a reputable dealer, the CAT with emulator is good value". Check the CAT out at your nearest Dick Smith Computer City. It purrs.

Cat X-7500

**\$699**

That's far less than half the price of the Apple with similar features!

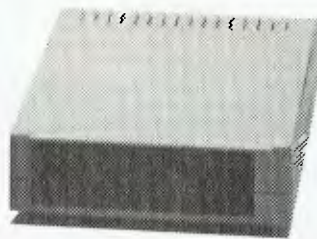

**NEW!**



**OVER 19,000  
ALREADY SOLD!**

## VZ-200 Computer Package

Our already great value VZ-200 is now even better! We've put together a package of the 'most asked for' bits and pieces - and slashed the price! Yes, you can still buy a VZ-200 without the extras for only \$169 (Reduced from \$199!) but take a look at what else you get . . .

- **VZ-200 COLOUR COMPUTER** USUALLY  
**\$169<sup>00</sup>**  
Complete with USER manual, BASIC manual & Demonstration Cassette. Ready to plug into your TV set. Cat X-7200
- **DATASETTE** **\$69<sup>50</sup>**  
Specially designed recorder for loading and saving programs. Cat X-7207
- **16K RAM EXPANSION MODULE** **\$79<sup>00</sup>**  
Expands your memory to 24K which is essential for serious programming. Cat X-7205
- **INTRODUCTION TO COMPUTER BOOK** **\$9<sup>95</sup>**  
A step by step guide to using your new VZ-200 computer. Cat B-7200
- **6 PROGRAMS** **\$75<sup>00</sup>**  
A selection of ANY 6 software tapes normally \$12.50 each. (X-7241 Learjet or X-7249 Air Traffic Control not included)

**TOTAL PRICE USUALLY \$402** **\$299**  
Package price

### SAVE even more!

Need a printer? We'll throw in one of our fantastic 4 colour printer/plotters and a printer interface for just \$200 extra! Normally these items sell for over \$270 . . . so multiply your savings on the VZ-200 total package!

**DICK SMITH ELECTRONICS**  
Stores throughout Australia 

Head Office and Mail Order Centre: PO Box 321 North Ryde 2113. Tel.(02) 888 3200.



# MicroProfessor

## MPF-III

TRADE MARK

The latest technology in 64K microcomputers dual processors  
— 6502 and optional Z80 card, run Apple IIe and CP/M software.

• SMALL BUSINESS • • EDUCATION • • HOME • • HOBBY •

### STANDARD FEATURES

- Runs 8 languages
- Upper and lower case
- Detachable keyboard with 90 keys
- 40/80 column (keyboard selectable)
- Centronics printer interface
- 38 tone sound generation chip
- Powerful editing features
- 4 additional expansion slots
- One key basic command entry
- 12 programmable function keys
- Numeric keypad
- RF modulator
- Cassette interface
- High and low resolution colour graphics
- 64K, RAM 24K ROM
- Comprehensive operation manual

**3 MONTHS FULL WARRANTY**  
**COMPLETE BACK UP OF SPARES**  
**AND SERVICE FACILITIES**  
**GUARANTEED BY EMONA FOR**  
**A MINIMUM OF THREE YEARS**

**Comprehensive Operational Manual**  
**and Programming Manual supplied**  
**with each computer; plus Optional**  
**Reference Manual available.**

Hundreds of software programmes are  
readily available with a broad range of  
applications from business to  
entertainment.



**SAVE \$\$\$**  
ON SPECIAL PACKAGE OFFERS

Example:  
**STAGE 1 PACKAGE**  
Recommended Prices:

MPF III	\$699*
AGC Green Monitor	\$154*
Disk Drive	\$328*
Drive Interface	\$59*
280 Card	\$59*
<b>Total Value</b>	<b>\$1299</b>

**ALL FOR ONLY**

**\$1168\***  
**SAVE \$130**

CONTACT EMONA OR YOUR LOCAL  
DEALER FOR SPECIAL PRICES ON  
THE STAGE 2 PACKAGE



ACT Winchester & networking available.

## EMTEK EX-80



**Printer Bargain**

**\$290\***

- 80 characters sec
- Dot matrix
- Bit image graphics
- Bi-directional
- Single sheet or continuous Tractor Feed
- Centronics parallel interface (serial interface optional)
- Graphics

### Print Types

- † Enlarged
- † Italic
- † Compressed
- † Underlining
- † Double Strike
- † Sub script
- † Superscript

## AGC HM-123



**GREEN**  
**\$154**

**AMBER**  
**\$156\***

- 360° Swivel display
- Super high resolution
- Crisp 80 chr. display
- Non-reflective screen
- Resolution: 1000 lines
- 22 MHz band width
- F.C.C. Class B approved
- Attractive styling

## SAKATA SP 1000

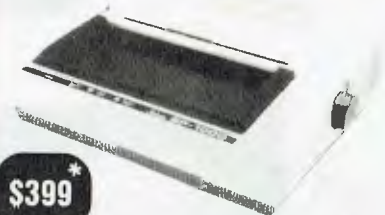

**\$399\***

For the office the Sakate SP-1000 offers 100 CPS speed as well as the features below to make your office application more efficient.

- Clearly formed dot matrix characters — 9-11 dots
- 12 variations of character printing within the same line including graphic printing
- Paper cutting edge 2cm from printing position
- Print on fanfold, single sheet and roll paper
- Back feeding of paper
- Bi-directional printing
- Operator replaceable print head (no special tools required)
- Longer ribbon life (2.5 million characters)
- Centronics parallel and RS-232C Serial interfaces both included.



**EMONA COMPUTERS PTY LTD**

"THE TECHNOLOGY HOUSE"

National Australia Bank Bldg,  
2nd Floor, 661 George St., Sydney, N.S.W.  
Ph: (02) 212 4815 or 212 3463 Tlx: 74500

ALSO AVAILABLE FROM:

VIC Radio Parts Group 329 7888

Advanced Technology Computers, 233 9733

ACT Electronic Components P.L 80 4654

SA International Communications Systems P.L 47 3688

TAS George Harvey Electronics, Hobart, 34-2233

George Harvey Electronics, Launceston, 31-6533

QLD Baltec Systems 369 5400

Genuine dealer enquiries welcome.

\*(Add 20% to all prices if applicable)

bankcard

welcome here

MICROPROCESSOR REG. TRADEMARK OF MULTITECH INDUSTRIAL CORP. APPLE Reg. Trade Mark of APPLE Computers Inc.

CP/M Reg. Trade Mark of Digital Research Inc.

Prices shown are for N.S.W. Additional transport charges may be involved for other states.

*An 80 cps dot matrix printer that works as well as the Epson MX80 or the C.Itoh Prowriter yet costs far less? Bet you thought it would never happen. Neither did Ken Ozanne, but he's a converted user of the Amust DT80 now.*

# Amust DT80



Egyptian hieroglyphics produced on the Amust DT80.

AT LAST, it is now possible to buy a dot matrix printer in Australia at a price not too much higher than those we read about in the American magazines. The Amust costs \$275 (plus tax) from Micro-Educational (prices vary a little elsewhere). I bought mine with the Automatic ICE Apple/Centronics parallel card priced at \$90 plus tax, also from Micro-Educational. This card is Australian-designed and built and should be available from any Apple dealer.

My computers are both Apples, and the ICE card is an Apple card. You should be able to connect the Amust printer to any computer with a Centronics parallel output, but you may find it hard to match the ICE card's performance. I'm told there is also an RS232C option. I haven't seen it so I can't comment.

My order was sent on Tuesday (priority paid), and my printer arrived during the day on Thursday of the

same week. Since Micro-Educational is located in the Garden Suburb of Newcastle and I live in the Blue Mountains, that service would take some beating.

The printer is about the same size as an Epson MX80 or a C.Itoh 8510A Prowriter. It also has capabilities that are broadly comparable to either. It prints 7 by 8 characters in an 8 by 9 matrix field. There are two on-board fonts, normal and italic; either font can be printed in normal, compressed, enlarged or enlarged-compressed forms. There are also emphasised and double-strike printing modes, but these are not available in all combinations.

In normal or emphasised mode, the printer is capable of writing 80 columns on a standard A4 page. In condensed mode this rises to 142 columns. It is halved to 71 for enlarged-compressed characters and reduced to 40 for enlarged ones.

The Amust printer can also write subscripts or superscripts or underline in any mode. This range of printing features does not include proportional spacing as on the Prowriter, but otherwise the Amust seems fully as capable as Epson or C.Itoh. The Prowriter also has an advantage in printing 100 characters per second, as compared with 80 characters per second on an Amust or an Epson. (There is now an upgraded Epson which is also faster than the Amust.)

Apparently, the Amust uses the same ribbon cartridge as the Epson MX 80. (Please check this before you rush out to buy any.)

The printer comes with a 48-page book of instructions printed in Japan but almost totally free of 'Janglish'. It is really quite easy to follow, but the information is tightly packed. Don't expect to master all the printer's capabilities in the first hour! This book calls the printer a 'Micro

# Amust DT80

Graphic', which may help when you see overseas reviews.

## Control Sequences

Altogether, there are over sixty control sequences to which the printer can respond. Moreover, many of them can be used in combination. It is clearly not possible to do more than hit the high points in a short review. There are also a dozen micro switches, but most of the functions obtainable by moving switches are also available from software.

It is possible to specify form lengths absolutely (in inches) or in terms of number of lines to be printed. Since you have control of the movement on a linefeed to within 1/216 of an inch (about a tenth of a millimetre), it can take some time to set things up just so. But who wouldn't want to have the capability? It is always possible to accept the default settings and not mess with any of this. However, since the default page length is eleven inches and A4 is almost twelve, it is probably desirable to, at least, reset page length.

It is possible to set up to 28 tabs across the page and re-define them, under software control, at any time. I suppose you could re-define half-way through a line if you really needed more than 28. I've never used more than about ten and am not likely to test this.

The card documentation is not very well printed; in fact, I received a one-page summary to begin with and, only later, an eight-page booklet. However, even the one page version was quite usable and the eight-page booklet reasonably complete. It could be extended further, however – no Apple novice could be confident installing the card correctly from the given instructions: "Insert the printer card in Slot 1". Enough said.

## Typestyles

Although the Amust has specifications very similar to those of an MX80FT (graphics version of the Epson), the fonts are not similar. My impression is that all the print is just a little smaller. But the main impression is that the print is much more solid. I've been showing off the Amust to all and sundry and everyone has thought

the print quality remarkably good. (I haven't had a fabric ribbon yet, so some of it may be in the carbon ribbon.) But the carbon ribbon isn't the reason there are true descenders, for instance.

Like the Prowriter, and like the more fully built-up versions of the Epson, the Amust can work with either tractor or friction feed. This is standard, not an extra-priced option. I have used an Epson only with tractor feed, but the Amust friction feed is almost as good as the C.ltoh and very easy to use. It is, of course, quite essential to have friction feed to use the printer on standard paper, particularly letterhead paper.

The Amust has a number of graphics characters as well as its fonts (corresponding to non-printing characters not used for control purposes by the printer). These are neither as many, nor as useful, as the Katakana and Greek characters available on the C.ltoh. However, the capability of printing bit-image graphics means that any definable character set can actually be printed. I have experimented with mathematical fonts and with Egyptian hieroglyphics and have been more than happy with the results in each case.

Full use of bit-image graphics demands appropriate software to control the printer. This is where the ICE card comes in – it has the capacity to dump an Apple high-resolution graphics page to the printer. There are commands to dump either high-resolution page, to dump in inverse, or a double page or a part page. You can even dump the two graphics pages side by side to make a larger picture. With care, you can dump more pairs of pictures to build up one large picture of indefinite size (using continuous paper, of course).

For this kind of work the superior ribbon of the Amust (there does not appear to be a carbon ribbon available for the C.ltoh) makes it a little preferable to the Prowriter. It is a good deal better than the Epson.

However, the ICE card has the same abilities as the Prowriter, and the availability of ribbons must surely be a temporary thing. Nevertheless, the fact that the Amust has graphics as good as the Prowriter is impressive when it costs so much less.

## The ICE Card

The ICE card almost rates a separate review of its own. I used to use the New Zealand card distributed by Electronic Concepts with a Prowriter. That card costs nearly half as much again as the ICE card and has no smarts at all. The ICE can handle Apple, NEC, Star, Case, Microline, Prism and Seikosha graphics as well as those mentioned. In fact, those are just the ones for which direct graphics dumps are available on the standard ROM in the card. If you have another printer, I'm sure a special ROM is either already available or about to be (assuming your printer has a graphics capability, of course).

I am writing this review using Sandy's word processor. In printing out various drafts, I have noticed that printing eighty columns on the Amust appears to work rather like printing forty columns to the Apple screen – you get extra linefeeds. I expect there is an extra linefeed because printer, interface card and Sandy's are combining to outsmart one another. In the meantime I have just printed 79 columns wide and the problem has vanished.

One small caveat with the ICE card. The connector for the printer will only just barely fit through the largest slot (above the power supply) on the IIe. You really need to be told, because it very nearly doesn't. Of course, once in it doesn't have to be removed again, so the problem is not desperate. The card comes with a metre of cable, which seems a lot when you are unwinding it but is none too much on my cluttered workspace.

Another nice feature that belongs half and half to printer and card is that you can dump graphics in enhanced mode (double density). You get really impressive results (the Epson can do this, but the Prowriter can't).

Returning to the gripe list (still minor) ... my printer is brown. Not an objectionable colour in itself, but definitely not an Apple colour. I'm told there is now a beige version available, but I'm afraid Micro-Educational won't accept the colour as a reason for replacing mine. And nothing else is wrong with it.

# Only an Atari<sup>®</sup> Supercomputer<sup>™</sup> can give you all this...

- 16K Memory expandable to 64K
- International Character Set
- Over 1,000 ready-to-use programs
- Help Key
- Built-in Atari Basic Programming Language
- Complete range of plug-in Peripherals
- CP/M\*† Option
- 5 Programming Languages
- 29 Graphics Keys
- 11 Graphics Modes
- 5 Text Modes
- 256 Colours
- 4 Sound Voices
- And more

For only \$399<sup>RRP</sup>

## ATARI 600XL<sup>™</sup> Home Computer



**We'll show you the way**  
Available from leading Atari stockists



(®) & TM are trademarks of Atari Inc., or Futuretronics Australia Pty. Ltd. \*CP/M is a trademark of Digital Research Corp. † Tentative title.

CONCORD/8687

# NOW

# AVAILABLE

## GREAT ENTERTAINMENT PROGRAMS FOR SINCLAIR SPECTRUM



### HARRIER ATTACK (16K) \$19.95

Your Jet leaves the aircraft carrier for the enemy island to destroy the enemy and return before fuel runs out. A fight against the enemy, above & below, and fuel consumption. If fuel is gone, eject, save yourself!

### TRANSYLVANIAN TOWER (48K) \$19.95

Find your way up through the tower maze, kill Count Kreepie & get the map to raid his treasure trove. Kill the bats. The only way up is to kill enough, if you don't, then watch out!



### GENON (48K) \$19.95

Genon is paralysing the galactic system. The Cosmos is dying, drained of thought. The computer on Genon has all knowledge. Your ESP can fight Genon. Reach & decode the computer. Avoid Bogul.



## PLUS MANY MORE

3D TUNNEL (16K)	\$19.95
3D MONSTER MAZE (16K)	\$16.95
ESCAPE (16K)	\$16.95
KNOT IN 3D (48K)	\$19.95
SUPER SPY (48K)	\$19.95
EVEREST ASCENT (48K)	\$19.95
INVINCIBLE ISLAND (48K)	\$19.95
SHIP OF THE LINE (48K)	\$19.95
DEVILS OF THE DEEP (48K)	\$19.95
JUNGLE TROUBLE	\$19.95
SCUBA DIVE (48K)	\$19.95
3D DEFENDER (16K ZX81)	\$19.95

FROM YOUR LOCAL  
COMPUTER DEALER

# Ozi Soft

DEALER ENQUIRIES:  
SUITE 33, 8-24 KIPPAX STREET  
SURRY HILLS 2010. PH: 211 1266

Anyone experiencing problems with saving and loading cassettes for use on their Microbees, particularly at 1200 baud, may like to try the following suggestions from Daniel Ford, the Engineering Manager for Memory Products at Applied Technology.

# Microbee Cassette Interface Modification

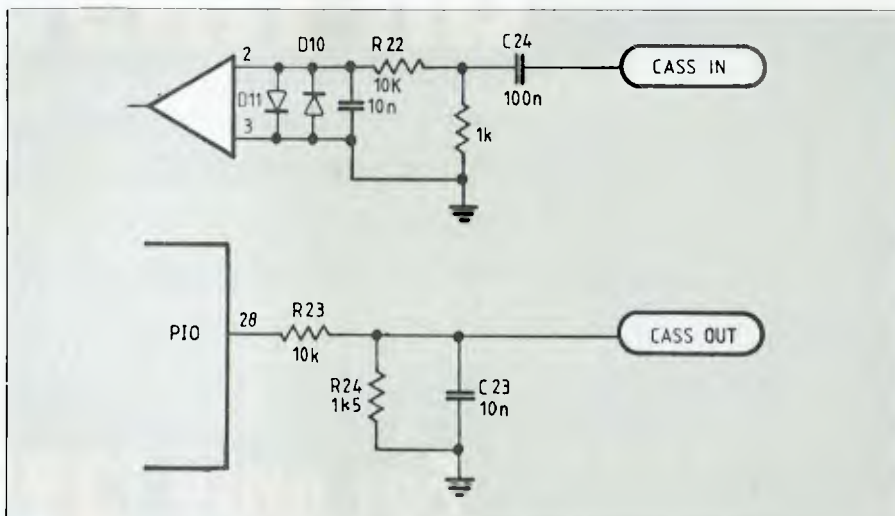

### 1. DC Load

Some cassette machines require a DC (resistive) load on the earphone output. If yours is one of these, fit a 100 ohm resistor across the earphone connection, preferably inside the recorder.

### 2. Azimuth

Problems can occur if you try to load 1200 baud cassettes which were recorded on a different machine. If you know your recorder works reliably at 1200 baud, but it will not load someone else's 1200 baud tape, it may be that the azimuth of the two recorders is different. Refer to Appendix B of the new Wordbee User Manual for details of azimuth adjustment. However, it may be necessary to readjust the azimuth, to be able to load your own 1200 baud tapes again.

### 3. Circuit Modification

The modifications shown in the diagram provide improved 1200 baud performance on many cassette recorders. They should be carried out by someone skilled in electronics work, or by Applied Technology (a small fee will be charged). With this modification, your optimum record/playback level will need to be re-established. For most low-cost cassette machines, a setting between a third and a half of maximum has been found to be satisfactory. □

### NOTES

1. R22, C24 positions reversed from original and extra 1k fitted from junction to ground; 10n fitted across D10/11.
2. R23, R24, C23 values all different from original link in original C23 location. C23 .01 fitted to TP8/9. R24 track to +5 V cut and grounded.



# Who's keeping up with Commodore?

The Commodore EXECUTIVE 64.  
A personal, portable computer with outstanding graphics, colour, music and astonishing computing capability, all in an easy-to-carry case.

The Commodore EXECUTIVE



64 is designed for the movers of this world. Designed to give you the power. Power at your fingertips. The power of 64K memory. The power to keep up. In the office. At home. Or in your home away from home.

**commodore**  
COMPUTER  
Keeping up with you.

Commodore Business Machines Pty. Ltd.  
5 Orion Road, Lane Cove NSW. 2066. (02) 427 4888.  
Please send me more information on the Commodore Executive 64™

Name \_\_\_\_\_  
Address \_\_\_\_\_

BMS/CC 152 Postcode \_\_\_\_\_ Phone \_\_\_\_\_ V.C. \_\_\_\_\_



# The new Texas Instruments Professional Computer gives you more for the money.

"This is the machine IBM  
should have designed

It is the optimum  
personal computer."

Popular Computing  
October 83



# Tear and compare.

Compared to the leading competitors, the TI Professional Computer gives you more for the money. Tear out this chart and compare. TI offers you:	TEXAS INSTRUMENTS PROFESSIONAL COMPUTER	IBM	APPLE
Two additional programmable function keys (a total of 12) for simpler, easier use.	✓		
Software for virtually every professional and business need.	✓		
40-50% better monitor resolution for sharper displays (720 x 350 pixels).	✓		
Capability for graphics with 8 colours simultaneously instead of only 4, and no trade-off in resolution quality.	✓		
Three times more information on your screen when using graphics and text. (Superimpose graphics and text.)	✓		
Eight monochrome levels of brightness for more detailed monochrome graphics and text.	✓		
Separate numeric keypad, cursor control, and edit/delete keys for easy use and less chance of accidental data loss.	✓		
Superior expansion and future enhancement capabilities to prevent instant obsolescence.	✓		
Flexible upgradability to Internal Winchester disk drive with no modifications to hardware.	✓		
The ability to run the same software on the colour or monochrome monitor.	✓		
True multiuser capability via local area network.	✓		
Speech command capability.	✓		

When you're comparing personal computers, look carefully for the 12 features in the chart above.

And when you compare price, look for the fine print. Do the others give you 320K floppy disk storage and an internal printer interface? Do they give you a display unit? Do you get the keyboard features, the memory, the expandability, or the future capability that TI offers?

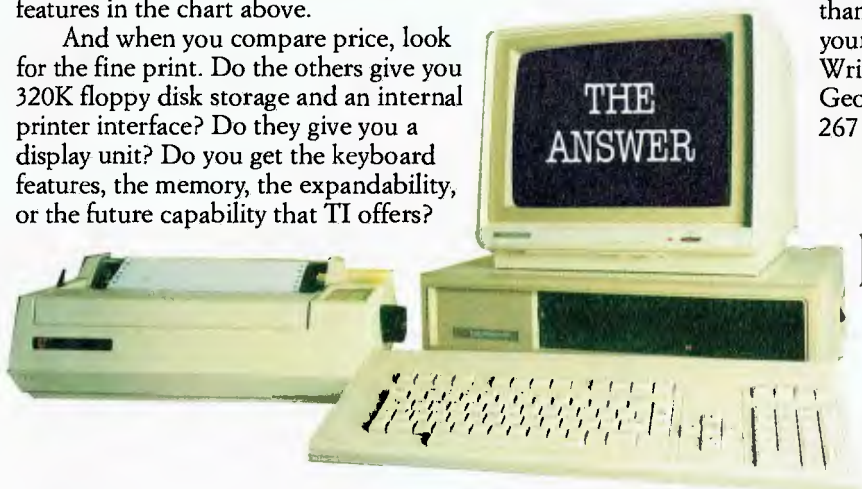

The TI Professional Computer gives you more productivity power than any leading competitor. Visit your nearest TI dealer or call Jim Wright (Sydney) 887 1122 or Geoff Hipwell (Melbourne) 267 4677.

**TEXAS INSTRUMENTS**

Creating Useful Products and Services For You



# DAVONG DELIVERS WHAT EVERY APPLE, IBM, OR OSBORNE USER WANTS.



*More*



Available from all fine  
Micro Computer Dealers.

## **MORE disk storage**

Expand the disk storage of your Apple II\*, Apple III\*, IBM Personal Computer\*, Osborne 1 Computer™ — up to 60 megabytes of fast, reliable Winchester data storage.

## **MORE value**

Davong 5, 10 and 15 megabyte systems are priced at only \$2880, \$3799 and \$4348 (ex tax). Adding additional Davong slave drives costs even less. Everything you need is included. And because the Davong system is universal, your disk investment is preserved, even if you change to a different personal computer.

## **MORE software**

The Davong system includes all the software you need to start right away. And Davong's new Multi-OS™ supports all Apple and IBM PC operating systems.

The Davong Multi-OS operating system gives your computer full multitasking network capability. Complete software support includes back-up and restore programmes.

## **MORE backup options**

Davong offers a choice of 18Mb cartridge tape backup or 5Mb removable cartridge disk backup, at extremely attractive prices.

## **MORE support**

Additional 9 months warranty available.

## **MORE of what you bought your personal computer for**

Better performance, higher reliability, the best value — hard disk storage from Davong.

The Davong Universal Hard Disk also supports most IBM PC- and Apple-compatible computers.

Apple II and Apple III are registered trademarks of Apple Computer Corporation. IBM PC is a registered trademark of IBM Corporation.

Osborne 1 is a trademark of Osborne Computer Corporation.

Multi-OS is a trademark of Davong Systems Inc.



*Jeff Richards' tutorial this month deals with handling random access variable-length records in BASIC-80. The example uses a technique of multiple contiguous records per item with a bit-map free list to permit identification of suitable free contiguous records.*

# Getting friendly with BASIC

## Part VI

VARIABLE-LENGTH random access records are not directly supported in Microsoft BASIC-80. Applications that require variable-length records must be implemented using specially constructed routines.

Variable-length records are most applicable when dealing with alpha-numeric data. A message-taking system, for instance, could be asked to cope with messages ranging from a few words to half a page of text, or more. If each record is established to allow for the maximum likely length of message, a great deal of file space will be wasted. Alternatively, if the space allowed per record is too small then important information may have to be left out. Flexibility of record size, efficiency of storage and random access seem to be incompatible design goals.

A number of techniques are available to deal with variable-length items. The usual procedure is to define a record size less than the required size of the data item, and then allocate a number of records for storing the item. The item to be stored is broken into as many segments as necessary, each segment being stored in one record. A record size as small as one byte can be used, though it is more common to select a record size that will result in between two and ten records being needed for each data item.

In all cases one problem to be dealt with is how to advise the system of the number of records that have been used to store an item, so

that the whole item can be quickly and conveniently retrieved. If the record allocation method does not implicitly identify the number of records used to store the item, then this information must be inserted into the record before it is written to the file.

One of the simplest methods is to spread the items to be stored amongst a number of files, each with a different record size. An item is stored in the file that has a record size just larger than that needed to accommodate the item. As BASIC-80 allocates only the amount of space necessary for a file, this technique can be quite efficient in storage space. The drawback is the number of files that must be open at one time, unless a great deal of time is wasted in opening and closing files.

A more serious drawback is the added complexity in the index for such a system. Instead of simply pointing to a record, the index must indicate in which of the possible files the item is stored.

### Varying The Technique

A slight variation in this technique uses only one file, but divides it into areas for storage of different-sized items. These areas are called partitions, and within each partition a fixed number of records will be used to store each item. For example, the partition consisting of records 1 to 100 might be allocated to two-record items, 101 to 220 for three-record items, and so on. A simple memory

table can be used to determine both the partition in the file that an item of a particular length should be stored, and the length of an item that has been stored at a particular record number.

Note that a separate free list will be needed for each partition, and the memory table should be organised to indicate what are valid storage locations within a partition. For example, if records 101 to 220 are allocated to the three-record partition only record numbers 101, 104, 107 and so on would be valid storage locations, and only these records would be included in a free list. Without this information about valid record numbers sequential access to the file, for example in order to rebuild the index, would be difficult or impossible.

A partitioned file is simple to maintain and quick to use, but it has the drawback of inflexibility. If the relative numbers of different-length items is known, then the sizes of the partitions can be established with confidence. But if the distribution is not known, some partitions can become full while others still have ample room. When one partition becomes full then the file is effectively full, even though there is actually unused room in other partitions.

Partitions can be rearranged, but it is just this sort of reorganisation of the file that we have been trying to avoid. Nonetheless, for systems where the distribution of record sizes can be predicted with accuracy, ▶

# Getting friendly with BASIC

partitioned files can be easy and efficient.

The alternative to a partitioned file is to allocate records from the free list as demanded by the different-length items, and to note within the data item the number of records that are to be read in order to retrieve the complete item. Two basic methods are employed – one requires that records allocated to an item be contiguous while the other does not.

If records can be allocated contiguously then the only information we need to store in order to ensure correct retrieval of the item is the number of records involved.

## Drawbacks

The drawbacks of this scheme should be obvious. Firstly, the free record table has to be constructed in such a way that makes it easy to find a region with the required number of contiguous free records. The linked free list we have been using so far is clearly not suitable.

The second difficulty is that as records are deleted and added over time, small unusable free areas may develop. It could well happen that there is free room in the file, but none of it in areas of sufficient size to permit data items to be stored. Again, reorganisation may be needed in order to extract maximum room from the file.

The second approach avoids this, but has problems of its own. In this scheme the records that constitute a data item do not have to be contiguous but are linked together by a pointer from each record to the next, with a pointer of zero indicating the end of the data item. Data items can use as many records as needed, and the arrangement of free areas in the file is irrelevant. If deleted items leave single, isolated records they can be used as easily as contiguous blocks of records.

Some drawbacks of this approach are clear. Firstly, retrieval of data items may be slowed considerably if the item is stored in records that are scattered around the disk. Secondly, building the linked list of records that together constitute a data item adds somewhat to the complexity of data storage and retrieval. And thirdly, if the pointers are corrupted it is almost

impossible to recover the data in the file.

The example presented here will use contiguous fixed-length records to store the variable-length data items. The number of records needed to store the item can be inserted in the first record immediately after the key. Note that this technique should not be used with a record size that is smaller than the minimum size of an item to be stored. If the record size is smaller than the minimum item size then single, unusable, empty records will gradually appear in the file, using up valuable space.

In order to identify free areas of a suitable size some alternative to the linked free list must be found. Note that although the linked free list will tend, initially, to link sequential records, there is nothing in the way that we are maintaining the list that helps to ensure this is the case after additions and deletions. The free list could wander all over the file, so it is unsuitable for determining contiguous blocks of free records.

The technique that will be used to maintain data on the free areas of the file is a bit map. This should be familiar to CP/M users, as it is the technique CP/M uses to identify free sectors on the disk. A bit map consists of a string of bits that bear a one-to-one relationship with the records in the file. If the bit is set to one the record is in use – if the bit is zero the record is available. The bits will be maintained in an integer array as eight bits per byte. This array will be stored at the beginning of the file, occupying as many records as are needed.

As an example, consider a file of 500 records, each 32 bytes long. A bit map of 500 bits or 63 bytes will be needed for a file of this size. An integer array of 63 bytes needs 126 bytes of disk storage, so the first four records will be allocated to the bit map. These four records, as well as record 0 which does not exist, have to be flagged as 'not free'. For safety, records 501 to 511 have also been flagged as 'not free'. (As each integer will take on a value between 0 and 255, they could have been stored as characters in a string, thus halving the number of records required by the bit map. An integer

Listing 1. Write bitmap to disk.

```
10 REM INITIALIZE AND SAVE BITMAP
20 DEFINT A-Z
30 DEF FNA(X)=
  INT(F(INT(X/8))/2^(X MOD 8))
  MOD 2
31 DEF FNB(X)=INT(X/8)
32 DEF FNC(X)=F(FNB(X))-
  (FNA(X)=0)*2^(X MOD 8)
33 DEF FND(X)=F(FNB(X))+
  (FNA(X)=1)*2^(X MOD 8)
40 DIM F(64)
50 FOR I=0 TO 4:F(FNB(I))
  =FNC(I):NEXT I
60 FOR I=501 TO 511:F(FNB(I))
  =FNC(I):NEXT I
70 OPEN "R",#1,"MAST",32
80 FIELD #1,32 AS REC$
90 FOR I=0 TO 3
100 FOR J=0 TO 15
110 MID$(REC$,J*2,2)=MKI$
  (F(I*16+J))
120 NEXT J
130 PUT #1,I+1
140 NEXT I
150 CLOSE
```

array has been used for simplicity.)

Listing 1 is a program to initialise the bit map and store it in the first four records of the file.

To use the bit map in allocating items to records in the file, a number of routines will be needed, and these can be expressed as functions. FNA(x) will return the bit map value for record x – 0 indicating the record is free and 1 indicating that it is in use. Although it looks complex, it can be dissected into the essential parts. The array element is INT(x/8) because there are eight bits per byte. The bit position (x MOD 8) is just the remainder after dividing the record number by the number of bits per byte. The value of the array element is divided by two raised to the power of the bit position, and the result taken modulo 2 to return a 1 if the bit was set and a 0 if it was not set.

The second function (FNB(x)) simply returns the array position corresponding to the record number x. FNC(x) is used to set the bit and FND(x) is used to clear it. Both these functions actually return the new value of the array element – the element has to be updated in the program. The required statement is F(FNB(x)) = FNC(x) to set a bit and F(FNB(x)) = FND(x) to clear it – hence the need for FNB(x). The

Listing 2. Bitmap demonstration.

```

10 REM MAINTAIN BIT-MAP
FREE TABLE
20 DEFINT A-Z
30 DEF FNA(X) =
  INT(F(INT(X/8))
  /2^(X MOD 8)) MOD 2
31 DEF FNB(X)=INT(X/8)
32 DEF FNC(X)=F(FNB(X))-
(FNA(X)=0)*2^(X MOD 8)
33 DEF FND(X)=F(FNB(X))+
(FNA(X)=1)*2^(X MOD 8)
40 DIM F(64)
50 FOR I=0 TO 4:F(FNB(I))=FNC(I)
: NEXT I
60 FOR I=501 TO 511:F(FNB(I))
=FNC(I): NEXT I
70 GOTO 500
100 INPUT "FIND * FLAG *
UNFLAG ",I$
110 ON VAL(I$)+1 GOTO
100,200,300,400
120 GOTO 100
200 INPUT "Count = ",C
210 R=-1
220 COUNT=0
230 R=R+1
240 IF FNA(R)=1 GOTO 220
250 COUNT=COUNT+1
260 IF COUNT[C GOTO 230
270 R=R-C+1
280 PRINT"Found at ";R
290 GOTO 100
300 INPUT "Record number = ",R
310 INPUT "Count = ",C
320 FOR I=R TO R+C-1
330 F(FNB(I))=FNC(I)
340 NEXT I
350 GOTO 500
400 INPUT "Record number = ",R
410 INPUT "Count = ",C
420 FOR I=R TO R+C-1
430 F(FNB(I))=FND(I)
440 NEXT I
500 FOR J=0 TO 15
510 PRINT J*32,"";
520 FOR I=0 TO 31
530 PRINT STR$(FNA(I+J*32));
540 NEXT I
550 PRINT
560 NEXT J
570 GOTO 100

```

CARRIAGE  
RETURN

logical expressions in FNC and FND are to ensure that attempts to set a bit that is already set, or to unset a bit that is unset, will not corrupt the bit map.

Listing 2 is a demonstration program that incorporates all the basic functions. The bit map array is first initialised by setting the reserved records to 1. The three routines are search, set and reset. The search routine (200-280) uses the FNA function to find a contiguous region of  $r$  free records. The set routine (300-350) sets  $c$  contiguous bits starting at record  $r$ , and the reset routine (400-440) resets  $c$  contiguous bits starting at  $r$ .

The routine from 500 to 570 displays the bit map after each set or reset.

Using the bit map is almost the same as using the linked free list. Firstly, the number of records needed to store the item is calculated. If item length is  $t$  and record size is  $s$ , then the number of records needed is  $c = \text{int}(t/s + .99999)$ . The number of records required must be inserted into the item, so that the required number of records can be read when the item is subsequently accessed. The 'find' routine in listing 2 is used to find  $r$ , the record number at which  $c$  contiguous records exist. The item can be written to the  $c$  records from  $r$  to  $r+c-1$ , and the 'flag' routine used to identify the records as used. Finally, the key and the pointer ( $r$ ) are inserted into the index.

### Updating The Bit Map

To update the bit map when an item is to be deleted, the values of  $r$  and  $c$  are obtained from the index and the item, and the 'unflag' routine used to reset the bits in the bit map.

Unlike the linked free list, the bit map is not automatically updated on disk after each addition or deletion. Special provision must be made for writing the bit map back to disk at regular intervals, and certainly when the add/delete procedure is exited. Should the bit map become corrupted, it can be reconstructed by accessing each item from the index and noting the number of records that the item occupies. Those records are flagged as 'not free' while all others are flagged as 'free'.

Listing 3. Storing a record.

```

10 DEFINT A-Z
20 OPEN "R", #1,"MAST",32
.
.
50 FIELD #1, 32 AS BUFF$
.
.
160 S=32
170 T=LEN(REC$)
180 R$=STRING$(255,32)
190 LSET R$=REC$
200 C=INT(T/S+.99999)
210 R=-1
220 COUNT=0
230 R=R+1
240 IF FNA(R)=1 GOTO 220
250 COUNT=COUNT+1
260 IF COUNT[C GOTO 230
270 R=R-C+1
280 MID$(REC$,11,2)=MKI$(C)
290 FOR I=1 TO C
300 R1=R+I-1
310 I$=MID$(R$,I*32-31,32)
320 LSET BUFF$=I$
330 PUT #1,R1
340 F(FNB(R1))=FND(R1)
350 NEXT I
360 FOR I=0 TO 3
370 FOR J=0 TO 15
380 MID$(REC$,J*2,2)=MKI$(
(F(I*16+J)))
390 NEXT J
400 PUT #1,I+1
410 NEXT I

```

Listing 3 is the essential part of the add routine. A record length of 32 has been assumed, with a maximum item size of 255 characters. The item is first inserted into a string of spaces. Then the number of records needed ( $C$ ) is calculated and inserted into the item at position 11. A suitable record number ( $R$ ) is found from the bit map and the item is written to the file 32 bytes at a time. As each record is written the bit map is updated, and is finally written back to the file.

The final step would be to insert the key and the record number ( $R$ ) into the index.

The bit map has been presented here as a useful technique for maintaining a free list in a file used to store variable-length items. This is certainly not the only use for a bit map, but it is typical. Where the status of items can be expressed in a binary digit, the bit map is a speedy and convenient way of keeping track of those items.

Here begins an occasional series by Bill Bolton on how to get an RCPM system going. This first instalment tackles the hardware and software required.

# Starting an RCPM System

## Part 1

I HAVE been putting off doing a set of instructions for setting up an RCPM and interpreting the existing bits and pieces of documentation, because I couldn't see a clear plan for how to fit the notes together. Well, it's only a dim vision, but I now have some idea of how this might all be made to make sense – so hold onto your hats and lets 'goforit'.

### Some Assumptions

This is not meant to be an exhaustive tutorial on the subject, though it will go into some of the issues quite deeply. I am assuming that anyone who seriously wants to put up an RCPM system is either a fully fledged CP/M hacker (if you don't know what a hacker is ... you aren't one) or is very good friends with one. I am assuming a basic familiarity with most CP/M 'system' terminology and access to some of the major programs from the various user group collections.

I put up the first RCPM in Australia, with no documentation at all and a quick look at how Trevor Marshall's system and some of the US RCPM systems actually operated. These notes are a major advance in RCPM documentation and should make it much easier to get a system going.

### Non-CP/M Users

Don't despair if you are thinking of setting up a non-CP/M remote access system. Many of the issues discussed here will be of general interest to anyone considering a remote system on any computer. Peter MacGrath put together the OMEN RTRS systems software (which is largely original) from looking at RCPM systems and in response to a challenge from someone that he couldn't do it for a TRS-80 – anything is possible if you are prepared to try hard enough!

### The Computer

You need a computer that will run the CP/M-80 version 2.2 (or later) operating system. It need not be a Z80-based system; 8080 or 8085 CPU will do fine.

The computer should have I/O facilities for a console, printer and RS232-C serial communications. The printer facility isn't strictly necessary, but it is handy for security logging purposes. It is preferable that the USART used for the serial communications interface be easily programmable, including baud rate (for the future). The 2651 USART is probably the easiest to handle and the Zilog SIO/DART the hardest. The communications serial interface should also have some of the RS232-C handshaking lines implemented: usually two from the computer to the modem and two from the modem to the computer are adequate.

The computer should also have a real-time clock that is battery backed up. This isn't strictly necessary, but it makes security logging much more difficult if you don't have any idea when an 'event' happened.

The computer should have the highest possible disk capacity on its floppy disks. A good 20 cm disk system should give you almost 1.2 Megabytes per disk on double-sided disks. Even if you run a hard disk, you still need to back it up and floppies are the usual back-up medium – in view of the budgets most RCPMs seem to run on. It also helps if the disk controller can do DMA data transfers to minimise disk access waits, and if you power the drive motors down between calls, if not between disk accesses.

The terminal connected to the computer should preferably have a programmable status line. This allows the SYSOP to see instantly who is on the system, and (if you have a clock) how long they have been on.

The terminal should also have a bell or beeper that will respond to ASCII BEL characters. Apart from that you don't need anything very special for a terminal, unless you intend to use the same computer for general purpose things as well as an RCPM.

The printer doesn't need to be anything special either. It will only be used for logging what the remote user types into the system (not what the system sends). Again looking towards the future, the capability to keep up with short bursts of data typed in at 1200 bps would be desirable; but a slow printer with even a small internal buffer would probably handle that, anyway.

A desirable feature is a watchdog timer that will reset the system after a predetermined period of total inactivity (that is, no system polling or the like).

Of the current RCPM systems running in Australia, most are using IEEE-696 (S-100) bus hardware as it offers greatest flexibility. However, at least two are using single-board computers.

### The Modem

The modem must be a Telecom approved auto-answer modem. As RCPM systems have 'high' visibility with Telecom, it wouldn't even think of allowing a non-approved modem. Of the locally available CCITT V.21 standard auto-answer modems, only the DataSat World Modem and the Modem Technology UDM-1200 are being used on RCPM systems, though this doesn't mean modems from other manufacturers won't do the job.

When using V.21 modem standard on the Public Switched Telephone Network (PSTN), it should make little difference which end of a data conversation is in 'originate' mode and which end is in 'answer' mode. Conventionally, the answering part

uses answer mode. In practice, it *does* make a difference which end is which for some callers. With the Software Tools RCPM, about 20 to 30 per cent of callers find they get far fewer problems if they can change the RCPM to ORIGINATE mode and their end to ANSWER mode. This appears to be due to minor carrier imbalances on Telecom 'radio' paths.

In view of the 'real world' problems with modem modes, it may be advantageous to select a modem which allows control of the mode, usually through pin 11 (Select Transmit Frequency) of the RS232-C interface.

### The Software

The RCPM software has four parts:

1. A modified CP/M
2. The Communications Supervisor
3. The BASIC programs
4. The system utilities

### Modifications To CP/M

The modifications to CP/M are small. All the intrinsic commands must be removed from the CCP. These commands are DIR, ERA, REN, SAVE, USER. They are 'despatched' from a table in the CCP and the easiest way to eliminate them is to remove their entries from the command table. You will need to use DDT or SID on your CP/M system image to replace their entries in the command table with 00H bytes. As the location of the command table will vary between CP/M implementations, but is easily locatable as the command names are stored as ASCII text strings, I will assume you can fix this without further instructions (if you can't, you'd better reconsider the idea of running an RCPM).

The other modifications are optional. It is highly desirable that your RCPM system automatically restart itself if there has been a power failure. If you have your BIOS source code and can modify it, it is possible to get CP/M to execute a single command at cold boot time. This command for an RCPM system would be to load the communications supervisor and enable the modem for auto-answer operation. The details of the BIOS

changes are in the file CPMPATCH.ASM. You will need to embed the command you want executed on cold boots in the CCP; this is also detailed in CPMPATCH.ASM.

The other optional modification is to patch CP/M to automatically search for a command file on drive A.; if it can't find the file on the currently logged drive. This avoids having copies of commonly used programs, like HELP and BYE, on every disk of an RCPM system. The details of this modification are also in the CPMPATCH.ASM file.

### Communications Supervisor – Carrier Detect

The heart of any remote access system is the communications supervisor program. The Comms Supervisor role is to control the modem, monitor the data transaction for activity and provide basic transaction logging and control facilities.

The Comms Supervisor used with most RCPM systems is called BYE. It effectively makes the remote user the 'console' device for an RCPM system. The local console associated with RCPM systems is effectively connected in parallel with the remote user, so commands can be entered from either.

Telecom requires that any non-data caller to an auto-answer modem number be disconnected within 30 seconds. Auto-answer modems require pin 20 (Data Terminal Ready) of the RS232-C interface to be held active for the modem to be in auto-answer mode. If the DTR control line is taken inactive at any time, the modem goes into an 'off-line' condition, effectively 'hanging up'.

Let's examine what happens while the BYE program is waiting for a call. BYE has a 25-second countdown loop running at all times. When there is no call in progress, the loop times out every 25 seconds and forces the DTR modem control line to become inactive for a short time. When the phone starts ringing with an incoming call, the 25-second timeout loop is reset by every ring of the phone until the modem answers the call. This gives the caller a full 25 seconds to successfully 'connect'. The ring signal from the modem is available on pin

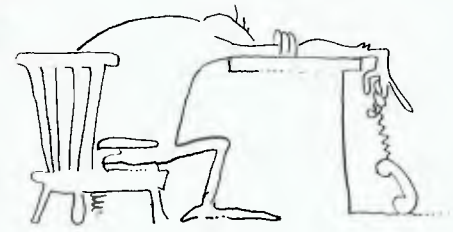

COMMUNICATIONS SUPERVISOR –  
INACTIVITY SENSE...

22 (Ring Indicate) of the RS232-C interface.

Once the remote caller hears the 'answer' carrier tone from the modem, they normally switch on their modem and start sending the 'originate' carrier. Once the modem has detected the originate carrier, it makes pin 8 (Carrier Detect) on the RS232-C interface active. An active state of CD will continually reset the BYE 25-second timeout loop, preventing DTR from ever going low.

If the carrier from the remote user is accidentally lost, the BYE timeout loop is no longer reset, and after 25 seconds of no carrier detection the DTR is forced to become inactive for a short time, thus 'hanging up' the phone and resetting for the next call.

If only life were that easy! Unfortunately, some Telecom exchanges generate signalling tones which are detected as carrier tones by V.21 modems. This 'open-line' tone will appear if the remote user hangs up before the RCPM does. The open-line beeps are detected as carrier signals and continually reset the timeout loop, preventing BYE from 'hanging up' the phone from the RCPM end.

To overcome this problem there is a carrier detect loss counter in the BYE timeout loop. If a fairly large number of carrier losses are detected (greater than 25), the timeout loop forces a DTR low immediately, on the assumption that it is either looking at 'open-line' beeps rather than real carrier signals or (if it is indeed looking at real carrier) the line is so unreliable as to make continuation of the data transaction pointless.

### Communications Supervisor – Inactivity Sense

There is another timeout loop which runs in BYE. This is an inactivity timeout which is usually set for five minutes. If nothing has been typed by the remote user for five minutes, BYE will initiate a disconnect sequence for the caller. An optional warning ▶

# MICRO-EDUCATIONAL

AUSTRALIA'S LARGEST DIRECT-MARKETING COMPUTER SUPPLIER

## Price Isn't Everything

WINTER CATALOG OUT NOW Order your copy by phone NOW

Yes, it's true we have the LOWEST PRICES in Australia on QUALITY computer peripherals. It's also true that we have OVERNIGHT DELIVERY anywhere in Australia and offer 10 DAY MONEY-BACK and 6 MONTH FULL SERVICE GUARANTEES.

But did you also know that:

- ★ We are the largest direct-marketing computer supplier in Australia. Scouts honour.
- ★ We have excellent hardware servicing facilities.
- ★ We only sell TOP-QUALITY products.
- ★ You can order by PHONE using BANKCARD with complete security. Guaranteed.
- ★ You get to speak to people who KNOW about COMPUTERS. (George or Bernard).
- ★ We treat you like a FRIEND-OF-THE-FAMILY.

So next time you can't find a parking spot or the computer store salesman doesn't know what you're talking about (much less what he's talking about) give me a call. You'll find that low prices are only part of the service.

*Hello again,  
As usual we're bursting at the seams with new stock.  
PRINTERS. Looking for the best price on Australia's top selling printer? We have a warehouse full of DT 80 Printers priced at \$275 on / \$339 inc. Going fast!  
DX-85 LOCKABLE DISK BOXES have just landed at \$35.  
Our last shipment lasted 2 hours. This time we're bringing a sea-container load! DISKS DISKS DISKS. Sold by the truck load. Priced like they fell off the back! If you buy disks elsewhere you are definitely deluged! 160 wordprocessing? The garage is full of top quality British-made Dataliver 300 electric copy holders. A4 size \$99, A3 \$129. If you buy one of these footswitch-controlled copiers (Normal Remo 299!) you'll be helping give the Mercedes its home but for winter so open your hearts all you diehard autophiles. Looking for drives? We have top quality Japanese SIMULAS for Apple II and compatibles. ATLAS 8 and SUPER 5 priced so low maybe I should tell you the price. Boss-1 keyboards, BMC green screens, VISION-80 cards. You name it. We've got it.*

**10 Day Money Back Guarantee.**

*P.S. If you're buying more than one of anything try twisting my arm on price. WE LOVE Bulk orders!*  
George -

### GUARANTEE

- 1 WE SERVICE WHAT WE SELL. WE WILL ONLY SELL QUALITY PRODUCTS FOR WHICH WE HAVE SPARES & DIAGRAMS. WE WILL NOT SELL CHEAP RUBBISH.
- 2 ALL HARDWARE CARRIES A 6 MONTH FULL SERVICE WARRANTY
- 3 ALL HARDWARE CARRIES A 10-DAY MONEY-BACK GUARANTEE IF GOODS ARE UNSATISFACTORY

### PRICE LISTS

GOODS IN STOCK  
APRIL 1984

(RING FOR BULK ORDER DISCOUNTS)

#### PRODUCT

##### DISKETTES

Diskettes, Micro-Educational, SS, DD.  
Reinforced hub, plastic library box  
100-499 \$3.20 \$2.80  
500+ \$2.90 \$2.49

##### BULK DISKS (No Boxes)

100-499 \$3.00 \$2.60  
500+ \$2.70 \$2.29  
Disk boxes, Lockable, hold 100 \$35 \$35

##### PRINTERS

Dot-Matrix printer, Micro-Educational \$325 \$275  
DT80  
Serial option for DT80 \$95 \$95  
DT80 printhead \$65 \$55  
DT80 ribbon \$12 \$10  
CITOH 1550 dot-matrix printer \$985 \$875  
CABLES: IBM, OSBORNE, TRS80, TI 99, BBC, etc \$35 \$35  
MicroBee cable \$50 \$45

##### DRIVES (Apple compatible)

TEAC Slimline drive \$339 \$299  
Atlas Slimline Drive \$339 \$299  
Chiron Slimline \$315 \$275  
ADMATE squareline drive \$339 \$299

##### MONITORS

BMC Green Screen (Japanese) \$195 \$170  
Yang Jen 12" monitor, amber, 18MHz \$195 \$170  
Yang Jen Colour Monitor, Composite, PAL, RGB, NTSC \$495 \$445  
Kaga Denshi Vision III RGB col mon \$725 \$625  
Kaga Denshi RGB cards for Apple \$110 \$99

#### PRODUCT

##### APPLE PERIPHERALS

Disk drive controller card \$90 \$80  
RS 232 Serial Interface \$95 \$90  
Automatic Ice parallel I/F and cable \$110 \$99  
Automatic Ice Direct Connect Apple \$369 \$319  
Modem  
Automatic Ice RS 232 Direct Connect Modem \$345 \$299  
Z80 card \$90 \$80  
IEEE-488 Card + cable \$295 \$265  
Epromwriter & Manual \$110 \$99  
Vision-80 80 col card for Apple II or \$179 \$179  
Ile (spec)  
Vision-80 128K Ramcard \$395 \$345  
16K ramcard \$90 \$80  
Music Machine includes speakers \$145 \$120  
S.A.M. Speech Synthesiser \$65 \$65  
Wildcard, Snapshot or Replay, ea. \$90 \$80  
Clockcard \$125 \$110  
SMC high-resolution Lightpen \$245 \$200  
Power Supply (7A) \$110 \$99  
Dataliner 300 electric copypolder \$99 \$99  
Clip-on fan, includes surge suppression \$65 \$55  
Joystick \$45 \$45  
Koala Pad graphics entry tablet inc software \$180 \$160  
Game Port Extender (2 socket) \$36 \$35  
Game Port Extender (2 socket + Vision80/Zardax mod) \$50 \$50  
RF Modulator \$40 \$34  
Apple Mouse Keyboard function extender for II+ \$79 \$79  
DT 80 Ribbons \$12 \$10  
Monitor stands, swivel & tilt \$25 \$20

*"These are days I'd give my right hand to be ambidextrous!"*



17 PARK ROAD GARDEN SUBURB NSW 2288.

(049) 436805

(049) 430624

SEND FOR FREE CATALOG



# MICRO-EDUCATIONAL PTY LTD

AUSTRALIA'S LARGEST DIRECT-MARKETING COMPUTER SUPPLIER

## DISKS



**\$29**

(EX TAX)

**\$32**

(INC TAX)

Delivery  
1 Box \$2  
More than 1 Box \$5  
(Courier Del.)

## LOCKABLE DISK BOX

**\$35**

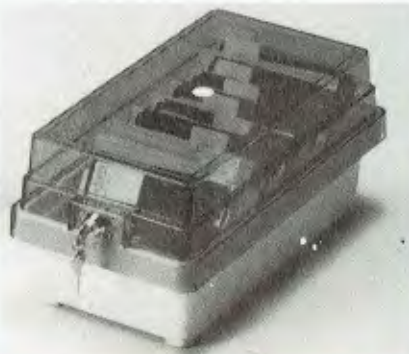

\$2 post

**TOP QUALITY**

## BMC 18 MHZ MONITOR



GREEN  
SCREEN  
MONITOR

**\$195** inc tax **\$170** ex tax

## MICRO-EDUCATIONAL DT80 PRINTER

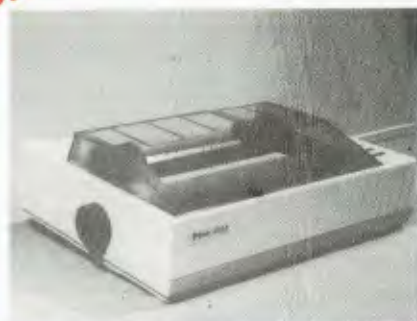

**\$275** ex  
**\$325** inc

*Reduced AGAIN!!*

+ \$8 courier delivery

- ★ Australia's Top-selling Printer
  - ★ Epson MX80 Compatible
- GRAB ONE NOW!**

- ★ Friction/Tractor
- ★ 80 c.p.s.
- ★ 6 Months Full Warranty

*6 Month Hardware Warranty*



**\$275** ex  
**\$315** inc

## SUPER 5 DRIVE APPLE-COMPATIBLE SLIMLINE

## \$45 APPLE II/IIe JOYSTICK



## EA AMBER MONITOR



High Resolution  
(80 x 24)  
To suit all  
microcomputers

**\$170** ex  
**\$195** inc  
+ \$8 Courier

### HOW TO ORDER

- 1 PICK UP THE PHONE
- 2 DIAL ONE OF OUR NUMBERS
- 3 TELL ME WHAT YOU WANT TO BUY  
(YES, I'LL TALK TO YOU ABOUT IT)
- 4 TELL ME YOUR BANKCARD NUMBER
- 5 IT WILL BE DELIVERED TOMORROW MORNING BY  
WARDS EXPRESS AIR COURIER (\$5 or \$8 for printers)

It really is that easy. And it's guaranteed by Australia's largest direct-marketing computer supplier. Us. If you prefer, you can send your order by mail or drop in (phone first) to buy direct. Easy.

OFFICE HOURS: 9—8 weekdays/9—2 Saturday



# VIDEO MONITORS

**Get a clear honest image!**

Computer data and graphic displays never looked better, brighter, sharper

## High Resolution

● Recommended Display Characters: 1920 (80x24).

- High quality, non-glare CRT.
- Compact and Lightweight with all Controls Inside Front Panel.
- All units 100% Factory Burned-In.
- 800 lines centre resolution.
- Suitable for Apple®—and other computers. (Apple is a registered trademark of Apple Computer, Inc.)
- Green or Orange Phosphor available.
- 18 MHZ.
- Direct Import Price.



SCHOOL AND CLUB BULK BUYS—  
Please ring for pricing

Ritron 11 Monitors are now available to increase our range of Data Displays. They feature a unique adjustable swivel base that tilts forward or back 30 degrees and swivels right to left 60 degrees. Technical specifications are listed below:

### SPECIFICATIONS

CRT SIZE  
12 inches non-glare 90 degree deflection  
INPUT SIGNAL  
1.0-2.5V p-p composite video signal  
INPUT IMPEDANCE  
Normal 75 ohm, high approx. 50K ohm  
INPUT TERMINALS  
RCA phone jack  
RISE TIME AND FALL TIME  
Less than 25 us  
VIDEO BANDWIDTH  
20 MHz + -3dB  
SCANNING FREQUENCY

Horizontal: 15.75 KHz + -0.5 KHz  
Vertical: 50 Hz/60 Hz  
Horizontal Retrace Time: Approx 8.5 us  
Vertical Retrace Time: Approx 800 us  
PHOSPHORS AVAILABLE  
Amber, Green  
RESOLUTION  
Centre: 1000 Lines  
Corner: 800 Lines  
Geometric distortion: 2% or less  
Linearity: less than 2%  
CONTROLS  
Front: POWER ON/OFF, brightness  
contrast  
Rear: V-Hold H-Hold V-Line V-Size



Green \$179.00  
Amber \$199.00

School and Dealer Enquiries Welcome

## JUKI PRINTER WITH 8K BUFFER Daisy Wheel 18cps \$1045



**Save 5 minutes each print run.**  
A high quality daisy wheel printer with a large buffer so it won't tie up your computer. The JUKI uses the wide range of Adler wheels and readily available IBM selectric ribbons. (Selectric is a Registered trade mark of IBM).

Errors & omissions excepted.

## 2.4 Mbyte CP/M system for \$2700



Yes that's right 2.4 Mbyte and the Ferguson Bigboard II you get a 4MHz Z80 system with two RS232 ports plus a centronics and STD bus expansion. If you want we can add Eprom programming facilities. Comes complete with CP/M80. Check it out at our computer division C-Tech in A'Beckett St.

## ROD IRVING ELECTRONICS

425 High St., Northcote, Vic. 48-50 A'Beckett St., Melb., Vic.  
Phone (03) 489 8866, (03) 489 8131, Mail Order Hotline (03) 481 1436  
Mail orders to P.O. Box 235 Northcote 3070 Vic. Minimum P & P \$3.00.

Please address tax exempt, school, wholesale, and dealer enquiries to: **RITRONICS WHOLESALE**  
1st floor 425 High St. Northcote 3070 (03) 489 7099  
(03) 481 1923 Telex AA 38897

message, usually accompanied by many ASCII BEL characters, may be issued 30 seconds before an inactivity timeout will occur.

The disconnect sequence may simply force DTR to become inactive, but usually it involves passing control to a logging program which will record details of the timeout for further administrative action by the SYSOP. In RCPM environments a program called Timeout is usually executed, which records an inactivity timeout against the caller's name in the system log file and logs the time of disconnection.

### **Communications Supervisor – Transaction Format**

When a caller first logs onto an RCPM system, the BYE program asks several questions related to transaction format. The first question relates to the number of ASCII NUL characters that will be inserted after each carriage return or line feed. This allows remote users with slow terminals (that is, hardcopy terminals and certain Apple 80-column cards) to avoid losing characters sent directly after a CR/LF, by specifying some number of NUL characters (which don't display) to be sent while their slow device is getting ready to display characters again. Most users with fast display devices will answer '0' to this question.

The second question relates to whether the remote user's terminal can display lower case ASCII characters. If the user answers 'N' to this question, BYE will fold all lower case characters to upper case before sending them to the remote user.

The third question is optional and, if used, asks the remote user if they want to change the modem mode at the RCPM end from answer to originate. This allows users who experience difficulty in maintaining contact while in ORIGINATE mode at their end to switch modes early in the data transaction.

### **Communications Supervisor – Program Load**

After connecting a caller BYE will display an ASCII text file, if required. This is usually a message announcing the name of the system and so on. BYE has the capability to preload a COM file and pass control to it once it has completed its part of the connect procedure. Having the file preloaded minimises delays for the remote user. For RCPM systems the file that is executed is normally ENTRBBS, which is a logging program written in compiled BASIC.

### **Communications Supervisor – Function Keys**

The BYE program has several preprogrammed functions that are activated by control keys on the local terminal.

A Control-Q on the local terminal gets BYE to issue a message to the remote user, saying 'System Down In Five Minutes', which is handy for encouraging users to get off the system when the SYSOP wants to use it.

A Control-O on the local terminal gets BYE to issue a message to the remote user, saying 'Message From Operator', which is handy for quickly getting the attention of a user who is having problems.

A Control-N on the local terminal gets BYE to immediately disconnect the current caller, which is extremely useful for getting rid of twits who are abusing the system.

### **Communications Supervisor – SYSOP Access**

While BYE is waiting for an incoming call, a control-C may be struck on the local terminal. When BYE completes the current 25-second timeout loop, it will go into a supervisor mode rather than start the next timeout loop. It reports the number of connect attempts, successful connects and inactivity timeouts. BYE then gives the SYSOP the option of re-entering BYE, for continued polling for remote access, or of terminating BYE and exiting straight into CP/M. This allows the SYSOP to regain control of the system for maintenance purposes, without having to reboot. The SYSOP would also switch the modem to 'busy' (off-line) mode while local maintenance was going on, so the phone appears busy to callers.

### **Communications Supervisor – Other Options**

The BYE program has a number of other options. Whether you use them or not will depend on your operational needs and hardware.

Optional motor control of disk drives is supported so your drives can be shut down between calls if your hardware is capable of it. An optional password question can be inserted to restrict access to the system. An optional hardcopy log of everything typed by the remote user (but not of anything sent from the RCPM system) can be kept if you have a reliable printer connected to the system. Optional sense switches can be used to control whether the local console function keys are active, whether the hardcopy log is active,

## **RCPM System**

whether a password is required and whether the remote user should be blacked out from local keyboard activity. An optional clock facility is available.

### **Communications Supervisor – Installation**

The current version of the fully tested and debugged BYE is executed outside the normal CP/M system image. This means you must construct a smaller than normal CP/M system with space 'above' CP/M in your system memory, to allow BYE to load and remain resident. Depending on which options you enable in BYE you can expect it to occupy between 2K and 4K of memory. Your CP/M system must be smaller than normal by this amount. For instance if you normally run a 64K CP/M 2.2 system and want to use a 4K version of BYE, you would need to construct a 60K CP/M system using MOVCPM and so on for RCPM use.

When BYE is assembled, it must know what its absolute load address is. This is set by an equate in the source code. The absolute load address must be above the end of the CP/M system image. When BYE is executed as a COM file, it relocates itself to the selected absolute load address as it passes control to that address.

BYE patches the CP/M BIOS jump table so the console and printer entries in the jump table point to BYE rather than to the BIOS console and printer routines. BYE controls redespawning of BIOS calls to those routines as necessary.

One characteristic of BYE you should be wary of is that it should not be initially loaded when the carrier detect from the modem interface is active. While this is an unlikely event in actual operation, if you are testing your BYE with the modem disconnected from the computer, your computer's RS232-C interface may make control lines active when they are open.

### **Communications Supervisor – Alternatives**

An updated BYEII program is now available from the US and is in use on a few systems here. It has not ▶

# RCPM System

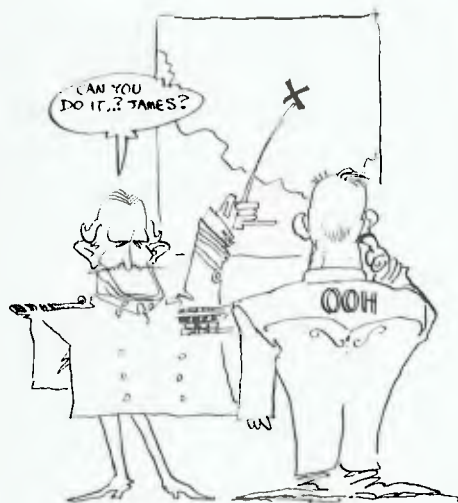

ALL INTRINSIC COMMANDS MUST BE REMOVED FROM THE CCP....

been fully tested and debugged for all options under Australian telecommunication conditions. BYEII is a much more modular program than the original BYE, is easier to maintain and has much to recommend it. I hope to have a fully tested BYEII before long.

BYEII has an optional load position below CP/M, which may be advantageous if you can easily construct a smaller than normal CP/M system; but reports from the US suggest that operation in the 'below CCP' mode are much less reliable than the 'above CP/M' position.

Not everyone uses BYE; some SYSOPs have written their own Comms Supervisors. CBBS-type systems have a BYE-type routine buried in their code somewhere.

## BASIC Programs – Introduction

The original RBBS programs in Microsoft BASIC were almost impossible to maintain. The first thing I did to them was restructure the code so there is only one program statement per line and the program structure is obvious. It took several weeks of very hard work to achieve this, but I have never regretted investing that time as it has made maintaining and enhancing the programs a chore rather than a nightmare. It also enabled me to quickly clear up a number of serious bugs which had previously been well

disguised in the original code.

The code shows the work of many different individuals over a long period of time. The programs probably deserve a massive rewrite by this time but are unlikely to receive it, at least from me. Where possible I have tried to retain the original line numbers, so any worthwhile enhancements developed in the US can easily be incorporated in the Australian versions and vice versa. The line numbering is crazy, but I suggest you resist the temptation to use RENUM on it.

The programs are meant to be compiled with the MBASIC Compiler version 5.3. Most features will also work under the MBASIC interpreter for easy debugging, but *some won't!*

## BASIC Programs – Entry Program

ENTRBBS is the RCPM entry program. This program is responsible for most of the system logging functions. It maintains a users' list and a callers' log.

When a caller logs into an RCPM system ENTRBBS will ask them for their name. This is checked against a list of known system users and unless an *exact* match is found the caller is also asked for a locality and is treated as a new user. New users are shown a text file which would normally contain help information of some sort and then asked to answer a user survey. Failing to answer more than one question on the survey gets the caller thrown off the system immediately. The user survey information is very useful to the SYSOP in determining what type of people are using the system.

After successfully completing the user survey the new caller rejoins the path that a regular user follows after his name has been found on the user list.

Each caller has his entry in the users' list updated with each call, to show the total number of log-ins and the date of the last log-in. A separate file records the caller's name, the time they logged in and their current user status.

A search is made of the message system to see if there are any messages waiting for the caller, and if so the message numbers are displayed.

A file with information on when the latest system update was made is displayed and the caller asked if they want to read the latest system information file. If they answer 'Y' the system bulletin file is displayed. This is a standard ASCII text file organised in whatever way the SYSOP wants.

The Software Tools RCPM bulletin file is arranged in reverse chronological order with the most recent system message first.

After the bulletins, the caller is either passed to CP/M, if their user status is 'new', or given a menu to select their next move, if they have higher user status.

User status is determined at the discretion of the SYSOP. All new users are automatically classed as new and will remain at that status unless the SYSOP takes explicit action to change their status. User status is recorded in the users' file. Users can also be given 'twit' status if they are considered undesirable by the SYSOP, and they will be denied system access by ENTRBBS.

The files which ENTRBBS creates for logging will be created with the appropriate system attribute bits set (to be discussed later), if they don't already exist. Any maintenance on these files is done with a normal ASCII text editor, such as ED, WM, WS or VEDIT.

Remote access to the system for the SYSOP for maintenance purposes is available through a special set of passwords. These passwords are not echoed, are not constant and have a component which varies regularly and automatically as an added security measure. Not all the characters in the passwords are meaningful and these redundant characters can be used as identifiers if you have several SYSOPs for one system. All SYSOP accesses are separately logged, with the redundant identifiers going into the log file.

## BASIC Programs – Message System

The message system is called MINIRBBS. It provides a structured way of leaving and receiving messages from other system users. On entry to the program the user is informed if there are any messages waiting for them.

Messages can only be left to known system users as checked against the user list. The message system is largely self-explanatory. A command connector feature is available which allows several commands to be concatenated. This is a surprisingly powerful feature once its significance is realised.

Messages may be made public (visible to anyone) or personal (only visible to the sender, receiver and SYSOP), and passwords may be used to control deletion of messages.

As well as the normal functions of MINIRBBS, it is also a very important ▶

# HI-TECH C

An Australian developed Z80 C Compiler  
that runs rings around the opposition.

## Features:

- Compiles Full V7 C — including enums and structure operations
- Produces fast, compact code — outperforms all competitors
- Complete I/O library
- Source for libraries included — no royalties
- Easy to use — one command compiles, assembles and links
- Powerful debugging tool included
- Command line I/O redirection
- FAST floating point
- Locally developed and supported
- Supports ROM-based software
- Includes MACRO assembler, linker and librarian

## System Requirements:

Z80 CPU  
56Kb RAM  
200Kb Disk space  
CP/M 2.2  
or any UNIX system

## Disk formats:

8" SSSD  
\* Kaypro  
\* Osborne  
DEC Rainbow  
Others: enquire  
(\* \$5 surcharge on these formats)

## Pricing: (all prices include tax)

Compiler — limited support	\$125
12 Months full support	125
Manual only (refundable)	25
P & P	7
Cross Compilers — enquire	

**Availability: NOW**  
(Watch for 8086 version soon)

**HI-TECH SOFTWARE**

P.O. Box 118, Eastwood 2122 Ph: (02) 85-4552



WRITER BOLTON CLEARING UP  
WELL DISGUISED, SERIOUS BUGS.....

tool for the SYSOP as it allows him to look at the various system log files, edit previously left messages and so on.

Any files which MINIRBBS creates will have the system attributes set on them.

MINIRBBS is now a very large program. It will not execute under the MBASIC interpreter for debugging unless you have a very large TPA. Similarly, it cannot be linked with L80 in its compiled form unless you have a very large TPA. A 62K TPA is adequate to satisfy both requirements, but if you have less TPA you will need to have a disk to disk linker, like PLINK or LYNX, and forgo debugging under the interpreter. In any case, the message editor in MINIRBBS only works in the compiled form.

The name of the current caller is passed around between the various BASIC programs by a letterbox file, so that a user only has to enter his name in the system once. If you have a clock in your system date information can be read from the clock, otherwise you will have to get users to enter the date manually.

### BASIC Programs – Message Utility

The UTIL program is available only to the SYSOP and is used for maintaining the message system. It will purge the MINIRBBS message files and create archive files for back-up purposes. It is fairly slow in operation (go and make a cup of coffee while it grinds away), but should only need to be used every two or three weeks. UTIL also has several other useful functions for the SYSOP, including being able to erase any file, TYPE any file and get a full directory of all the files on a disk. A new message summary file can also be built from the main message file.

The only trap to watch out for

when using UTIL is to make sure you have enough space on the disk for the various back-up files that UTIL creates during the course of a message purge. If you don't have enough space ... don't say I didn't warn you!

If you leave UTIL out on the system as an 'invisible' file, you obviously shouldn't call it UTIL. In any case, there are a number of traps built into UTIL to log any attempts by non-SYSOPs to access the program.

### BASIC Programs – System Exit

The EXITRBBS program provides an orderly exit from the system. It allows the user to leave a comment which is only viewable by the SYSOP and records the time of leaving the system in the callers' log file. On most systems EXITRBBS is actually called BYE and the real BYE program is called something else. EXITRBBS passes control to the real BYE program when it has finished its logging.

A closely related program called Timeout is used by the Comms Supervisor for logging forced disconnects due to inactivity timeouts.

There are several identical routines between the various BASIC programs on the system, for ease of maintenance. The clock access routines are a good example of this.

### System Utilities – File System

Several of the system utilities described below make use of some special features of the RCPM file system. The basic problem is that there are numerous files which are required to run the system but which the remote user should not be aware of for a variety of reasons. CP/M provides us with the SYS attribute which will make a file invisible as far as directory listings go. This is a good start, but SYS files can still be freely accessed by any program. What is needed is an additional attribute which says this is an RCPM system file, and which is totally invisible unless you already know its name.

This extra attribute bit is on the second character of the file name in the directory, and is called the 'f2' attribute. When f2 is set on any file it does become invisible to the other RCPM utilities. Files with f2 set cannot be TYPED, transferred with XYAM or whatever. Usually, both f2 and SYS attributes are set simultaneously, but occasionally only the f2 attribute will be set. For instance, I set f2 only on some of my system help files which I want to make sure get read fully at least once. The

remote users can see these help files in the directory, but cannot download them with XYAM. The only way they can look at them is with the 'help' utility, which means the files must get read at least once.

At this stage I might explain a basic dictum of security on RCPM systems. If you don't want remote users to use it, don't have it on the system. Of course the SYSOP must have some maintenance programs on the system but these must be carefully and fully protected with passwords and so on, and they must be kept to an absolute minimum. Several local SYSOPs have learnt this lesson the hard way.

### System Utilities – Tag

Tag is a utility for simultaneously setting or resetting multiple attribute bits on files. Conditional assembly will yield four different versions of TAG which will set/reset different combinations of attributes. You should end up with:

TAG2 which sets R/O and SYS  
TAG3 which sets R/O, SYS and f2  
TAGFR which sets R/O and f2  
TAGFS which sets SYS and f2.

R/O and SYS can be set individually with the CP/M STAT utility.

Tag will accept wildcards in its file names to match. TAG is not a utility you need to keep on-line, it is for maintenance only.

### System Utilities – Synonym

Synonym will construct a loader COM file which does nothing but load and execute another COM file. The real benefit of using Synonym is its ability to pass out fixed command lines to the program you really want to execute. For instance, the Dirall program on the Software Tools RCPM is simply a loader program for DIR, which passes out the fixed command line '\$A' – which causes DIR to look at all the disks on-line. It was simpler for users to be told to use Dirall to see what was on all the drives than to explain to them that they needed to type 'DIR \$A'.

Synonym has adequate documentation on its use at the start of its source file. Synonym is not a utility you need to have on-line, it is for maintenance only. Synonym is written in 8080 assembler.

### System Utilities – DIR

DIR.COM replaces the intrinsic DIR command in the CCP. DIR.COM sorts the directory in alphabetical order and can expand the internal directories of LBR files. DIR.COM is a program

# Starting an RCPM System Part 1

called SD-77 with all the dangerous equates turned off. A companion program called DIR64 displays the sorted directory in three columns instead of four, for use on 64-column screens. Normally, the DIR utility is supplied as a file called DIRW.ASM. It needs to be assembled twice with appropriate equate sets: once to get DIR.COM and once to get DIR64.COM. It is, obviously, written in 8080 assembler.

## System Utilities – Chat

Chat is a remote conversation utility. It allows a civilized keyboard conversation between the SYSOP and a remote user. The program will ring the bell on the local terminal for 30 seconds to summon the SYSOP. If the SYSOP doesn't respond in that time the user is returned to CP/M. Chat does automatic new lines when in the conversation mode. Chat is written in C and has its own help display for command line errors.

## System Utility – Flip

Flip allows changing the modem mode as discussed previously. It is only useful if your modem supports mode switching via pin 11 (STF) on the RS232-C interface. The code is highly dependent on your USART, and is currently set up for a 2651 USART. Flip is written in 8080 assembler.

## System Utility – Find

Find is an ASCII string match utility. It is used for searching on-line catalogues for programs of specific interest. The catalogue files have the f2 attribute set, so they cannot be accessed by XYAM, TYPE and so on. The catalogues have the file type of .ALL, so Find is set up to recognise files of type .ALL and search them even though they have f2 attribute set.

The version of Find for RCPM use is now quite old, but don't be tempted to replace it on your RCPM with any of the later versions from the user groups, as they are lacking in some vital security features and offer no increase in functionality for remote use. Find is written in 8080 assembler and has its own help display for command line errors.

## System Utility – Type

Type is an ASCII file display utility. It will accept wild card file names and display matched files sequentially. It will automatically uncompact 'squeezed' files and will optionally display only the first 80 lines of a squeezed file. It can be set up to ignore specific file types as well as ignoring files with

the f2 or SYS attributes set. TYPE is written in C and has its own help display for command line errors.

## System Utility – LType

LType is a utility for typing text files contained with LBR type libraries. It will automatically uncompact squeezed files in libraries. It will optionally display only the first 80 lines of an LBR text file. LType is written in C and has its own help display for command line errors.

## SYSTEM Utilities – Help

Help is a utility for displaying system help files in a structured manner. You should get the original set of Help files from the SIG/M collection for information on how Help files are structured. If the user just types 'help' with no command line argument, the Help utility looks for a file called QUICK.HLP which should be a one page summary of system commands. If QUICK.HLP cannot be located it displays an internal help message.

There are many versions of Help around. Version 1.5 is the correct one to be using for RCPMs at the moment. Earlier versions and later versions have a fatal flaw in that remote users can crash the system, so don't use them. Help is written in 8080 assembler.

## System Utility – Password

If you absolutely must have dangerous files out on your system for the SYSOP to use, you should run them through Password. This utility will place a password on any CP/M .COM file, which must be correctly matched before the file will execute. Don't ever do this to your only copy of a program as you can't change or remove the password easily. You can run a program through Password several times to put multiple passwords on a program. Password is written in 8080 assembler.

## System Utility – User

User replaces the CCP intrinsic command. It allows you to set up access to user areas with passwords, with different passwords having access to different groups of user areas. The set-up of the password file is fully described in the 8080 assembler source code file.

## System Utility – Whatsnew

Whatsnew is a program for rapidly showing what files have been added or deleted on a disk. It is useful to both the SYSOP and user in seeing if any files have been uploaded to the system by users. Whatsnew's operation is automatic; as soon as a file has been added to a disk, Whatsnew will report it as new. Every so often the SYSOP will need to run the update mode of Whatsnew to bring its internal directories up to date, so the Whatsnew display doesn't get too cluttered.

Whatsnew's features and operation are described at the start of the 8080 assembler source file.

## System Utility – XYAM

XYAM is the remote communications program for RCPM use. It is constructed from the normal YAM program with XYAM and 'restricted' defines enabled. It is fully described in the YAM documentation. XYAM is written in C.

## General Utilities

As well as the specific utilities for use on or in supporting an RCPM system, you should have the following CP/M system utilities from the user group collections:

- Squeeze/Unsqueeze – for file compacting
- LU – for library building/maintenance
- Scrub/Unscrub – for massaging WS text files.

These utilities are fully described in the relevant UG volumes.

## Other Tools

To adequately support an RCPM system from the standard set of distribution files, you will need the following commercial programs:

- MBASIC-80 interpreter
- BASCOM-80 compiler and utilities
- BDS C Compiler
- MAC or RMAC assembler
- SID-80 debugger
- WordStar.

And you'll need a good screen editor, like WordMaster or VEDIT – not WS in non-document mode.

Please don't rip these off. They are all generally useful software tools that someone seriously interested in program development would expect to have anyway. □

## Business is making money work

- \* Excalibur 64 is the low cost business computer
- \* Up to 2000 Kilobytes of stored information using space saving low cost diskette storage
- \* CPM 2.2 Disk software for all business applications
- \* Professional presentation colour and graphics
- \* Word processing in 80 x 24 format
- \* Direct output to typewriter quality printers
- \* Professional typist keyboard
- \* Designed for the Australian businessman

# a day in the life of the

*'I chose value, quality and flexibility in a computer for my business. The Australian designed and manufactured Excalibur 64 at under \$1000 fulfills my business needs.'*



## Computers: indispensable to education

- \* 64 K RAM on board
- \* Low cost cassette interface for educational programs
- \* Forth, Pascal, Fortran available in ROM and tape
- \* Essay writer: tape and ROM word processor
- \* Fast 4.0 MHZ action
- \* R.G.B., video and R.F. standard monitor and TV connection
- \* Standard RS232 and centronics parallel interface
- \* Z 80 A CPU
- \* Advanced on board colour basic
- \* Designed for the Australian student

*'I didn't like to study before I had a computer. My Excalibur 64 has made study easier and fun.'*

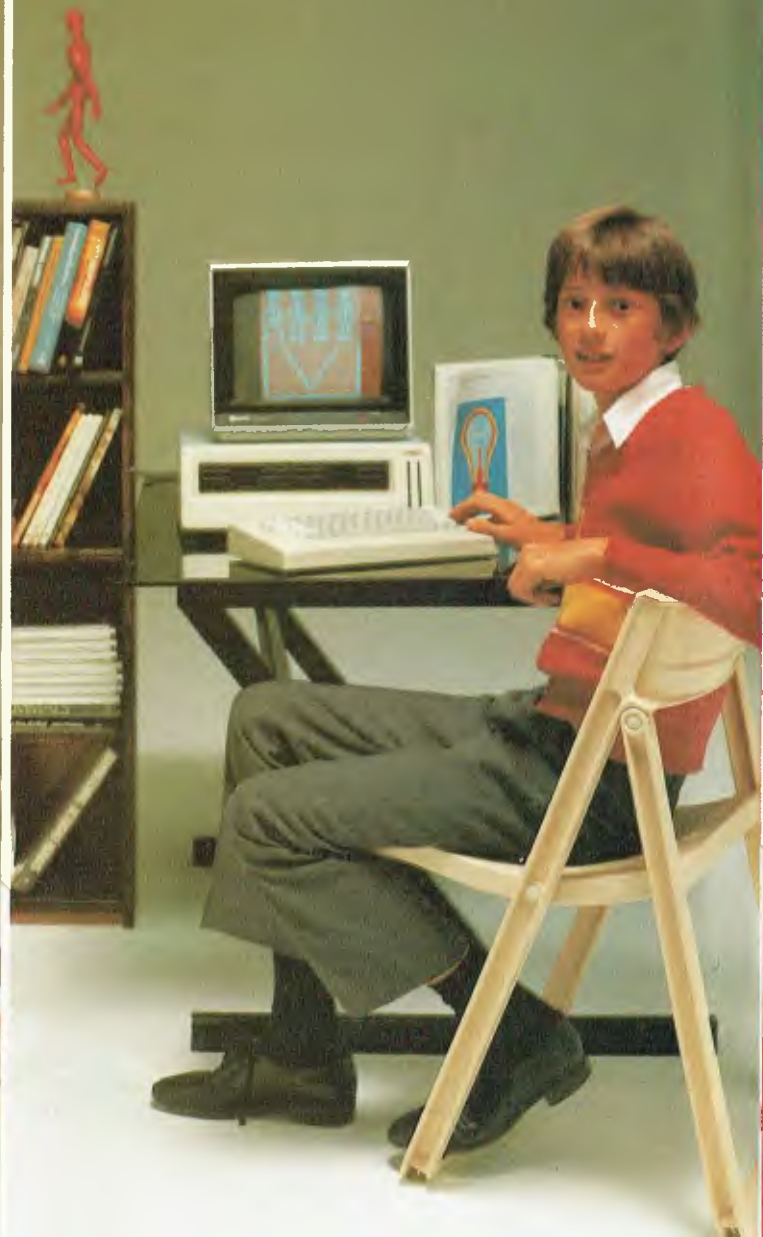

Everyone gets tired of work and wants to play

- \* Games
- \* Graphics (126 programmable graphics and 126 preprogrammed)
- \* 26 colours
- \* High speed
- \* Low priced entertainment programs
- \* 640 x 288 High Resolution
- \* 320 x 288 Low Resolution
- \* Joy stick controller available for all games
- \* 4 channel sound - music synthesiser
- \* Real time clock
- \* Voice synthesiser
- \* Designed for the Australian home

# Excalibur 64

*'Until our Excalibur 64 came home, I was afraid of computers. I'm not now. I can watch my family growing into the future.'*



Ask your local computer retailer for the Excalibur 64

He can demonstrate any:

- Business
- Educational
- Games Package Programs

Let your sense of value make the decision for you and your family. The Excalibur 64 is designed, developed and manufactured by Australians.

Something this good has to be Australian.

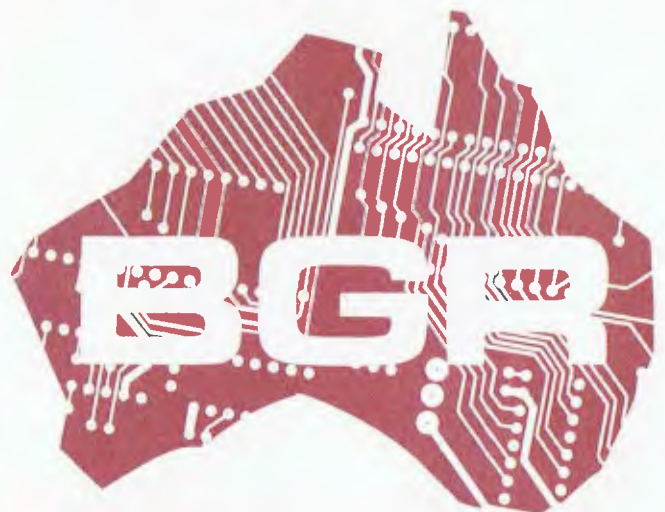

Dealer enquiries:  
BGR Computers PTY LTD  
GPO Box 5302 BB  
Melbourne 3001  
(03) 383 4200



Factory: 10 Breese Street, Brunswick,  
Melbourne.

# If a picture's worth a thousand words...

SPECTRAVIDEO 328

COMMODORE SX64

COMMODORE 64

STAR GEMINI 10X  
C/64 Compat. with VICS Print 64

THE LARGEST  
RANGE OF  
64 SOFTWARE  
IN AUSTRALIA

KOALAPAD  
TOUCH TABLET

SPECTRAVIDEO 318  
FULL RANGE OF SOFTWARE  
AVAILABLE.

You can't say we didn't tell you that the Spot has the largest range of C64 software, plus a wide selection of hardware from the leading manufacturers - at the most competitive prices.

With expert advice and reliable service.

Thinking personal computing? Then there's only one Spot... sorry two!

*the*  
**Computer Spot**

MLC Centre, Martin Place  
Sydney. Phone: 235 2971.  
Eastgate Centre, Bondi Junction  
Phone: 358 5208.

By Andrew Farrell



LET'S START this month by clearing up a few nasty rumours which are circulating at the moment. First, Commodore is *not* going broke; and perhaps I should point out that even if they were, the chances are support for their machines would not cease overnight. The Texas Instruments TI-99 is a classic example of what does happen after a micro is withdrawn from production: third party software houses are falling over each other in a desperate bid to meet the huge demand for software which now exists. Second, production for the Australian version of the Vic 20 is still in full swing, though the American version has been discontinued from the assembly line.

### New Commodores

Lastly, a big yes to the questions regarding the new 264 and 364. They do exist and we can expect to see them available in Australia early next year. Initial supplies will be quickly gobbled up by the massive American market, especially since the retail price of the 264 is under \$500. Calm down, your new C64 has not been replaced by a bigger and

better Commodore. The 264 and 364 are more business oriented, hence the nickname they have earned as 'The Productivity Machines'. The new series will be compatible with existing peripherals, such as the 1541 disk drive and MPS-801 printer. Perhaps that isn't such a great thing, though it does mean if you want to upgrade there's no need to trade in parts you've already got.

### Improvements

One look at the features and you'll notice many improvements over the 64 which will impress in business and educational areas. A superior BASIC with additional commands to support graphics and other features was the first obvious enhancement. Of course there's the usual full 64K of memory, with 60K available to BASIC programs. There are also windowing capabilities, for split-screen effects, and a massive 128 colours (16 primary colours with eight levels of intensity). The machines also have the same high-res graphics as the 64; however there are no sprites from hardware. And, at last, they have a built-in machine code monitor. Typists will like the new keyboard, and beginners will love the help button. The cursor keys are now located on separate buttons, which I'm still not sure is an improvement. Most noticeable of all, the 264 and 364 are very attractively housed in a new dark-grey housing. (Yes, it does matter.)

### Business

Now for the real meat in the pie. The new machines have built-in software, including a word processor, spreadsheet and file manager. Using the window capability, it is possible to run these packages simultaneously. When the system is turned on, several options appear. Pressing the appropriate function key will select any of the built in software, or enter BASIC. What a brilliant system! No more waiting for programs to LOAD or remembering tricky commands.

### Education

This unit is a big step toward Commodore cleaning up the educational market. Many variations of the machine will

## 4TH WONDER OF THE WORLD

ETI Magazine's Circuit Techniques Volume No 4. The how, what, which, where, why and how much anthology of electronic components, circuits and techniques.

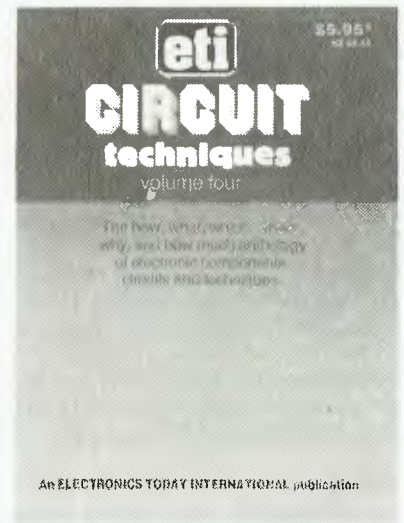

Now available on newsstands everywhere, this book is packed with articles on Analogue Delay Lines, Gain Control, CMOS circuits and how to make them work plus much, much more.



### CIRCUIT TECHNIQUES VOLUME 4

Available at your newsagent or from ETI Booksales, 140 Joynton Avenue, Waterloo, NSW 2017. Please add \$1.75 post and packing when ordering.

be produced with the ability to exchange any of the built-in software and include programs such as LOGO instead. The improved BASIC and HELP key will also be popular with students; as will the existing range of educational software for the 64, which will be upgraded to run on the new Commodore.

## Speech and a Fast Drive!

At last: a talking computer which really can talk, not just croak. The 264 and 364 will have on-board speech capabilities with a vocabulary of over 250 words. The synthesiser will probably be similar to the newly released Magic Voice which is a very understandable unit. Additional vocabulary will be available on disk or cartridge, with variations in inflection and species (male or female, and hopefully *not* all American). Commodore has also promised a fast disk drive and cassette unit. If and when they arrive, the drive will probably not be compatible with the 64. It's a pity.

## Overall

Very impressive stuff. Keep in mind though that there will be several variations of the 264 and 364, each containing different combinations of software and memory. In some areas I wonder how 'The Productivity Machines' can do anything less than replace the 64. However, I think the 64 is here to stay as the most popular home computer around.

## Vicsprinting

Any attempt by Commodore to build a real printer would be greatly appreciated by the large proportion of business users still struggling with interfaces. I did mention some time ago the availability of the Vicsprint Centronics interface. Well, bad news. Availability is almost zero at the moment, with a worldwide

shortage of the chip used on the interface. Worst of all is the increasing number of reports from serious users that the interface is causing software to fall over or crash. This problem usually occurs during disk access or when printing is done while a channel to the disk drive is open. As yet, there are no quick solutions to the problem. For those of you looking to use one with EasyScript, or just for program listings, there are no problems. When they do become available again, the version distributed by OziSoft will connect to the cassette port or user port for power, instead of the expansion port. This will solve any hassles with cartridges conflicting with the unit. Computer Technics will also be selling a version built into the Gemini Printer. There has been great demand for this product recently, which says something about the types of printers people are buying. There is an alternative I'm looking into at the moment, which I may have some more news on shortly. The user port at the back of the Commodore 64 is virtually a Centronics port. All it requires is a driver program, such as the one built into EasyScript, to get things moving.

## Sydcorn 64

The Sydney Commodore 64 User Group is now on the road after a few problems in getting the cogs turning earlier on. It now produces a very nice newsletter called 'Peripheral', and has a large collection of public domain software. The monthly meetings are held at 6.30 pm on the second Tuesday of each month, on the fourth floor of the YWCA. I should mention at this stage that I recently stepped down from the job as president, in order to pursue other areas of interest. Any enquiries should now be directed to the Secretary, Michael Stead, on (02) 99 3370.

## MailBox

George Begetis of Burwood has written asking for information about the Audio/Video port on the Vic 20. Specifically, which coloured wires go to which pins? There are several different versions of the Vic-20 RF modulator around, so I'll have to leave that end of the cable alone. At the computer end we have five pins which are numbered 3, 5, 2, 4, 1 - from left to right. A full diagram appears in the user manual under Appendix L and in the reference guide under Appendix J. Now the colours: 3 is yellow; 5 is white or black; 2, the earth pin, is usually a bare wire or covered in a thin clear plastic; 4 has no connection; and 5 is red.

## Beginners

George also asked a good question regarding the notation often used in program listings which looks something like this; 10 PRINT "{ HOM }{22 CD}{REV}{17 SPC ... and so on" You may have seen something similar in various other publications. This is in fact a simple way of condensing long program lines which contain cursor controls. We can place the controls within print statements, to move the cursor around the screen from within our programs. All the editing keys, plus a few others, appear as reverse symbols when entered between quotes. To a great extent these are virtually illegible when listed on a Commodore printer. By using a special program we can make the printer change these codes into an abbreviated form. The above line may be entered by typing 10 PRINT" and the HOM key, 22 cursor downs, the reverse key followed by 17 spaces. Got the idea? The abbreviations used are very close to those appearing on the editing keys and in the ASCII and CHR\$ codes listed in Appendix J of the user manual.

★ Big River Promotions present ...

★ THE NORTH COAST  
★ **Computer**  
★ & ELECTRONICS  
★ Personal computers  
★ Fair Small business systems  
★ Video & Sound systems

★ JUNE 22-24  
★ ROLLER WORLD COMPLEX,  
★ GRAFTON, N.S.W.

★ OVER 60 EXHIBITORS BRINGING YOU A COMPLETE  
★ RANGE OF HARDWARE & SOFTWARE, ALSO THE  
★ LATEST IN ELECTRONIC TECHNOLOGY  
★

# YES YOU CAN PHONE THE VIC CENTRE MAIL ORDER DEPARTMENT STD FREE FROM ANYWHERE IN AUSTRALIA!

The **VIC CENTRE** mail order department is open now 24 hours a day 365 days a year, here you can phone **FREE** on **(008) 777 130** at any time whatsoever from any where in Australia.

## **YOUR PHONE CALL REFUNDED**

Try it **NOW**. Phone **(008) 777 130** to put your name on the mailing list and you will be credited your 20¢ for the local call charge against any future order that you place.

## **YOUR FREE "MENU"**

You will also receive **FREE**, if you have not already done so, a copy of the **VIC CENTRE "MENU"** (cost \$3.50). This is a 152 page book cataloging the majority of C64 and VIC-20 hardware, software and publications available in Australia to-day together with pages of hints and tips on the C64 and VIC. There is even an amateur radio section.

## **FREE USER NEWSLETTER**

Also once on the mailing list you will receive your regular **FREE** user newsletter which will hold technical tips, useful hint, specials and other benefits.

## **FREE STD PHONE CALL**

We have now installed for you the latest Telecom (008) phone service on which you can phone the **VIC CENTRE** order department from anywhere in Australia for the price of a local call. We will deduct from your order the 20¢ local call charge, making your call to us truly **FREE**.

## **FREE 24 HOUR SERVICE**

As well as the **(008) 777 130** number we have installed for you the very latest computerised telephone answering and ordering machine available from U.S.A. This will allow you to order 24 hours a day 365 days a year. During business hours we talk to you personally.

## **YOU CAN SAVE**

You can now save money: save time with the convenience and pleasure of shopping from your home, you can choose at your leisure the items that you would like delivered to your door. We have available for you almost any item of software or hardware available for Commodore in Australia to-day and if not in stock we will advise you, by phone or post, when it is expected in or suggest an alternative.



## **SPECIALS**

We will have specials from time to time for you that will be announced in your **FREE** users newsletter or you can phone our enquiry number (07) 397 0888 for further details.

## **STOCK**

You will find that we endeavour to keep in stock most items from Australia's and the world's most reputable companies including those listed below.

## **LARGE RANGE**

Our ever increasing range includes both software and hardware from:

*Commodore, Imaginering, Ozi soft, Kiwisoft, Progressive Software Company, Abacus, Romik, Fot, South Pacific Software, Quicksilver, Micro Applications, High Technology, Ashton Scholastics, ANZ Book Co., Computer Classics, Computer Market, Dataform, Kim Books, Pittwater Computers, Melbourne House, Lamasoft, Uni, Hcs, Creative, Auto Simulations, Pixel, Photatronics, Wizware, Microgenis, Currah, The Vic Centre, Computer Craft, Contronics, Vic Education and others.*

We also stock a large range of amateur radio equipment including *ICOM, YAESU, DLAWA and ATN* etc.

## **OUR GUARANTEE TO YOU**

Beside the manufacturers warranty you will have our personal guarantee to replace or repair any faulty item (in original condition and packaging) returned to us within 90 days of the date of your **VIC CENTRE** invoice date.

## **CREDIT CARDS**

We accept your Bankcard, Master card, Visa card and American Express for all phone and mail orders.

**SAVE** money, **SAVE** time and phone **FREE** right **NOW** from the comfort of your home.

What could be easier for you than placing an order with the **VIC CENTRE**. Phone the order department now on **(008) 777 130**.

For enquiries and local Brisbane orders phone (07) 397 0888 for prompt service.

Mail orders are also welcome at the **VIC CENTRE**. Write to:

**THE VIC CENTRE**  
**416 LOGAN ROAD,**  
**STONES CORNER,**  
**QLD. 4120**  
**TELEX. 40811**

**STD** orders only **(008) 777 130**.

**Local and enquiries (07) 397 0888.**

## **DISTRIBUTORS, SOFTWARE HOUSES, BOOK PUBLISHERS & MANUFACTURERS.**

If you wish your products to sell whether they be Commodore, IBM, APPLE etc. Contact Brian Beamish of the **VIC CENTRE** as we are looking to increase our range extensively.

THOUGH I've always freely revealed my background and interests to those who ask, some recent events highlighted the fact that I'd not done so to the readers of this column. So, here goes.

I've been employed as a member of the information systems department for BHP in Melbourne for over seven years. I started out cutting code in BASIC and Fortran on Data General mini-computers for the Mine Planning, Oil and Gas Exploration, and Minerals Exploration systems.

Later, systems support for Data General minis became my full-time role for some three years. The highlights of this period were the introduction of an X.25-based computer network, the move to the ADS/VS 32-bit virtual operating system, an office automation pilot, and a term as president of the Data General Users Group.

During the fourth quarter of 1982 I purchased my own IBM-PC, with the intention of implementing some software packages I'd designed. Instead, I ended up consulting for small businesses and writing articles for *Your Computer*. This was, and still is, done as Lloyd Borrett, private citizen. It has no connection with BHP. In March '83 I was appointed Personal Computer Co-ordinator for BHP Melbourne.

Late in '83 I stopped taking on consulting work to concentrate on two other projects. The first was starting the Melbourne PC User Group (MELB-PC). That group is now going strong. I currently serve as president and assist in the production of the group newsletter. Although MELB-PC is trying, and I believe succeeding, to carry out its activities in a professional and business-like manner, it's a non-profit user group like most others.

My second project was to start a mail order business, supplying hardware and software for IBM and compatible personal computers at discounted prices. That company, PC Connection Australia, is now becoming widely known but it remains only a part-time interest for me. The company's goal is to introduce some sanity to the pricing of PC products in Australia, and to provide a high level of technical support for a selected range of the excellent products available.

Some people have thought MELB-PC is a group for BHP employees, others have thought PC Connection Australia is a business arm of MELB-PC. I hope the above revelations will serve to clear up

such misconceptions. Now you also have facts to decide if I have a vested interest in any issue.

### How Compatible Is Compatible?

The reports made by microcomputer industry observers on the COMDEX exhibition held late in 1983 all came to the same major conclusion: the IBM Personal Computer has become the de facto standard of the industry. When IBM introduced the PC in 1981, many companies began providing products for the new machine. Now there is a huge array of hardware and software for the PC. This has boosted sales of the PC, and as a result more companies have been induced to design and introduce more products.

At the same time, some firms have created a new market in PC compatibles. IBM's inability to manufacture enough product, and the newcomers being able to offer lower prices and portability, have been key factors in the success of the PC clones. Essentially, these sell because they are compatible with the IBM-PC and can use products designed for the IBM-PC. But how compatible is compatible?

There are levels of compatibility, and at present it seems a lot of advertising is playing on people's misconceptions, laziness and ignorance of this subject. A truly compatible machine would be illegal. It would be a physical and electronic copy of the IBM-PC. Already IBM has been successful in moving against Corona and others for various infringements.

There must be differences between an IBM-PC and a machine claimed to be compatible. Also, there must be differences between each of the so-called compatible machines. So in order to claim PC compatibility, the manufacturers vary their interpretation of the word compatible. Currently, it seems we have both illegal copies and machines which have nothing more in common with the IBM-PC than an Intel 8088 compatible chip in the enclosure.

### Levels of PC Compatibility

**Level 1: Media compatible.** These are machines which have the ability to read and write disks in the formats used by the IBM-PC. The NEC APC, DEC Rainbow 100, Dot, Hewlett Packard HP-150, and Sirius are examples of machines which are not media compatible.

**Level 2: Processor compatible.** These machines use a microprocessor chip such as the eight-bit bus 8088 and

80188, or the 16-bit bus 8086, 80186, and 80286. If done properly, such substitutions need have little effect on compatibility. The more powerful chips can perform some operations faster, which may cause problems for some timing-sensitive software. The Apple Lisa, Olivetti M20, and DEC Professional 350 are not processor compatible.

**Level 3: Operating system compatible.** These are machines which support MS-DOS or IBM's variant, PC-DOS. Nearly all the software for the IBM-PC uses PC-DOS, with most also being made available under MS-DOS at a later date. Machines that offer only CP/M, CP/M-86, P-System, UNIX and other operating systems are not operating system compatible.

**Level 4: Component compatible.** These machines can use the add-on circuit boards designed for the IBM-PC. The Wang PC, Zenith Z-100, and TI Professional are not component compatible.

**Level 5: Character set and keyboard compatible.** Such machines display all the 256 character codes used by the IBM-PC and have keyboards which include the same keys as the IBM-PC.

**Level 6: Video compatible.** IBM-PC displays are memory-mapped. Video compatible machines must use the same video interface and memory addresses as used in the IBM-PC.

**Level 7: System compatible.** These machines duplicate the entire architecture of the IBM-PC. All I/O, RAM, ROM and other addresses, including the routines in BIOS and BASIC ROM, must reside at the same locations as in the IBM-PC.

Most successful PC clones fit into the third level. They use the same disk format, an 8088 or 8086 chip, and MS-DOS. Some, such as the COMPAQ, Columbia, Corona PC, Hyperion, Eagle PC and Chameleon, achieve higher levels. To meet Level 7 would incur the wrath of IBM.

The manufacturers' reasons for trying to emulate the IBM-PC are obvious. But before you choose a PC compatible you must sort out your own motives. Work out which software you need and what level of compatibility those software products require. Consider your requirement for add-on circuit boards and peripherals.

Simply calling a machine IBM-PC compatible unfortunately doesn't make it so. Be very careful of compatibility claims. □

10% Off This Month Only!



**FORTH**  
by MYTEK  
cassette \$35.00  
ROM \$39.00

If you want to break out of the "BASIC" stranglehold, try FORTH. On cassette or handy ROM chip, this language is extensible. You can actually define your own commands and explore the possibilities of an advanced computer language.

**WORDPROCESSOR** by MYTEK  
cassette \$35.00  
ROM \$39.00

One of the truly useful functions a computer can perform is the manipulation and editing of text. This full featured text editor will make your programming easier and improve your writing. Essays and letters will be enhanced by using this professional piece of software.

**BACKGAMMON** by MYTEK  
cassette \$17.50

This ancient and challenging game will pit your wits against the computer. Combine your strategic skills, reckoning of odds and luck to win. Old hands can sharpen up their game against a competitor that is never going to make a silly mistake.

**CHOPPER** by MYTEK  
cassette \$20.00

One of the most popular computer games, this version for the Microbee will give you an adventure you'll never tire of. Sound and Hi-res graphics are combined in an action paced game of high tension and drama.

**EMU JOUST** by MYTEK  
cassette \$17.50

One of the more unusual arcade games. If you've tired of shooting up aliens, try riding around on an emu as a knight jousting with dragons. A popular game with something different.

**DEFENDER**  
cassette \$22.50

The whole battalion of deadly foes are ready to challenge you in this hot new game. Blast the Landers, destroy the Mutants and obliterate the Baiter. Super action graphics include the high powered radar that gives you a central view of the whole invasion scenario. Five ships are available to defend the threatened planet. All your qualities will be taxed to get the high score in this game.

**GHOST MUNCHER AND KILOPEDE**  
cassette \$20.00

Mytek gives you two programs for the price of one in this exciting software package. Ghost Muncher is well known by many people for its ability to absorb your attention for hours. The object is simple, eat the dots in the maze, the result is riveting tension as you attempt to evade the pursuing ghosts. Kilopede is the arcade game of tactics and high speed machine gun attack. You can shoot the centipede quite easily, but it splits into two to give you twice the trouble. Dodge the spider and other garden nasties.

**DUO 3 - DREAMCARDS**

More two for the price of one programs. Thrill to the mysterious adventure in space of Hyperdrive, play Caverns where you try to find hidden jewels while battling fierce dragons.  
32K Microbee  
Cassette \$19.95

**KILLER BEES - DREAMCARDS**

Save Australia from the dreaded swarm of killer bees. Test your skill at using the secret weapons that will save the country.  
32K Microbee  
cassette \$14.95

**DISASSEMBLER**  
by DREAMCARDS \$15.00

If you've ever wondered what a computer actually gets up to, this program will reveal all. Just "Disassemble" your target program and all the programming tricks and techniques of the pro's will be revealed.

**WILDCARDS - VOLUME ONE \$15**

There are more tips, hints and programs in there than you would think possible for only \$15.00. Topics cover everything from printers, music, utilities and graphics to very useful data sheets and graphics design sheets. Anyone after a handy reference guide or people just wanting to know more about the technical aspects of the Microbee will find this book to be a bargain.



### THE MYTEK RANGE OF COMPUTER SOFTWARE

Mytek have put together a range of software that has become renowned for its reliability and high quality. The Microbee's capabilities are fully utilised in the arcade games to give high resolution, realistic movement and action. Serious users will be interested in the utilities available for expanding the software base of the Microbee and exploiting its technical facilities.

**MACHINE CODE TUTORIAL**

cassette \$25  
The technical details of a computer are highly complex, so let the computer teach you about itself. Once you learn all about the fascinating details of the Microbee, you will be able to write programs like the professionals. Have hours of fun interacting directly with the Z80 CPU, the heart of the Microbee computer. Exploit the capabilities of the 6545 video controller chip, the keyboard scanner and parallel and serial interlaces.

**LOGO-BEE**  
cassette \$22.50

Draw designs and patterns using the Microbee hi-res graphics. LOGO-BEE is a powerful subset of the acclaimed LOGO childrens' learning language.

## MICROBEE

**FROGGER**  
cassette \$22.50

Based on the popular arcade game. Get the frog across the deadly road past trucks and cars. Then negotiate the flooded river by jumping onto anything that is floating past. Strategy and skill are required to master this game.

**METEOR RESCUE**  
cassette \$17.50

Another graphics based arcade game, your mission is to rescue earthlings from the planet surface to the mother ship. Dodge the objects that spin by and destroy the ship.

## dreamcards SOFTWARE



**MERLIN DREAMCARDS**

Well written adventures are always enjoyable to play. You will travel back in time to ancient England where many adventures await you. No trite tricks are used to make playing this game miserable, your success or failure is entirely up to your skill and cunning. A different scenario is generated every time you play this game, giving you long lasting satisfaction. Cassette \$24.95.

**DUO 1 - DREAMCARDS**

Try your coolness in a tough situation with the two popular card games of Poker and Casino. Cassette \$14.95.

**PSYCHOTEC 16**

Experimenters into artificial intelligence and mental health will have hours of fun playing with this implementation of one of the oldest and most popular computer games. Will "Eliza" save your sanity or will you destroy Eliza's? This program is written in basic so it can be extended and improved by you. Try it out on your friends and parents. Cassette \$14.95.

**ASTEROIDS PLUS**  
cassette \$22.50

There is action galore in this Microbee version of asteroids. The computer controls flying asteroids that fly towards your rocket ship, as well as the intelligent objects, sound effects and smart missiles that combine to put you on the edge of your seat with excitement.

**TRSBEE** by MYTEK  
cassette \$30.00

The enormous software base of the old TRS-80's is too large to ignore. Now it can be transferred directly on to the Microbee on cassette using TRSBEE. Basic programs are translated as much as possible into Microworld Basic. Machine language programs are loaded directly into memory for editing.

**BASIC TUTORIAL**  
cassette \$20.00

There's nothing better for teaching about computer languages than a computer. Put your Microbee to work with this Basic Tutorial cassette and be guided through its nine graded lessons on the ins and outs of Basic. Ideal for the computer novice.

**DEBUG**  
cassette \$17.50

If it's time to update an old machine language program or time to get a new one going, a DEBUG program is essential. This program will set breakpoints; that is, at any stage in a machine language program the computer can be made to halt to allow memory and CPU registers to be examined under DEBUG control. If your attempts at machine language programming are not working out too well, this program will allow you to trace them to the source of the problem.

**TOUCH TYPE**  
cassette \$20.00

Since the computer keyboard is the main input device for personal computers, it makes sense to learn how to touch type. Using this graded program will make it quick and easy. In no time at all you'll be rattling off programs at such a rate you'll be glad you don't have to hunt and peck away at the keyboard anymore.

**TAPE DOCTOR**  
cassette \$17.50

Sometimes cassettes aren't too reliable. Even one bad bit in a file will cause the tape to stop loading. Tape Doctor will help to fix up the damaged or imperfect files and set disk header parameters.

**MUSIC B**

Anyone who is trying to learn music will find this useful. Tunes can be composed and edited and played. Transpose music instantly. Save and recall tunes using tape. Design a super metronome or tireless backing musician. Cassette \$20.00 Disk Available.

**COMPOSER BEE II**

This program is an excellent aid for learning music and musical theory. On screen graphical representation of music helps learning of written music. Play on screen music, edit and transpose it. Cassette \$20.00. Disk Available.

**DUO 5 DREAMCARDS**

Two games for the price of one. Millipede is a high-res version of Centipedes, an arcade game combining speed and strategy. Try to escape from the maze in game two. Careful though, the mines will blow you up. Cassette \$14.95.

**PENETRATOR - DREAMCARDS**

Fast moving action to test your skill. Blast your way into the enemy planet to destroy the neutron bomb. A special bonus is the facility to design your own custom landscape. Cassette \$19.95.

**MINE DROP - DREAMCARDS**

Have fun driving the tank through the maze dodging the dreaded BINGLE. Drop a mine strategically and you will survive to build up a super score. Cassette \$14.95.

**WILDCARDS - VOLUME TWO \$16**

More information and programs of all sorts from the Microbee owners who brought you volume one. Music, utilities and interfacing are all covered, including tips on getting machine code running. Anyone interested in the amazing technical details of a computer will enjoy both these books.

Microbee is a registered trademark of Applied Technology

Prices subject to change without notice

IN MY LAST column I promised to discuss two programming problems, but only covered one of them. This month we'll take a look at the second of these, which relates to random access files.

## The Bug that Wasn't

I was told some time ago that random file handling commands did not work properly in double-density DOS. Since I had used random access files in my Manual-On-Diskette utilities for both SD and DD systems without any problems, I was curious to see what this bug was. First, let us review some of the random access commands and their actions.

A random access file is a text file which is treated as a series of records of equal length. Because of the constant length it is possible to know exactly how far into the file the third, the tenth or the hundredth record is to be found. This then allows any record to be selected at random for input (GET #1,n) or for output (PUT #1,n), where n = the desired record number.

If we try to GET a record beyond the end of the file, an error message is given. However, we can PUT any record number (within the limit of the disk space or 32767 - whichever is the smaller) without filling in all the intermediate records. Thus, you can PUT records 1 and 2 and then PUT record number 5.

Having done this you can GET any record up to and including number 5. Records 3 and 4 will contain garbage if the disk space set aside for these records has been used previously. Even if the disk has not been used before, the unused records will contain the characters corresponding to the formatting code used. This is a trap for users of random access files. It is therefore good practice to write blanks (= spaces) to any record which for some reason has to be skipped during the creation process, though it is hard to see why anyone would want to skip records.

## SD and DD DOS

All I have said so far applies to both SD and DD DOS versions. DD DOS differs in that it allows different length records to be specified. The default length is 128 bytes, which is also the length of SD random file records. However, when you OPEN a random file under DD DOS you may specify an optional record length. The format is OPEN "R",#<file number>, <file name>, [<record length>].

For example:

```
OPEN "R", #1, "1:TEST:DAT", 256
```

opens a random access file TEST:DAT on drive one, using 256 byte records.

On the other hand, if you try to specify a record length in SD DOS, the system hangs. You do not even get an error message.

If you want to know how many records have been written to the file during previous sessions, the LOF function provides this information. After OPENING the file as a random access file, simply execute N=LOF(<file number>) to find the highest record number PUT to date. But there is another trap here for DD systems. If the record length is not specified correctly in the OPEN statement, LOF will give the wrong result. The system actually seems to keep track of the number of bytes in the file and LOF returns <file length> or <record length>; that is, the result of an integer division of the record length into the number of bytes in the file. So, if we write four records of 256 bytes each, CLOSE the file and OPEN it with a record length of 128 bytes, we will appear to have eight records. LOF will return a value of eight and we can GET records one to eight without causing an error message. The same holds in reverse: a number of short records can be PUT and a smaller number of larger records can be retrieved using GET.

Both of these situations are likely to produce garbage, depending on the field specifications. The field specification is a necessary part of opening a random access file. It specifies how the total record is divided into portions (fields), which are associated with each variable. Thus, a patient record may be made up

of name, address, age, telephone number and so on.

When the field specification is executed it not only assigns the variable names, but it also associates them with specific bytes in the file buffer selected in the OPEN statement. The variable names chosen can therefore not be used as an ordinary string variable because this would change the pointer associated with that variable. The pointer to the file buffer is then lost until another FIELD statement is executed.

## About the Listing

All this is perhaps best seen by looking at the short program in Listing 1. Line 20 OPENS a random access file and line 30 defines the first ten bytes of the buffer as T\$. A string is entered from the keyboard in line 40 and passed to the T\$ segment of the buffer in line 50, filling T\$ from the left. If A\$ is shorter than ten characters, the remainder of T\$ is filled with blanks. If A\$ is longer than ten characters, only the first ten characters go into T\$ and the remainder are lost. Line 60 stores the record to disk as the first record of the file. Line 70 redefines T\$ as an ordinary string variable and though line 90 reads the record from disk again and places it into the buffer, line 100 shows that T\$ no longer points to it.

This was the problem encountered by my friend. It is not a bug, in that you cannot expect to use T\$ as both an ordinary string variable and as part of the random access file buffer. The correct way of handling this is to change line 70 to A\$="TEST":LSET T\$=A\$. This changes the value of T\$ temporarily, without changing its function as part of the random access buffer. □

### Listing 1.

```
10 REM...Random access file test.
20 OPEN "R",#2,"TEMP"
30 FIELD #2,10 AS T$
40 INPUT "String to save ";A$
50 LSET T$=A$
60 PUT #2,1
70 T$="TEST"
80 PRINT "T$ string is ";T$
90 GET #2,T$
100 PRINT "String read is ";T$
```

# Introducing The Squirrel: a smart, small collector that stores and retrieves information.



Sharp introduces the truly portable personal computer. It weighs around 5kg. Slips into a standard briefcase. And works wherever you do.

It's called The Squirrel. But you may call it a godsend especially if you spend a lot of time away from your office.

Wherever you are, just open the case, flip-up the screen, and you're in business. The rechargeable battery lets you work away continuously for around 8 hours.

The easy-change, bubble memory allows you to store data and swap programs in an instant. The powerful memory remembers over 60 typed pages and storage can be expanded to handle over 500.

And with a word processing package you can silently type a letter or memo. The optional integrated printer produces as many neatly typed copies as you need for mailing or meetings.

If you want to communicate without paper, grab a phone and The Squirrel can talk to other computers and databases.

It all means that travel time is no longer down time.

For more information on The Squirrel and the many software packages available, call the Sharp office nearest you for the location of your Squirrel dealer.



TO: Computer and Systems Division  
Sharp Corporation of Australia  
64-72 Seville Street, FAIRFIELD NSW 2165.  
Please send me more information on The Squirrel.

NAME \_\_\_\_\_

TITLE \_\_\_\_\_

COMPANY \_\_\_\_\_

TELEPHONE \_\_\_\_\_

ADDRESS \_\_\_\_\_

POSTCODE \_\_\_\_\_



THE SQUIRREL PC 5000



# SHARP®

Simply the best in computers

Sydney 728 9111, Melbourne 763 9444, Brisbane 343 9144, Adelaide 294 7166, Perth 277 7477, Canberra 805 288.

AP8108F

IT'S A WHILE since I mentioned much in the way of books specifically on CP/M. Two years ago there was one book on CP/M that wasn't published by Digital Research, now there are dozens!

One of the latest entries in the field is *The Programmer's CP/M Handbook* by Andy Johnson Laird, published by Osborne/McGraw-Hill, 1984 (ISBN 0-88134-103-7). Andy Johnson Laird is certainly well qualified to write on the subject: you will find several commercial CP/M implementations bearing his name in the BIOS. His most recent effort is Concurrent CP/M-86 for the newly released ICL 16-bit PC.

Johnson Laird's book is mostly concerned with using BDOS calls effectively and writing a BIOS for CP/M-80 Version 2.2. The book contains two complete BIOS listings plus many, many code examples. Some complete utilities written in C are also presented. Now I don't quite agree with the way the BIOSs are constructed, or with some of the techniques he presents, but this is still a very good book for anyone aspiring to be an assembler application programmer or a BIOS writer in a CP/M environment. My copy cost me US\$21.95 at Stacey's in San Francisco, but I guess it will cost a lot more here. It is currently available in Australia.

Another new book is *The BYTE Guide to CP/M-86* by Mark Dahmke, published by McGraw-Hill, 1984. (ISBN 0-07-015072-9). This book is hardly a heavyweight in the CP/M arena, but it is the only book around on CP/M-86. Dahmke covers the subject well, and the book includes several useful listings of 8086 source code. This isn't just a warmed-over CP/M-80 text, it's a good basic introduction to CP/M-86 for anyone who needs to understand 8086 assembler and the 8086 system interface. My copy cost \$30.95 at the Technical Bookshop in Sydney.

### Misusing Terms

There seems to be a tendency emerging for some people to call all remote access systems 'databases'. While some, such as the mighty DIALOG system in the US, are primarily systems set up for querying specialised databases, many remote access systems have little to do with databases at all.

Similarly the term 'network' is being used to describe systems which have no interconnections at all. There is no network of RCPM systems Australia, and the Australian Beginning is not a network. AUSTPAC is a network (but when are Telecom going to get around to explaining it properly to small system users?).

### MIDAS

*Your Computer* receives a steady stream of mail asking for information about overseas information systems. While we like to get mail, we also like to see it go to the right place. OTC has a fine packet-switched data communications system called MIDAS, for which it is always trying to get new business. Now, OTC figured out long ago that the best way to get Australians using MIDAS was to make information on the systems that can use MIDAS readily available. So if you want details on information systems in the US or Europe, just call OTC and ask them for details of the MIDAS service.

### AUSTPAC and RCPMs

Telecom's AUSTPAC is developing into a fine domestic packet-switched data network. Full commercial rates are now being charged and the maintenance windows have been cut down - so I guess they think it is really ready now.

An often asked question on the

RCPM systems is "When are you going on AUSTPAC?". AUSTPAC is a great boon for casual users who can come in through a dial-up interface, and a great boon for commercial users who can easily justify the cost of a node. Unfortunately, the cost of a node is prohibitively expensive for a 'community' service like an RCPM system. I estimate it would cost a minimum of \$3000 for the additional communications hardware needed to set up an existing async RCPM system as an X.25 node on AUSTPAC. In addition, it would cost a minimum of \$2,500 a year in charges to keep the node on the network.

That's too much money for a single SYSOP to even contemplate for mounting a 'free' service, so it's unlikely that you'll see RCPM-type systems on AUSTPAC unless some philanthropic organisations are prepared to provide substantial financial support (in which case the Software Tools RCPM could go on AUSTPAC in matter of weeks).

### Console I/O under CP/M

The following brief tutorial on CP/M Console I/O is directly applicable to CP/M-80 version 2.2 and CP/M-86 version 1.1. It is also generally applicable in a broader sense to CCP/M and MP/M implementations.

### Fetching Characters from the Console

There are two methods of fetching single characters from the console. The first method uses BDOS function 1 and performs simple direct reading of the characters from the console. Once a call has been placed to this function it will not return until a character is present at the console.

If you need to determine whether a character is available before using BDOS function 1, BDOS function 11 will tell you if a character is waiting at the console.

The second method is to use BDOS function 6 with a passed parameter of FFH. This call will either fetch a character from the console if present, or return a null which indicates there wasn't a character waiting at the console.

Nothing is echoed back to the console to indicate what was entered with either of the above access methods.



# ANNOUNCING

## NEW

# SPELLBINDER 5.30

We are proud to announce this new release of Spellbinder. If you already have a copy of Spellbinder, you may have thought that you had the ultimate. We believe that the best can always be bettered. We've added a dictionary and syntax checker. We've added conditional page-breaks and footnoting. We've re-written the manual completely to give you one of the best reference works on word processing. We've added extra maths functions and extra printers. If you have Spellbinder, call us for an update. We'll better the best. And if you're just looking for a wordprocessor, you can't go past Spellbinder. Our update policy will see to it that you never have second best. Training classes available — call Software Source on 389-6388.



**Software Source Pty Ltd**

(02) 389 6388  
 PHONE FOR THE NAME  
 OF YOUR NEAREST DEALER  
 P.O. BOX 311 BONDI JUNCTION 2022

LNP ARTPRINT

## TANDY ELECTRONICS DEALER

Big Discounts on all Tandy  
Computers and Accessories

Free Delivery Throughout  
Australia

90 Day Warranty

Bankcard and Cheque Orders  
Accepted

**Not Only the Best  
- But the Very Best Service**

Bayne and Trembath  
3 Boneo Rd., Rosebud, Victoria 3940.  
Ph: (059) 86 8288, A/H (059) 85 4947

PRESENTING

# EASY DESK

THE LOW COST MOBILE COMPUTER DESK

*A quality product at a price you can afford.*

- Made in AUSTRALIA
  - Easy assembly
  - For use in the home, office at work or in the class room
  - Packed in cardboard box
  - Laminated in teak
  - Sturdy steel construction
  - Solid castors
  - Courier delivers to your door
  - Dealers' inquiries welcome
  - Cheques, Bankcard
  - Money orders,
- payable to

**IDEAL GIFT!**



ONLY  
**\$99**  
Tax Paid

**HOME COMPUTERS**  
 160 Main Road (Burwood Hwy),  
 Upper Ferntree Gully, Vic. 3156.  
 Telephone (03) 758 2124.

Name .....

Address .....

..... State ..... Postcode .....

Bankcard ..... Signature .....

Cheque enclosed  Bankcard



## Buffered Console Input

BDOS function 10 provides a buffered input from the console, with input editing facilities. This function does echo input back to the console, as it allows limited command line editing.

The user has an opportunity to correct any errors before sending the input to the program, and a number of control characters are recognised and processed for system control purposes. A control-C will force a warm boot of the system *only* when it is the first character of the buffered input line.

Other control characters recognised are outlined in the CP/M documentation. Note that a control-P is *not* recognised by the BDOS as a significant control character, as some CP/M documentation suggests (processing of control-P is done by the CCP).

The length of an input line is finite.

## Sending Characters to the Console

There are two methods of sending single characters to the console.

The first method uses BDOS function 2 and performs a simple direct send of a character to the console. Once a call has been placed to this function, it will not return until the character has been successfully 'sent' by the BIOS. If a BIOS can sense when the physical console device is 'not ready', this call will not return until the console device is sensed as 'ready' and the character is output.

The BDOS maintains a cursor counter which tells it where the cursor is on an output line (in a simplistic sort of way), and the BDOS will expand TAB characters (09H) to eight-column tab stops. This can sometimes produce interesting results if you have sent out random cursor positioning commands to your terminal via the BDOS.

If a control-S has been presented to the console input and read, output will be 'frozen' until another character is entered. Newer versions (CP/M Plus, MP/M, Concurrent CP/M) require a control-Q to restart (this is true XON/XOFF protocol). A control-C presented to the console input after a control-S will force a warm boot of the system.

The second method uses BDOS function 6 with a value other than FFH as the passed parameter. The passed parameter value is sent to the console

with no TAB expansion and no processing of control-S or control-C characters at the input.

## String Output to Console

BDOS function 9 writes a string of characters delimited by an ASCII '\$' to the console. The console must be sensed as 'ready' by the BIOS, and the entire string sent before this call will return.

A control-S presented to the console input, and read, will suspend console output until another character is entered on the console (control-Q only on later versions). A control-C will *not* force a warm boot while console output is being performed by function 9. Unless you don't want your users to be able to break out of a text display, it is not a good idea to display very, very long strings with BDOS function 9. It is better practice to break a long string into several shorter strings and do a console

### Listing 1.

```

*****
*
*   CORTESI CONSOLE OUTPUT EXAMPLE AS MODIFIED BY BILL BOLTON
*
*   From "Inside CP/M", pages 199/200
*
*   September 2, 1983
*
*****
BDOS    EQU    5                ;BDOS entry address
;
C_GET   EQU    1                ;BDOS console fetch
C_PUT   EQU    2                ;BDOS console send
C_STAT  EQU    11               ;BDOS console status
;
        ORG    100H

TOP:
        MVI    C,C_STAT        ;Check console status
        CALL   BDOS
        ORA    A                ;Character ready?
        JZ     SEND            ;No
        MVI    C,C_GET        ;Yes, fetch it
        CALL   BDOS

SEND:
        MVI    E,'X'          ;Character to send
        MVI    C,C_PUT        ;Send it to console
        CALL   BDOS

SPIN:
        LXI    H,0             ;Initialise loop counter
        DCX   H                ;Waste some time
        MOV   A,L              ;Decrement loop counter
        ORA   A                ;Counted down to ecstasy yet?
        JZ    TOP              ;Yes, next character
        JMP   SPIN            ;No, keep counting down

        END

```

## BYTEWRITER

### DAISY WHEEL PRINTER LETTER QUALITY PRINTER AND TYPEWRITER IN ONE PACKAGE

The BYTEWRITER is a new Olivetti Praxis 35 electronic typewriter with a micro-processor controlled driver added internally.

**\$799**

plus shipping  
\$20  
Dealer  
Inquires  
Invited



#### FEATURES

- Underlining • 10, 12, or 15 characters per inch switch selectable • 2nd keyboard with foreign grammar symbols switch selectable • Changeable type daisy wheel • Centronics-compatible parallel input operates with TRS-80, Apple, Osborne, IBM and others • Cartridge ribbon • Typewriter operation with nothing to disconnect • Service from any Olivetti dealer
- Self test program built in.

## BYTEWRITER

CONTACT: COMPUTER EDGE PTY. LTD.,

Showroom:  
229 Chapel Street, Prahran Vic. 3181  
Phone (03) 529 7622

Thinking  
about  
your  
IBM PC/XT

Want one or have one?  
Need to talk to experienced  
people who understand  
your business?  
Looking for application software?  
Want to NETWORK your systems?  
Need training on LOTUS, dBASE 2, PC DOS?  
You should be talking to us.

**THINK  
COMPUTERS**

602 Maroondah Hwy, Mitcham, 3132  
Phone: (03) 873 1122

PLEASE SEND FURTHER INFORMATION **IBM PC/XT**

NAME

COMPANY NAME

ADDRESS

PHONE

## TRS-80 Model 4 CPM



### CPM OPERATING SYSTEM INCLUDES...

- Disk Interchange Format ability to copy 20 other manufacturers' disk formats
- Memlink uses extra memory as a solid state disk drive
- Emulates ADM3A Terminal
- Full Australian Integrated Accounting Software available separately for \$600
- Supplied with all Digital Research utilities
- Makes the Model 4 able to run all CPM Industry standard software

ONLY

**\$250**

### deForest Computers

26 STATION ST., NUNAWADING, VICTORIA 3131.  
TELEPHONE (03) 877 6946 • TELEX AA 30625

## ELECTRONIC PROJECTS FOR CARS

Another topical book in the ETI collection of 'practical project publications. Containing over 20 projects for the electronic hobbyist interested in adding features and facilities to his vehicle, Electronic Projects for Cars over a whole variety of topics — from test instruments to ignition systems, from monitoring instruments to accessories, plus a whole bunch of ideas for the experimenter. Among the topical projects are: ETI-316 Transistor-Assisted Ignition, ETI-319 Variwiper, ETI-333 Reversing Alarm, ETI-328 LED Oil Temperature Meter, ETI 324 Twin-range LED Tacho, ETI-325 Auto-probe Test Instrument, ETI-575 Portable Fluorescent Light Wand, etc, etc.

**All that, and only \$4.95 — It's a steal!**

If your local newsagent or favourite electronics supplier hasn't got a copy, you can obtain one by mail order direct from ETI Book Sales, Federal Publishing, 140 Joynton Ave, Waterloo, NSW 2017 for \$4.95 plus \$1 postage

status check using BDOS function 11, between calls to BDOS function 9 to see if your user wants to abort from the program.

Strings may be arbitrarily long up to limits imposed by memory segments.

## Dangers of Mixing 'Direct' and BDOS Console I/O

BDOS function 6 is often termed 'direct' console I/O, as it bypasses all the BDOS control character trapping and goes directly to the BIOS console routines.

One common trap is to use BDOS function 11 to sense if a character is waiting and then use BDOS function 6 to fetch the character. The call to function 6 under these circumstances will often return a null (no character found), so what happened?

Console input and a character are presented to the BIOS for console input; the BDOS will read the character from the BIOS immediately. The BDOS wants to know if a control-S has been entered at the console. It takes the character from the BIOS (clearing the USART or whatever) and stores it inside the BDOS. The next BDOS function 1 or 10 call will be given the character stored inside the BDOS, rather than fetching one from the BIOS as expected.

A BDOS function 6 call bypasses this mechanism and goes straight to the BIOS, which may legitimately report no console character waiting as the BDOS has already gobbled it up.

The moral is: don't mix BDOS functions 1 and 10 with function 6 unless you are very sure of what you are doing.

In the generally excellent book *Inside CP/M*, author David Cortesi gives an example of console input processing that appears not to work as expected (on pages 199-200). A little thought on the description of BDOS function 1 given above will show why Cortesi's example behaves as it does. A modified version is shown on p.130. It calls BDOS function 1 and clears the character stored internally in the BDOS by reading it. This enables the BDOS to read the next character presented to the BIOS console input and test it for being a control-S. The modified example functions as expected (see Listing 1).

## Concurrent CP/M for IBM-PCs

I have been using a beta test copy of Concurrent CP/M-86 for the IBM-PC and PC/XT with the PCMODE implemented, and it is very nice. The PCMODE allows most common PCDOS programs to run under CCP/M, including some of the 'hard' PCDOS programs like Lotus 1-2-3. PCMODE is due for release at the end of June or early July.

Obviously the PCMODE will only let PCDOS software execute on hardware that is truly IBM-PC compatible. If you have a machine which only runs MSDOS you will only be able to run MSDOS programs in PCMODE under CCP/M-86, for the same reason PCDOS programs fail under MSDOS.

Concurrent CP/M-86 for the IBM isn't supplied with some of the utilities experienced CP/M users may have come to expect. For instance, there is no assembler supplied with the main package. On the other hand, GSX-86 is included. Digital Research has found most CCP/M systems go to end users rather than programmers, and so has left off a few of the programs that would only confuse non-programmers.

However, programmers need not despair. A CCP/M Programmer's Pack is available, which provides the complete 'Programmer's Utilities' package including RASM, LINK, LIB and SID. The Programmer's Pack also includes a programmer's manual for CCP/M-86 (all the BDOS calls detailed); the source to the window manager program as an example of how to use the window functions of CCP/M-86; the SYSTAT utility; and some examples of how to handle communications in a multi-tasking environment.

## PAMS News

Well, the only news is that there isn't much. There are several new systems which are 'on-line' for testing only at this stage. I'd hoped that some of these would have finished their test phases by now, and I could go ahead and publish the numbers ... maybe next month.

Usage of the Software Tools RCPM in Brisbane is now picking up, with about 20 to 30 calls a day. The system had logged well over 11,000 calls by the time it reached its second birthday in mid-May (is it *that* long ago it all started?).

Matt Whelan is passing operational responsibility for the Mi Computer Club

BBS (MiCC-BBS) system over to Evan McHugh, who will be the new SYSOP for that system.

## PAMS Numbers

### Australia

Software Tools RCPM (ST-RCPM): (07) 378 9530 24 hours EST  
 Mi Computer Club BBS (MiCC-BBS): (02) 662 1686 24 hours EST  
 Micro Design Lab RCPM (MDL-RCPM): (02) 663 0151 24 hours EST  
 Sydney Public Access RCPM (SPA-RCPM): (02) 808 3536 24 hours EST  
 Omen RTRS (OM-RTRS): (02) 498 2495 1630-0900 and 24 hours weekends  
 Sydney TRS-80 UG RTRS (STRUG-RTRS): (02) 332 2494 24 hours EST  
 Melbourne CBBS (MICOM-CBBS): (03) 762 5088 24 hours EST  
 Sorcerer CBBS (SCUA CBBS): (03) 836 4616 24 hours EST  
 TARDIS RCPM (TARDIS-RCPM): (03) 67 7760 1800-0800 and 24 hours weekends  
 Gippsland RCPM (GL-RCPM): (051) 34 1563 24 hours EST  
 Adelaide Micro UG BBS (AMUG-BBS): (08) 271 2043 1000-2200 weekends only CST  
 Outback RCPM (OUTB-RCPM): (089) 27 7111 24 hours CST  
 OMEN II RTRS (OM2-RTRS): (089) 27 4454 24 hours CST  
**New Zealand**  
 Attache RBBS (ATT-RBBS): ISD 64 9 76 2039, 24 hours NZT; Domestic (09) 76 2039.



FULLY FLEDGED CP/M HACKERS,  
 & THEIR VERY GOOD FRIENDS,  
 HANGING ONTO THEIR HATS  
 & GOING FOR IT ...

# A word on the care and maintenance of your micro computer...

## Rexel

Computer and Disk Drive Manufacturers recognise the fact that critical components need regular care and maintenance. The Wilson Jones programme, new from Rexel, will halt and disperse the destructive build-up of dust, static and other contaminants that can severely shorten your Micro Computer's life. Regular use of Wilson Jones Computer Care Products can significantly improve performance and eliminate costly down time and data loss caused by neglect.

Without proper care and maintenance your system could be heading for the garbage bin. That's no way to treat your investment, is it?

- **Wilson Jones Head Cleaning Kits** for 5¼" and 8" Disk Drives. Includes 10 pre-saturated disks and reusable jacket.
- **Wilson Jones VDU Cleaning Kit** cleans without abrasion, neutralises static.

Processors and Peripherals. Includes head cleaning disks, VDU cleaner and anti-static spray.

- **Wilson Jones Type Element Cleaning Kit** for printwheel and golf ball Printers. Keeps characters sharp, smudge-free and "letter quality".
- **Wilson Jones Anti-Static Desk Mats** prevent charge sparking through and damaging micro-circuitry in Computers, Electronic Typewriters/Printers, Cash Registers and other Micro Processors.

Wilson Jones, new Computer Care Products from Rexel are available from office and computer supply specialists and wherever quality office products are sold.



Getting the whole world organised.

©C. ITOH  
 ©NATIONAL  
 ©AMUST  
 ©MEDFLY  
 ©DISCOVERY

# COMPAK

Compak Computer Centre

## NOW HEAR THIS!!!

**COMPAK COMPUTER CENTRE SELLS THE AMUST DT80 PRINTER  
 AT THE BEST PRICE ON THE MARKET**

**\$325** INCLUDING TAX

**\$275** EXCLUDING TAX

QUOTE ME AN ADVERT  
 IN THIS MAGAZINE  
 OFFERING THIS PRINTER  
 AT A LOWER PRICE  
 AND I WILL BEAT IT  
 OR MEET IT!

Courier delivery \$8

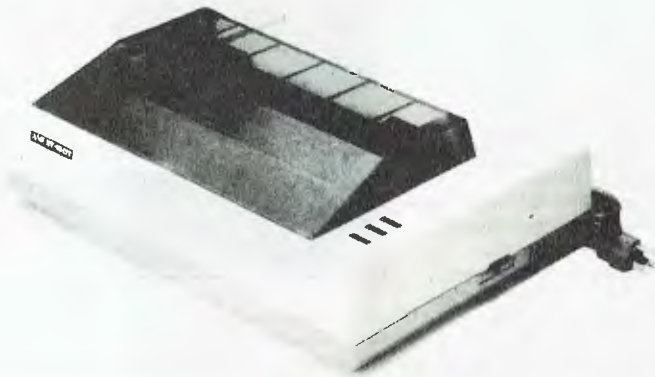

350 South Road, Moorabbin,  
Vic 3189. Tel: (03) 555 9844

# KNOWLEDGEMAN<sup>®</sup>

**A TRUE 16 BIT RELATIONAL DATABASE AND  
 THIRD GENERATION SPREADSHEET FOR**



IBM  
 DEC  
 NEC  
 SIRIUS  
 TEXAS INS  
 OLIVETTI  
 WANG  
 NCR  
 and other assorted 16 bit machines

PC & XT  
 RAINBOW  
 APC

PROFESSIONAL

PC  
 DECISION MATE



- Please send me
- Feature by feature comparison
  - Complete hardware & terminal compatability list
  - Price list
  - Manual\* \$45.00 + postage \$5.00
  - Demo pack\* \$95.00 + postage \$5.00

HARDWARE \_\_\_\_\_ OPERATING SYSTEM \_\_\_\_\_ MINIMUM REC CONFIG 192K RAM, 500Kx2 DISK

\*Purchase price credited on purchase of full system  
 Knowledgeman is trade mark of MDBS Inc.

## MICRO DATA BASE SYSTEMS

P.O. Box 62, Brighton, Victoria 3186.

(03) 529 6372

(03) 523 6311



THERE ARE now two disk controllers to choose from if you want to take advantage of cheaper disk storage. First, there is Dreamcards' \$299 device, which seems to be making its purchasers very happy. Now another contender has arrived in the marketplace: the Buzz Board, a product of the efforts of David Ranger and Greg Tunnock, is a disk controller board which features 64K of dynamic RAM and a real-time clock, and is designed to handle both 13 cm and 20 cm double-sided double-density disk drives, as well as the new 9 cm (3 in) drives. As it stands, Buzz Board will support two drives, but with a small modification this is extended to four.

All of this resides on a double-sided PCB which is the same size as the core-board in the Microbee. This is no coincidence, since the Buzz Board is designed to replace the core-board. That's right - remove the core-board, plug in a Buzz Board, add a drive or two and some software, and there you have it: a 64K disk-based Microbee.

Complete documentation is supplied, along with a DOS and loader in an 8K EPROM. All of the above comes assembled and tested for \$369. If you're interested, you can contact John Vincent at Ed's Electronics, Shop 7, 301 Windsor Street, Richmond 2733; or phone John on (045) 78-4101 during business hours.

### Faster Tape Storage

Disk-based storage is all well and good, provided one has the necessary financial resources. If a disk is still a pipe dream in your computer shack, then perhaps you should look at improving the efficiency of tape storage. The standard Microbee gives us both 300 and 1200 baud. If you push your clock frequency up a little higher, these speeds also increase - nothing phenomenal, though. However, there may be hope. A colleague of mine, one Bruce Neal, has developed tape operating routines which will run on his Exidy Sorcerer (another Z80 in disguise) at speeds between 5000 and 6000 baud. Since these work so well on the Sorcerer, we're going to try them out on the Bee. Providing they work he will probably consider making them available, one way or another.

All this talk about hardware and experimenting to improve the system raises an issue, or at least a couple of points, that intrigue me. We see the release of all these devices, such as disk-controllers, I/O expansion, music and speech interfaces and the recent projects in *Electronics Today*, all of which go to show that the expanded Z80 we know as the Microbee is quite a flexible device.

Most of my time at the keyboard lately has been occupied with real-world interfacing, having just developed an eight-

bit analogue-to-digital interface using one of the National Semiconductor chips. My Bee can actually operate as a slow scan oscilloscope with memory facility. Such things as event monitoring, waveform sampling and dynamic measurement are possible. It's quite fascinating to observe the analogue realm in this fashion.

There's a whole world out there just waiting to be hooked to your computer, and exploring it from the keyboard is a most enlightening activity. Why do I mention this? Well, it's highly unlikely that I'm the only Bee owner experimenting in this fashion, and I wouldn't mind hearing from anyone similarly involved. It may even provide some stimulating ideas for those who are beginning to find that the computer game is a somewhat limited application for their machine.

Who knows, it may be possible to organise some sort of competition - if I can find someone to put up the prize.

### User Groups

Some of the user groups have been sending me copies of their newsletters. Thanks, fellas, they've helped me solve a couple of problems. Why I mention it, though, is that these newsletters contain a great deal of useful information. The standard of the publications is high, and the content indicates there are some quite knowledgeable people out there who are involved with the Microbee. It also shows that many of the user groups are more than just groups of people meeting to play computer games.

Some of the articles in these newsletters are so informative their authors might consider submitting them for publication in *Your Computer*, to allow many more users to benefit from their knowledge and experience.

The December 1983 issue of 'The Sting', published by the Microbee Users' Group of Western Australia, carries a very good plain English approach to programming the PIO in the Bee. Next ▶



## MAX FOR MICROS

Naturally our prices are competitive and our range of computers and peripherals suit both home hobbyists and business persons. BUT our biggest selling feature is STILL the service we give both before and after every sale - TRY US!



(02) 93 1383

AH 908 1718

539 PITWATER RD, BROOKVALE 2100

# PACKED SOLID!

Computers and Computing Volume 4 is packed solid with reviews, projects, programmes and information. It's just about enough to toggle your input port at its maximum baud rate! Available now at your newsagent or through ETI Booksales this book is a must for anyone who is serious about Computers and Computing. Computers and Computing is an ETI Publication. Available from ETI Booksales, 140 Joynton Avenue, Waterloo, 2017. Please add \$1.75 post and packing when ordering.

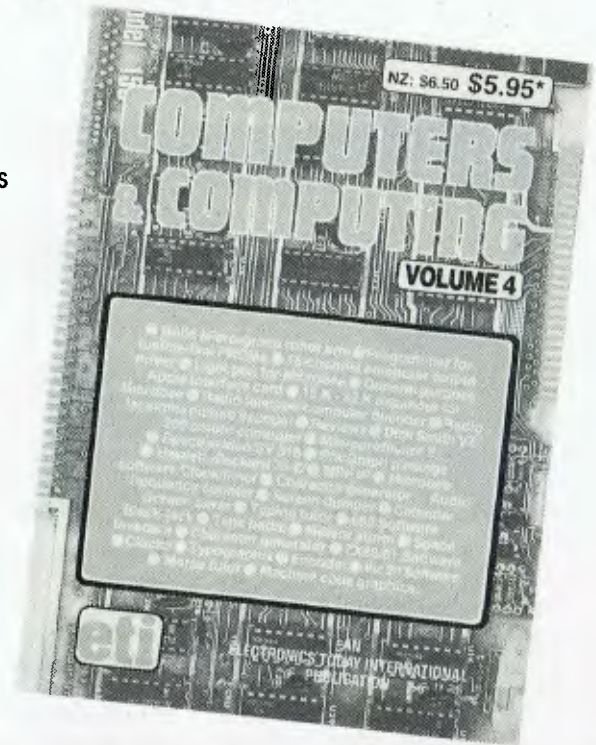

# HI-TECH COMES HOME!

1984 never looked so good! Electronic Lifestyle is the magazine for 1984! It brings you right up to date with what's happening in Video, Hi-Fi, Computers, right down to the terms you'll be using in this electronic lifestyle. Make it your 1984 Yearbook. Available from your newsagent or from ETI Booksales, 140 Joynton Avenue, Waterloo 2017. Please add \$1.75 post and packing when ordering.

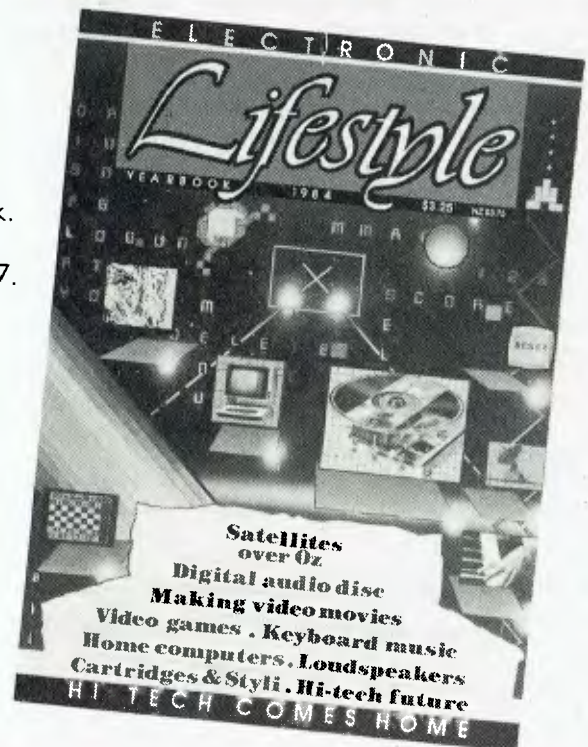

to the 6545 CRTC, the Z80 PIO is perhaps the least understood component in the machine; and there are more than a few users who would like to understand it better.

While I'm on about user groups, here are a couple who would like their existence known. First, the Illawarra Microbee Users' Group now has a phone number on which their organiser, Ronald Read, can be contacted. The number is (042) 71-2384.

Also, the Broken Hill Microbee Users' Group can be contacted through Peter Cotter. Write to Peter at 533 Radium Street, Broken Hill 2880, or phone him after hours on (08) 88-1621.

### Shipwreck Island

From Goodison Software comes an interesting program which at first glance seemed to be an adventure game, but proved to be less a game than a challenge. The documentation supplied with it states its aim is "to provide, by way

of simulation exercise, an awareness of a group's need for co-operation and the sharing of resources, and the benefits of a planned approach to a common problem."

Shipwreck Island sets out to achieve the above claim by marooning the players on a deserted island by way of a shipwreck. Each player has an initial allotment of food, water and some tools. From this point he must act in concert with the others to ensure the group's survival. The game allows activities such as building shelters, food and water gathering and bartering between players. It is necessary that each player pulls his or her weight, otherwise some situations may leave him/her in rather serious trouble or even dead. A reduction in the group's numbers also reduces its chances of survival until the rescue ship arrives.

The program produces a reasonably high-resolution map of the island and, as various areas of the island are

explored, the map is gradually filled in with details, such as forests, lakes and various food sources.

A game for two to five players, Shipwreck Island provides an interesting challenge. You could say it is a practical adventure, both educational and entertaining. My review copy was from Goodison Software, 14 Mollison Street, Broadford 3658. The program is supplied on tape, with documentation, for \$15.

### Shaky BASIC

If you like to add a little realism to those BASIC games, the following contribution from Philip Pulle may be of some interest. It simulates the jarring effect of an earthquake or an explosion. The escape sequences which are used for screen positioning may be treated as string constants and concatenated. When a print statement is executed, with these strings as output, the shaking effect is created. As a demonstration Philip in-

## Sendata 300 Modem Direct Connect

A new direct connect 300 bps modem that is no taller than a 50c piece and fits snugly under the base of a telephone, has been released by Australian communications manufacturer, Electromed. Called the Sendata 300 the modem is simple to operate and does not require operator training. It attaches to the existing telephone wall socket plug and becomes fully operational with the flick of a switch by the operator.

- No installation costs.
- Simple operation.
- Fits under telephone base.
- Attaches to existing telephone plug.

## SENDATA

DEALER AND DEALER ENQUIRIES WELCOME  
ELECTRO-MED  
ELECTRO-MEDICAL ENGINEERING P/L

69 SUTHERLAND ROAD, ARMADALE,  
VICTORIA 3143, AUSTRALIA  
TELEPHONE: (03) 509 5844.  
TELEX: AA34008



## Listing 1

```

100 KWAIT      EQU      8006H
110
120 ASHEX      CALL ASC      ;get first byte
130           LD H,L        ;high byte into H
140 ASC        CALL INKEY    ;get digit
150           RLCA
160           RLCA
170           RLCA
180           RLCA          ;into upper half of A reg
190           LD L,A        ;save it
200           CALL INKEY    ;get next digit
210           OR L          ;create low byte
220           LD L,A        ;into L reg
230           RET          ;with 4 digit hex in HL
240 INKEY      CALL KWAIT    ;wait for keypress
250           SUB 30H       ;to make hex digit
260           JR C,INKEY    ;if less than 0
270           CP 0AH
280           RET C        ;valid 0 to 9 in A reg
290           SUB 7         ;to see if 0A to 0F
300           CP 0AH
310           JR C,INKEY    ;not valid if less than 0A
320           CP 10H
330           JR NC,INKEY   ;not valid if greater than 0FH
340           RET          ;with digit in A reg.
350           END

```

cluded the following program, though I've altered the format slightly.

```

10 CO$ = CHR$(27)
20 U1$ = CO$ + "W":D1 = CO$ + "Z"
30 L1 = CO$ + "A":R1$ = CO$ + "S"
40 E1$ = U1$ + D1$ + L1$ + R1$
50 PRINT E1$;
60 GOTO 50

```

You could, of course, put the PRINT statement at line 50 into a FOR-NEXT

loop to create the effect for a short time each time it was required. Thanks, Philip, you've scored yourself a copy of Wildcards Vol. 1 for that.

Apparently there are no commands to move the cursor around the screen in Microsoft Disk BASIC. Robert Barker from Mont Albert in Victoria submits the following code as a means of overcoming this deficiency:

```

10 DEF FNCUR$(X%,Y%) =
CHR$(27) + "=" + CHR$(31 + Y%)
+ CHR$(31 + X%)

```

```
20 PRINT FNCUR$(2,2);"HELLO"
```

will print HELLO, starting at the second character of the second line of the screen. There goes another copy of Wildcards Vol. 1. Thanks, Robert.

An interesting fact which I've heard a number of people complain about is the higher price of software on disk, compared with that same software on tape. They are not wrong. The trend seems to be that a disk copy of a program costs about \$5 more than its tape counterpart. Now disks don't cost \$5 more than tapes; and since a disk dump of a program can be made at a rate far in excess of a tape dump, it would be interesting to know why there is such a large price difference.

## ASCII To Hexadecimal

There will probably come a time when you write a program that requires keyboard entry of hexadecimal numbers. The routine in Listing 1 does just that. It takes the ASCII entry and converts it into the hex value in the HL reg pair.

ASHEX can be tested by using the following code, which can be entered and assembled with ASHEX.

ORG the lot at 400H and go at 400. The result will be saved in the two hex loca-

## Listing 2

```

60 TSTAS      CALL ASHEX
70           LD (HXSTR),HL
80           RET
90 HXSTR      DW      0

```

tions HXSTR and HXSTR+1. Get the address for HXSTR from the symbol table before you run the program and inspect the result after you have run it. Remember, the 16-bit hex number will be stored in Z80 format; that is, with the low byte in HXSTR and the high byte in HXSTR+1.

Next month I will provide the routine to display the contents of the HL reg pair, in hex, on the screen. You could try and work it out yourself, between now and then.

**68000/6500 PRICES SLASHED**

65C02P-1	6MHz, 64 Pin Dip	A\$28.80
65C02P-1	1MHz, Enhanced instruction set	9.90
65C02P-2	2MHz	10.89
6502A	CPU, 40 Pin, Clock, 64K	6.30
6511AQ	Single Chip Micro, CPU, RAM, 2MHz, RS232, Timer	15.57
6541A	Periph. Controller, RAM, 23 I/O, Host Slave I/F Timer	10.26
6541AQ	2MHz	11.25
6522	VIA 40 Pin, two 8 bit I/O Ports	5.04
6522A	2MHz	5.58
6532A	COMBO 40 Pin, 2MHz	6.95
6545A-1	CRT Controller	10.35
6551	ACIA 28 Pin, SW Prog. Baud Rate	6.03
6551A	2MHz	6.66
6592	Single Chip Printer Controller (for EPSON Series 200 and 500 Printer)	10.35
2716	2K x 8 EPROM 450nSec	4.36
2532	4K x 8 EPROM	6.05
2732	4K x 8 EPROM	6.05
2764	8K x 8 EPROM	12.03
5213	2K x 8, 5V, EPROM	27.00
QUIP 64	Socket for 6511Q and 6541Q	1.85
CRYSTALS	1.8432MHz, 2.00MHz, 32.768KHz, 3.686MHz, 8.00MHz, 4.00MHz, 12.00MHz	2.86
		1.82

Plus Sales Tax, Postage and Pack (where applicable)



P.O. Box 6502, Goodna, QLD. 4300  
BRISBANE — AUSTRALIA  
Phone: 61-7-288 2455/288 2757  
Telex: AA43778 ENECON



**WANTED PROGRAMS REWARD OFFERED**

Become a superstar overnight!

We buy original good quality machine code programs for all popular micros for Australian and International sales.

Games, Educational, Business or whatever.

Turn your hobby into cash.

Contact:  
**Computerplay-Software**  
Your Source of Software  
P.O. Box 69  
Glen Waverley  
3150, Vic.  
Phone: (03) 561 1078

**STOP PRESS**  
JUST ARRIVED  
IN AUSTRALIA



AGC Monitor

- ★ 360° swivel display
- ★ Super high resolution
- ★ Crisp 80 chr. display
- ★ Non-reflective screen
- ★ Resolution: 1000 lines
- ★ 22 M.Hz band width
- ★ F.C.C. Class B. approved
- ★ Attractive styling

**OVERSTOCKED:  
WE MUST CLEAR!!**

Green Screen	\$189 <sup>00</sup>	SAVE \$70.00
Amber Screen	\$199 <sup>00</sup>	SAVE \$80.00

Free delivery to all major centres throughout Australia with orders received this month.

Rush your order to:



Address: 537 Boundary St.  
Spring Hill  
Brisbane. 4000  
Phone: (07) 229 0066

**Australians are dying younger from heart disease.**



National Heart Foundation.

**Loflorien Software**

Cultivating New Concepts  
**COMPUTER SOFTWARE SPECIALISTS**



**EDUCATION**

FRENCH & GERMAN TUTORS,  
SPELLING & SPEED READING,  
AUSTRALIAN GEOGRAPHY,  
THE UNIVERSAL TUTOR  
SCHOOL RECORDS & REPORTS

**ADMIN. & FILING**

ARCHIVE—BIBLIOGRAPHY—  
FILING

THE LIBRARY CATALOGUE.  
THE LIBRARIAN'S ASSISTANT

— LOAN SYSTEM —

**GAMES**

THE CAVERNS OF MORDIA

**G.P.O. BOX 1033,  
SYDNEY 2001  
Phone: (02) 398 4023**

THIS MONTH'S COLUMN includes not one, but two BASIC games: a conversion of Surround, and a BASIC Space Invaders program. The program is not fantastic, but the point of the exercise is that it is not totally impossible to write a reasonable action game in BASIC. So, all you CoCo owners, write some programs and send them in (you can make some money).

**BASIC Space Invaders**

The object of the game ... well, I think I can assume that's common knowledge. If you type Listing 1 into a CoCo with Extended BASIC, you will see a conventional version of the game, minus shields. You use the left and right arrows to control your base, and the space bar to fire. You can hold any of these keys down for continuous movement and firing. This is achieved by PEEKing into the keyboard buffer. To see the effect of the buffer, run the program in Figure 1 (for all CoCos).

Now press some keys - all at once if you like. You will find that each key controls one bit of one memory location. You can AND a memory location with a MASK, to convert the number in the memory location into a form which ignores any other keys which may also be pressed. Table 1 shows all the keys and their appropriate memory locations and masks. For example, if you wanted to see when the ENTER key was depressed, you could type either the listing in Figure 2 or the one in Figure 3.

**Gobbler Review**

Gobbler is a clone of Pac-Man, for the Color Computer. It is produced by Spectral Associates and costs around US\$24. Available on cassette, it comes with a single sheet of instructions including directions on how to transfer the program to disk, which is thoughtful on Spectral's part.

Gobbler is a typical maze/chase game. You start off with five men, and receive an extra man for every 10,000 points accumulated. There are four ghosts which chase you, and four power-pills. After eating a power-pill, the ghosts turn blue. If you eat a blue ghost, the ghost disappears and its eyes return to the central compound as in the real game. After a while, the eyes begin flashing and the ghost becomes nasty

Listing 1. Space Invaders for for CoCos with Extended BASIC.

```

0 A=RND*(TIMER):POKE &HFFD7,0:GOTO16
1 IF PEEK(&H157)=&HFF THENIF PEEK(&H158)=&HFF GOTO4 ELSEG=G+2:ELSEG=G-2
2 IFG<0 THENG=0 ELSEIFG>55 THENG=55
3 PRINT@440+G/2,G$)
4 IF A THENRESET(A,B):B=B+2:IF B>27 THENIF ABS(G+4-A)<3 THENA=0:GOTO11 ELSEA=0:EL
  SESET(A,B,1):ELSEA=INSTR(RND*(LEN(I*(0))),I*(0),W$)+L:IF R<L THENB=INT((Q/32)*2-A
  *2)*0-B*32
5 IF E THENRESET(E,F):F=F+2:IF F<0 THENE=0:RETURN:ELSE:ELSEIF PEEK(&H159)=&HFF TH
  ENRETURN ELSEPLAY"0:RDC":E=G+4:F=26
6 IF E THENIF POINT(E,F)AND&HFE OR POINT(E,F+1)AND&HFE THENQ=INT(F/2)*32+INT(E/2)
  -L+1:Q=INSTR(Q,I*(0),B$):PRINT@L-3,Q$:PLAY"01C00":PRINT@L-3,Q1$:FOR Z=0 T
  O M:MIID$(I*(Z),Z AND1)+Q-3,3)=D$:NEXT:E=0:I=I-1:B=""+SW:PRINT@480,5:IFI=0 THENI
  2
7 IF E THENSET(E,F,4)
8 RETURN
9 IFY<10 THENRETURNELSEIFY=14 GOSUB11:ELSEIF INSTR((14-Y)*32,I*(0),W$) GOTO11 EL
  SEW=LEN(I*(0))-32:FOR Z=0 TO M:I*(Z)=LEFT$(I*(Z),W):NEXT
10 RETURN
11 GN=GN+1:PRINT@L-13,R$:PRINT@L+32,I*(L ANDM):I2Z=127:FOR H=1 TO 25:PRINT@449+
  G/2,CHR$(RND*(Z)+Z):CHR$(RND*(Z)+Z):CHR$(RND*(Z)+Z):PLAY"01C00":NEXT:IF GN T
  HENPRINT@0,"":GOTO20 ELSE30
12 PLAY P$:PRINT@L,I*(L ANDM):W=K+1:GOSUB5:GOSUB1:IF W=14THENY=Y+1:GOSUB9:PRINT
  @L-13,R$:GOTO15
13 L=X+Y*32:GOTO12
14 PLAY P$:PRINT@L,I*(L ANDM):W=K-1:GOSUB5:GOSUB1:IF W=-1 THENX=X-1:Y=Y+1:GOSUB9:
  PRINT@L,R$:GOTO13
15 L=X+Y*32:GOTO14
16 CLEAR1400:CLS:PRINT@261,"YE OLDE SPACE INVADERS":PRINT@360,"BY T.P. CHEN"
17 G$=CHR$(128)+CHR$(211)+CHR$(219)+CHR$(210)+CHR$(128):R$=STRING$(32,128):D$=ST
  RING$(3,128):B$=CHR$(113):O$=STRING$(3,255):Q1$=B$+CHR$(129)+B$:C$=STRING$(46,12
  8)
18 PLAY"L255V31":RESTORE:GN=4:S=0
19 GOSUB21:I=18:W$=MID$(I*(0),2,1):PRINT@0,""
20 FOR ZZ=0 TO 14:PRINTSTRING$(32,128):NEXT:PRINT@490,GN:(X=0:Y=0:L=0:Q=30:A=0
  E=0:PRINT@464,G$):FOR Z=0 TO M:I*(Z)=I*(Z)+STRING$(148-LEN(I*(Z)),120):NEXT:GOTO
  12
21 READ M:IF M=99 THENRESTORE:GOTO21
22 CLEARW:FOR Z=0 TO M:READ Z1,Z2,Z3:A$=CHR$(Z1)+CHR$(Z2)+CHR$(Z3):I*(Z)=B$:FOR
  Z0=1 TO 3:FOR Z1=1 TO 6:I*(Z)=I*(Z)+A$:NEXT:I*(Z)=I*(Z)+C$:NEXT:I*(Z)=LEFT$(I*(Z)
  ),148):NEXT:READ P$:RETURN
23 DATA 1,151,153,128,145,157,146,0100
24 DATA 2,207,205,128,197,205,202,203,207,128,197,203,202,0200E
25 DATA 1,5,231,235,128,129,239,128,030BB
26 DATA 3,5,163,165,128,161,166,162,166,163,128,164,163,162,020AA
27 DATA 3,10,233,233,128,177,185,184,249,249,128,145,153,152,048F253D
28 DATA 3,20,160,194,128,193,190,200,193,184,128,190,195,178,010G
29 DATA 99
30 PLAY"0114,FL4FL8FL4,FL4G#L8GL4GL8FL4FL8EL4F":IF S>H3 THENH3=S:PRINT@8,"NEW HI
  GHSORE":PRINT@42,".....":PRINT@42,"":LINEINP"HS$
31 CLS:PRINT@226,USING"HS$SCORE- ##### % %":HS:H3$:PRINT@253,USING"
  SCORE- ##### %":PRINT@430,"NEW GAME? (Y/N) "
32 EXEC@H199:N$=INKEY$:IF N$="" THEN32 ELSEIF N$="Y" GOTO18 ELSEIF N$<>"N" THEN
  32
  
```

Figure 1. To see the effect of the keyboard buffer.

```

5 CLS
10 FOR X=0 TO 7: PRINT@X*32, PEEK(338+X): NEXT: GOTO10
  
```

Figures 2 and 3. To see when the ENTER key is depressed.

```

10 IF PEEK(338) AND 64 THENPRINT@0, "NOT DEPRESSED"
  ELSEPRINT@0, "DEPRESSED"
20 GOTO10
10 IF NOT PEEK(338) AND 64 THENPRINT@0, "DEPRESSED"
  ELSEPRINT@0, "NOT DEPRESSED"
20 GOTO10
  
```

again. In later stages of the game, the ghosts seem reluctant to acknowledge that you have eaten a power-pill.

There are many bonus fruits, including cherries, strawberries, plums, and even mushrooms! At the end of the game, you can record your name and score, if you were one of the top ten scorers.

I could find no fault with Gobbler, except that your man is a little hard to control with Tandy's joystick (or any joystick which uses potentiometers). People who have a switch-type joystick - in other words an Atari-type joystick - would be at an advantage. At a cost of \$20, Gobbler is a must for any CoCo/Pac-man freak.

If you think Gobbler is too easy, press RESET, type POKE65495,0 to double the CoCo's clock speed, then EXEC8738 to execute Gobbler.

If you think Gobbler is too hard, press RESET, then type POKE9071,n+1, where n is the number of lives you want at the start. Type EXEC8738 to begin.

### Help

Thank you for all your letters. One letter asked for help with converting programs from other computers, especially Surround which appeared in the November '83 issue of *Your Computer*. Listing 2 is a direct conversion for the Color Computer. It will run on all CoCos, and if you change one line (see Listing 3) it will even run on an MC-10. Anyway, if you have any questions about the Color Computer or the MC-10, send them to me:

Tzu-Pei Chen  
6 Kooringa Crescent,  
Mulgrave 3170.

When you ask a question, it would help me greatly if you included what type of CoCo you have (32K? Extended? and so on). Also, please include a stamped, self-addressed envelope.

### Listing 3. 'Surround' converted for the MC-10.

Change: 122 IFT=1THEN124  
Add: 123 GOTO200

Table 1. Keys and their appropriate memory locations and masks.

addr.	MASK						
	64	32	16	08	04	02	01
338	ENTER	8	0	X	P	H	@
339	CLEAR	9	1	Y	Q	I	A
340	BREAK	:	2	Z	R	J	B
341		;	3	↑	S	K	C
342		,	4	↓	T	L	D
343		-	5	←	U	M	E
344		.	6	→	V	N	F
345		/	7	SPACE	W	O	G

Listing 2. 'Surround' for the Color Computer.

```
0  ****SURROUND by KIM HENKEL '83 CoCo VERSION ****
10 CLS:GOSUB750
20 N=5
80 CLS:(S=RND(4))
85 IFS=1THENL$="A" R$="J" GOTO110
90 IFS=2THENL$="D" R$="L" GOTO110
95 IFS=3THENL$="E" R$="I" GOTO110
100 L$="C" R$="N"
110 XL=12:YL=16:XR=51:YR=16
115 FOR X=0 TO 63:SET(X,0,1):SET(X,31,1):NEXT
120 FOR Y=0 TO 31:SET(0,Y,1):SET(1,Y,1):SET(62,Y,1):SET(63,Y,1):NEXT
122 IFT=1THEN124ELSE200
124 I$=INKEY$:IFI$=""THENI$=R$
125 IF ASC(I$)<70THEN200
126 R$=I$
130 IFI$="J"THENXR=XR-1:GOTO140
132 IFI$="L"THENXR=XR+1:GOTO140
134 IFI$="I"THENYR=YR-1:GOTO140
136 IFI$="N"THENYR=YR+1
140 IFPOINT(XR,YR)<>0THEN300
145 SET(XR,YR,3):T=2:GOTO122
200 I$=INKEY$:IFI$=""THENI$=L$
205 IFASC(I$)>70THEN130
210 L$=I$
215 IFI$="A"THENXL=XL-1:GOTO225
217 IFI$="D"THENXL=XL+1:GOTO225
219 IFI$="E"THENYL=YL-1:GOTO225
221 IFI$="C"THENYL=YL+1
225 IFPOINT(XL,YL)<>0THEN400
230 SET(XL,YL,2):T=1:GOTO122
300 FORF=1TO70:SET(XR,YR,RND(8)):SOUND(RND(100),1):RESET(XR,YR):NEXT
305 L=L+1:CLS:PRINT:PRINTTAB(10)LP$:PRINT"WON THAT POINT!":GOTO300
400 FORF=1TO70:SET(XL,YL,RND(8)):SOUND(RND(100),1):RESET(XL,YL):NEXT
405 R=R+1:CLS:PRINT:PRINTTAB(10)RP$:PRINT"WON THAT POINT"
500 PRINT:PRINTTAB(11);"T O T A L"
505 PRINT:PRINTLP$;" HAS WON "L:PRINT:PRINTRP$;" HAS WON "R
510 NG=NG+1:IFNG=N THEN550
520 FORF=1TO1000:NEXT Z=100:GOTO300
580 FORF=1TO4:PRINT:FORFF=1TO100:NEXT:NEXT
600 PRINTTAB(11);"G A M E O V E R"
605 FORF=20TO70:STEP10:SOUND(F,2):NEXT:END
750 INPUT"LEFT PLAYER'S NAME":LP$
753 SOUND240,1
755 INPUT"RIGHT PLAYER'S NAME":RP$
760 PRINTLP$,RP$
765 PRINT" C" ," J"
770 PRINT"R * D" ,"J * L"
775 PRINT" C" ," N"
776 PRINT:PRINT"PRESS ANY KEY TO PLAY"
777 IF INKEY$="" THEN777
780 SOUND250,1:RETURN
```

# CLASSIFIED ADVERTISEMENTS

FREE CLASSIFIEDS are for readers only, not commercial organisations. Classifieds of 20 words or less are accepted free of charge; for classifieds of more than 20 words the first 20 words are free, and then it's 20c a word.

Black and white prints or line drawings may be included if suitable for publication, and will be charged for at \$10 per photograph.

More than one ad per issue will be treated as a single ad and charged accordingly.

COMMERCIAL RATE: Minimum 20 words at 35c a word. Photographs \$20 each.

Print or type your ad clearly and legibly, double-spaced, and include separately your name, address and phone number for our records or checking purposes, even if these details aren't to be included in your ad.

Send it to **YOUR COMPUTER Readers' Classifieds, PO Box 21, Waterloo 2017.**

**Write Of Theft:** Protect your micro, video etc. With the revolutionary marker pen, invisibly mark your telephone number or other identifier. One pen will identify most items in your home/school/company. Only readable with a U.V. light. \$8.50 each. Frazer Electronics, P.O. Box 485 Ringwood, Vic, 3131.

**For Sale:** ZX80/81 16K with full keyboard, 1A power supply, and books and software - \$195 ono. Phone (02) 48 5207.

**Osborne 1:** Including Sanyo monitor, praxis 40 printer, Wordpac, Spellguard graphic slide system, graphics pack, Invaders/Mychess, Adventure, disk box, portable companion magazine incl. premier issue and books. Also, Osborne C/PM user guide, *Using the Osborne Computer* and many more. Twenty disks, user written programs, all cables and modems. Urgent sale - \$4100 ono. Ring Tony on (02) 269 6146, or (02) 797 0769 after hours.

**Apple IIe:** With two drives, green screen, 'heaps' of software (utilities, wp, games) - worth \$8300, sell \$3200 ono. Phone (02) 529 6485.

**Microbee:** Micro-Golf at Beehaven Golf Club. Choose your own clubs, your own length of course and strength of putts. See your score constantly displayed. What happens if you choose the wrong clubs or over-hit the green? Takes 8Kbytes, written in BASIC - \$11.50 mail order to G. Gardoz, 1 Yarana Drive, Mt Helen 3350.

**Microbee:** Match-Play Micro-Golf at Beehaven Golf Club. Play against the computer. Can you win or at least halve the hole? Can you win more holes than the computer? Uses 10K, written in BASIC - \$12.50 mail order to G. Gardoz, 1 Yarana Drive, Mt Helen 3350.

**Microbee:** Limited overs Micro-cricket. A very elaborate version of this popular summer game which you can enjoy any time. If there's no rain, the computer and your team have fifty overs each. The computer bats first. Will suit 32K computer. Mail order (\$24.95) to Computer Biz, 30 Armstrong Street, North Ballarat 3350.

**Epson-Rx-80F/T:** Dot matrix printer. Letter quality, with 1200 fonts. One month old, more reliable than copies. Has quad high-density graphics - others don't. Extremely clear print. Costs \$900 to buy, will sell for \$750 ono. Phone Simon (03) 859 3285 after hours.

**Selling:** Vic-20, datasette, game cartridge, and over thirty other games. All in top condi-

tion - \$150 ono. Phone John on (02) 888 5280.

**VZ200:** Swap programs, inc. Ghost Hunter, Hoppy, Defence Penetrator and more. Write to J Halkiadakis, 101160 Kangaroo Road, Oakleigh 3166.

**To Swap:** Apple software (including CPM) - send list and details of software interest to Wolfgang, PO Box 640, Maryborough 4650.

**Commodore 64:** Educational and games software for Commodore 64. Tape - \$12. Disk - \$16. Includes full instructions. Write to or phone Software 64, 55 Boyana Crescent, Croydon 3136. Phone (03) 725 0176.

**Microbee Software:** Asteroids and machine code tutorial (\$19), Meteor Rescue (\$12), Missile Wars, Space Invaders, Viper, Robot Man, Underworld of Kin, Escape Key, Carace, Lunar Lander (\$10 each). Phone (066) 533 716, (066) 532 273 ah.

**Repairs and maintenance of:** Osborne, Apple, Kaypro, Microbee and so on. Workshop rates are \$28 per hour. Onsite rates are \$38 per hour. Phone Computer Electronics P/L on (02) 429 5893.

**Wanted:** Addresses of suppliers of software/hardware for the System 80. Contact Mr R Schatz, PO Box 17, Koorawatha 2807.

**Vic 20:** Datasette, tapes cartridge, joystick, books, BASIC 1 - all for only \$350. Excellent condition. Phone Joseph Pang on (063) 52 2008.

**VZ200 Software:** As new Poker, Matchbox, Hangman, Golf/Tennis (\$9 each). Learjet (\$18). Write to V Green, 20 Clement Street, Forbes 2871.

**Commodore 64:** Send \$11 and a blank tape for Pac-man, Donkey Kong, Scramble, Secret of Bastow Manor. R Augustynski, 62 Spring Road, Springvale 3172.

**For Sale:** Commodore 64 games. In as new condition - Grave Robbers, Galaxions, 3D Time Trek, Super Dogfight. Each \$15. Tim Dodsworth, Box 917, Ingham 4850.

**System 80:** Business computer. Green screen, books, games, Ectasm, covers - A1 condition. Cost \$1000, sell \$450 ono. Phone (02) 605 5121.

**VZ-200 Software:** VZ-Pacman and VZ-Invaders. Great Action and sound - \$10 each. Doro Nicolosi, 209 Marion Street, Leichhardt 2040.

**For Sale:** Dream 6802, 8K board, power supply, software, sound-generator, joystick, green screen, documentation and teletype

printer (needs repair) \$400. Phone (02) 646 3409.

**Wanted:** Paper tape punch, eight-track - Facit, Teletype or similar. Preferably RS232. Phone (02) 85 3230 after hours.

**Write Off Theft:** Protect your micro, video, etc. With the revolutionary marker pen, invisibly mark your telephone number or other identifier. One pen will identify most items in your home/school/company. Only readable with a U.V. light. \$8.50 each. Frazer Electronics, P.O. Box 485 Ringwood, Vic, 3131.

**Apple II+:** Computer with two disk drives, disk card and Enhancer II board, Kaga green screen monitor - \$1700. Will separate. R Hodgkinson, P.O. Box 578, Albury 2640.

**VZ200:** 24K plus cassette recorder with books and software. Worth \$400, will sell for \$300. Phone (069) 53 4363.

**Tenders:** Coleco-vision game with Zaxxon, Atari Adaptor and Moon Patrol. Worth \$300. Been owned for three months. Contact: Bob, on Yeoval 190.S.

**Microbee:** Wimbledon Tennis for one or two players, has three levels. Tape and listing \$5.00. T. Knowler, 9 Waterman Place, Fraser 2615.

**ETI 660 Computer:** Colour expansion, with 3K RAM - \$141 ONO. TI-59 programmable calculator, manuals, magnetic cards, power supply - \$65. B Begg (08) 31 0310.

**Acoustic Coupler:** Sendata 700, new, one year warranty, power supply, male and female connectors - \$280. Phone (02) 93 3218.

**Wanted:** Logo to run under CP/M 2.2 on NEC 8-bit computer. T Williams, P.O. Box 56, Romsey 3434.

**Peach S/Ware:** Get full map of all your 5" DSD disks including sections not accessible to the DOS, details of masked groups, total number of bytes used and exact location of each file. Output to screen, printer or HIWRITER file - \$30 + \$6 S/T. J Owen, 41 Pacific Highway, Taree Nth 2430.

**Adds Viewpoint 60:** Editing terminal with movable keyboard, programmed function keys 'Regent' 40/60 compatibility - \$1000 ONO. Phone: (02) 98 7229 ah.

**VZ200:** Adventure Program Tape, 'Castle of Elgor'. Requires 24K. Send \$10 only to A Majajas, 99 Wyrallah Road, Lismore 2480.

**BBC Games:** Software needed on DFS disk. Will pay good prices. Reply to J Halkiadakis, 10/160 Kangaroo Road, Oakleigh 3166.

**Microbee 16K IC:** Dick Smith printer, cassette recorder and typing tutor program. Worth \$998, sell \$625. Phone (02) 774-2479.

**Microbee Dual Disk Drives:** These drives plus software such as Wordstar, Multiplan and Microsoft BASIC. Worth \$1600, sell \$1000. Phone (02) 774-2479.

**Apple II Plus:** Green screen, Apple drive 80-col card, 50 educational games, Zardax, Visualc programs - \$1800. Michael (02) 326 2290 (ah).

**Microbee High-Res Graph Paper:** At last! True to scale graph paper, fine enough to allow tracing. Pads of ten - \$1.60; 20 - \$2.95

(add 70c postage). Bee-ware, 4 Garnkirk Road, Greenwood 6024.

**For Sale:** Columbia MPC — fully IBM-PC compatible, with 128K RAM, plus RGB II Monitor, 38 cm star printer, MS-DOS, CP/M 86, Issam database. Retail value is \$7000 plus; selling for \$4750. Ph (ah) (03) 560 7128  
**Vic-20:** Ex-US, b/w since colour system not PAL compatible. Otherwise perfect. Grave Robbers cassette included. \$126 ONO. Phone Tom (047) 31 4492.

**TI-99/4A Computer:** With 16K RAM and a 16-bit processor. Cables, manuals, diagnostic cartridge and books included. Usually \$560, sell \$420. Rodney Gilbert, 25 Holdsworth Road, Bendigo 3550.

**Attention TRS-80 Mod 1/111, System-80**

**Users:** Extended BASIC for '80 Users extends your computer's power from Level II to beyond Disk BASIC. Runs on 16K, 32K, 48K and compiles a customised machine language program of your choice (over 45 routines to choose from), saving it to tape/disk. Minimises RAM usage. Routines include most Disk BASIC commands (except Disk I/O); also the ability to move/copy/re-number program lines, and append/merge/edit programs while retaining variables. Printer functions include in-memory spooler. Keyboard routines include flashing cursor, auto repeat and single key entry. Full support available. Send \$49.95 for program and 60

pages of documentation. Specify tape or disk (specify DOS), or for more details send SSAE to W Sands, 1/19 Gable Street, Mackay 4740. Phone (079) 51 3996.

**Commodore 64 software:** Alpha Attack, a quality presentation of an arcade-type typing tutor. Alien Swarm, an exciting twist on the original 'Space Invaders' theme. Both contain BASIC and Machine Language and are available for \$10 each. For immediate delivery send cheque to Stephen Meagher, 13 Renssion Road, Newhaven 3925.

**SV318/328 Games:** Versions of Pacman, Frogger and Breakout — \$10 each, or all three for \$25. Brian Parker, 19 Barcelona Street, Wishart 4122.

# COMPUTIQUE

## We take the risk and adventure out of buying a computer. Phew!

You've fought through the jungle of computer ads, magazines, books. Maybe even talked to computer suppliers or consultants. It's time you talked to us.

Computique is not only a new name in consumer sales and counselling. We also offer you a new attitude — one that puts you first. We help you through the maze of specifications and claims. Above all, we talk to you in great detail about what to expect from your computer — so we can recommend the one that really meets your needs (along with the software needed to meet your expectations).

The right software usually makes all the difference — and we'll help you make the right choice. We'll continue to help you get full use out of your computer — with newsletters, bulletins, computer training courses — and our "Ask Us" Hotline.

Call us for more information — and a detailed, no-obligation discussion of your computer needs.

**COMPUTIQUE**  
185 Elizabeth Street, Sydney. Telephone  
**(02) 267 8181**

Also at Auburn  
Computique Mail Order Computer Supplies

**STOP PRESS**

### COMPUTER CLEARANCE

**BEST VALUE in Personal Business Computers**

One of the largest selling Computers in the U.S. today



#### EPSON QX10

192K RAM 2 x 230 K Drives  
FX 80 PRINTER Printer Cable  
Wordstar Mailmerge SpellBar  
\$3,862 ex tax

**ALL PRINTERS SLASHED 20%  
FULL BACK-UP SERVICE**

66855

# market directory

DEALERS, distributors, mail-order houses and other commercial organisations or individuals who have a message to spread but don't want to outlay the sums required for full-scale advertising can take advantage of our Market Directory — small ads to help those searching for outlets, services and equipment. For details contact *Your Computer* on (02) 662-8888 or write to PO Box 21, Waterloo 2017.

## B B C micro

**Top Bugbyte Games Software for BBC micro**  
**Twin Kingdom Valley (32K) \$26.95**  
 Adventure. Complex journey 175 colour locations.  
**Oblivion (32K) \$21.95**  
 Arcade. Laser blast the aliens before they zero in.  
**Galaxy Wars (32K) \$21.95**  
 Arcade. The bombers are easy, but watch the H-wings.  
**Robust SureShot Joystick for BBC micro**  
 Single \$34.50 Double \$66.50  
 When other joysticks' unreliability gets at you, it's time for a SureShot. Positive microswitch action.



Australian distributor  
**dolphin computers**

99 Reserve Road, Artarmon 2064. (02)438-4933. Tlx: 20677  
 Mail orders P&P \$5.00 Sydney, \$9.00 Australia.  
 Dealer enquiries welcome.

## "Disk Drive Service And Maintenance"

Mr Floppy Pty Ltd offers full maintenance and "6 Months Service" as recommended on most brands of floppy and hard disk drives. Quick turnaround and very competitive rates.

- ★ Maintenance Contracts available.
- ★ 6 Monthly Service Contracts.
- ★ Used by Govt. departments.

MR FLOPPY PTY LTD  
 9 Ada Avenue  
 Brookvale N.S.W. 2100  
 Tel.: (02) 939-1800. Tlx: AA73775

## CAPTAIN MAIL ORDER COMPUTERS

(a subsidiary of Micro Visions)

**Assorted games on tape.....\$9.99**  
**10 Programs in one of these categories:**  
 TYPE A.... Adventures TYPE B....Arcade  
 TYPE C....Educational

**VHF Modulator for C=64.....\$50**  
**C=64 and Friends.....\$???**  
**Some VIC20 Cartridges @ \$15**  
**ORIC-1 (48K).....\$399 plus FREE game**  
 SPECTRAVIDEO SV.318 plus Datasette plus 4 programs. Expandable to 256K.....\$399

**Send S.A.E. for list & order form to:**  
**PO Box 30, CROYDON, NSW**  
**2132**

## SORCERER OWNERS/USERS

A comprehensive catalogue for SORCERER including GAMES, UTILITIES, EDUCATIONAL, MUSIC CP/M PROGRAMS plus HARDWARE, MEMORY UPGRADES, etc., is now available. REPAIRS "Doctor" service available for ailing Sorcerers.

SSBASIC. This is a direct enhancement of the STANDARD ROM PAC. It comes in four EPROM chips that replace the chips currently in the ROM PAC. SSBASIC supports ALL the original commands PLUS TEN NEW ONES: ie, CALL; CSAVE/CLOAD; CURS; EDIT; EURL (Errortrap); GET; IP (x); O/P(x); PRINT USING and OLD. EPROMS are supplied pin compatible with existing BASIC ROM chips. An incredibly low \$72 is the cost of these EPROMS.

For FREE catalogue of all our programs and services contact:

AURORA DATA SERVICE, P.O. BOX 80, VILLAWOOD 2163



## MF COMPUTERS PTY LTD

9 Ada Avenue, Brookvale,  
 Tel.: (02) 939-1800.

Standard Software COMPLETE SYSTEM FROM \$4800 (Plus tax) Including the table.

- All 8" CP/M 2.2
- Languages: Basic, Cobal, Fortran, CB80, Pascal.
- Communications Software.
- Software available for Business and Home.



MF2000

Approved by the Energy Authority of NSW.

## Laboratory Microsystems Inc.

FORTH for Z80, 8086, 68000, IBM/PC, ICL/PC

FORTH-83 interpreter-compiler with virtual memory management, assembler, customizable full screen editor, line editor, decompiler, demonstration programs and utilities. Extensions to use standard disc files and all operating systems functions. 130+ page manual.

Z80 FORTH for CP/M or MP/M	\$75
8086 FORTH for ICL PC	\$75
8086 FORTH for CP/M 86	\$120
PC/FORTH for IBM Personal Computer	\$120
68,000 FORTH for CP/M 68K	\$300

Nautilus cross-compiler to modify nucleus and/or produce headerless, ROMable code  
 Hosts: Z80, 8080, 8086, IBM/PC, 68000  
 Targets: Z80, 8080, 8086, IBM/PC, LSI-11, 6502, 68000

One host and one target \$350 + FORTH above  
 Other Forth extensions and packages available

## MICROTRIX COMPUTER SYSTEMS

24 Bridge St, Eltham, Vic 3095 Forth (03) 29-2600  
 Other (03) 439-5155

## BIT SWITCH

"BIT SWITCH" designed for versatility of the interconnection of RS232 devices, "one in", "three out", bidirectional change-over switch.



- FEATURES: ★ Low Cost, High Reliability 100% tested.  
 ★ Compact, Fully enclosed, attractive unit.  
 ★ Single P.C.B. with gold DB25 connectors.  
 ★ Low Resistance, GOLD switch contacts.  
 ★ Available with 8 or 24 switched lines.  
 ★ 5 year "local manufacturers" warranty.  
 ★ Simple to use ★ No maintenance ★ No power requirements.

From \$108.00 plus tax if applicable.

MF COMPUTERS PTY LTD  
 9 Ada Avenue, Brookvale 2100  
 Tel.: (02) 939-1800. Tlx: AA73775

## IFR/VFR Flight Simulator \$75

For Apple II+48K DOS 3.3. With omnirange, DME and all other instruments. Real scenery and approaches USA's best

## PRINTER for VIC-20/CMB64 \$225

Use 2 1/4" add machine paper. 30cps 24/32/40 column, dot matrix impact. Gives all commodore graphics, etc. Cable included

## RABBIT for VIC-20/CMB64 \$59

Loads 8Kins 30 seconds. (Your Datasette is a fast as disk). Latest version, will copy protected tapes. C30 tape holds 300K of data

## RAM Cartridge \$105

Either fuel 16K N 8K and 3K. Plugs into rear port

## CHAMBERS COMPUTER

### SUPPLY P/L

Freight FREE on order above \$60, all others are on flat \$5 for p. & p.

48-50 Monkhouse Dr., Endeavour Hills, Vic 3802

## VZ 200 SOFTWARE

An increasing range of quality software. Rapid turnaround of orders and enquiries. Realistic prices and helpful user support.

SUPER INVADERS: 10 levels, fast action and great sound effects.	\$10.00
PAKMAN: 4 different mazes, bonus symbols and great sound effects.	\$10.00
GRAPHICS PACKAGE: Character designer, drawing commands and demonstration.	\$10.00
VZ DEBUG: Disassembler and monitor combined, over 20 commands.	\$20.00
BLANK DATA CASSETTES: Top quality reliable loading everytime.	C12 \$ 1.85 C24 \$ 2.25

HANDLING CHARGES: Per order \$ 1.50

Send S.A.E. for further information or your order to:—  
 R. S. Miller, 8 Mulga St, Altona 3018  
 Phone enquiries: J. Hawley (03) 367 1469

## Z 80 ASSEMBLY LANGUAGE TUITION

PROGRAMMING & APPLICATIONS  
 \$5.00 per hour

PHONE

MIKE NEWNHAM

(047) 21-5417 a.h.  
 (PENRITH AREA)

## ENJOYABLE PROGRAMMING

with  
**HITACHI PEACH MB-6890**

Join our  
 HITACHI PEACH USERS' CIRCLE  
 Australia-wide Postal Group  
 Send 30c stamp for details of membership, and a List of our outstanding software currently available to members.

WHAT-IS WHAT-IF BUSINESS SYSTEMS

34 Lucerne Crescent  
 Frankston 3199

## SOUNDCHASER COMPUTER MUSIC SYSTEMS

### APPLE II REQUIRED

- 16 Channel Performance Software
- Midi Software and Hardware ... (NEW)
- Control up to 16 Synthesisers
- Polywriter Music Transcription ... (NEW)
- Music Tutor Programs Available
- RING Peter Robinson/Les Brazil

## DYNASOUND

Professionals in Music

261 Swanston Street Melbourne 663 2093 663 2064

# sinclair

**ZX-81 Panda 16K Expandable RAM** \$55.00  
Enclosed in case which plugs onto ZX-81. Expands to 32K with expansion module

**ZX-81 16K Expansion Module** \$36.00  
Plugs into socket in ZX Panda 16K. Gives total 32K.

**ZX-81 Professional Keyboard** \$99.50  
Fuller FD. Moving keys, gold plated. Extra keys etc.

### SPECTRUM Enhancements

Large range including printer interfaces, programmable joystick interface, speech synthesizer, beep amplifier, professional keyboard, business & games software. Send S.A.E. for catalogue.



Australian distributor  
**dolphin computers**

99 Reserve Road, Arlarmm 2064. (02)438-4933. Tlx: 20677  
Mail orders P&P \$5.00 Sydney, \$9.00 Australia.  
Dealer enquiries welcome.

## MEDIA COPYING SERVICE

- \* Copying of most formats
  - \* Reasonable rates
  - \* Quick turnaround
- Tel: (03) 772 0781  
(03) 772 9177



## NEW 400/800 + XL UPERMON FOR ATARI

XL owners choose XL or 400/800 oper.sys. at will. 400/800 owners get XL advantages. BOTH have an all based monitor using NO extra memory, giving **FIND, MOVE, CHANGE, ASCII, LIST, STEP, TRACE, VERIFY, HEX/DEC, and DEC/HEX, GOTO, DISK ACCESS and MUCH MORE!**

Orders and Inq. to P.O. Box 507 Beenleigh, 4207, Qld., or phone (07) 209-7891  
400/800 RR — \$89 XL version — \$99

### SINCLAIR ZX SOFTWARE

Gloster Software Announces a new release Multigames pack for the 48K ram ZX Spectrum.

Incredible value—8 full size game programmes, many taking up full 48K ram, computer now, spacetrek, star battle memory, jigsaw puzzle, screen draw and cube.

All programmes fully accessible to user—many games feature our unique sprites graphics with instructions on how to use the routines in your own programmes.

Over \$80 value for only \$29.50 including postage if paid with order. Free ZX81 and ZX Spectrum catalogues available with S.A.E.

Gloster Software  
G.P.O. Box 5460 cc  
Melbourne, 3001.

### RS232 SWITCH PROBLEMS?



Let the RS232 tester help you solve your computer interface problems.

- ★ Simple Connection ★ No Power needed
  - ★ Displays transmit data
- receive data, request to send, clear to send, data set ready, data terminal ready, carrier detect.

\$38.00 post paid Plus tax.  
MF COMPUTERS

9 Ada Ave Brookvale 2100  
Tel.: (02) 939-1800. Tlx: AA73775

### commodore SPECTRAVIDEO Computer Specialist

Scientific & Business applications. Computer courses now running from \$48

NOW AVAILABLE: CBM Business System 8032, 8050, PRINTER plus Stock, Debtors, Creditors, G/Ledger  
Total package.....\$4500

SPECTRAVIDEO SV.318 plus Datasette plus 4 programs expandable to 256K.....\$399

Contact: **MICRO VISIONS**  
472 Anzac Pde., KINGSFORD.  
NSW 2032 Phone: (02) 662-4063

Monitors for any computer or video.  
**AUSTRALIA'S LARGEST  
MAIL ORDER  
SUPPLIER OF MONITORS.**

### HIGH RESOLUTION MONITORS

Green, Amber, RGB, NTSC and Colour Monitors.

Australia's lowest prices starting at \$150 (including 6 months guarantee)

Phone for next day

delivers **VIDEO TECHNOLOGY**  
P.O. Box 181, Petersham, N.S.W. 2049  
Phone: (02) 569-3015

# eti ELECTRONICS TODAY INTERNATIONAL

## AUSTRALIA'S DYNAMIC ELECTRONICS MONTHLY!

Up to date on today's technology.

### June 1984 features:

#### THE INS AND OUTS OF MULTIMETERS

The Multimeter is probably the most important single piece of equipment anyone concerned with electronics will buy. But with the digital revolution in Multimeters, the purchaser is faced with a bewildering variety of fancy shoppes, sizes and range selection schemes. The June issue of ETI looks at the latest in handheld Digital Multimeters, how they work, and the best way to go about choosing one.



#### ELECTRONIC SCALES TO BUILD

For the avid scientific experimenter, general hobbyist, budding chemist, or nouvelle chef, a good set of digital readout scales is like having a third arm — once you've had it a while, you don't know how you ever did without it! This project employs a unique strain gauge bridge technique, printed directly on the pc board. It features four-digit readout and three ranges of 200 gram, 2kg and 5kg. No special mechanical contrivances or impossible-to-get parts used.



#### MAPLE LEAF BRAG

Canada's overseas 'voice', the shortwave broadcaster Radio Canada International, recently upgraded its transmitting facilities and now boasts five 250 kilowatt transmitters. Arthur Cushen tells the story and gives details on their latest schedules for this area.



**\$2.50  
AT YOUR  
NEWSAGENT**

**LETTERS TO THE EDITOR:** We are happy to receive your comments and, if they are of interest to other readers, publish them. Letters will only be considered for publication if they include your name and address, although we can withhold such details from publishing on request. Note that we reserve the right to (and probably will) edit all letters for the sake of brevity, clarity or accuracy.

**Subscriptions:** Standard 12-issue rate within Australia: \$30. Surface rate for New Zealand and Papua New Guinea: \$35.60; airmail rate \$47.60. Save on two years' subscription: Australian rate \$52; surface rate to New Zealand and Papua New Guinea \$63.20; airmail rate \$87.20. Rates for other countries on application. All overseas rates quoted and to be paid in Australian dollars. Twelve months' subscription is available free with membership of the Mi-Computer Club. Allow up to eight weeks for subscription processing.

**BACK COPIES:** and single issues are available from the publisher's office (\$2.50) or by mail (\$3). We will supply photostat copies of articles where a back issue is not available, at the single-magazine price for each feature copied.

**READERS' ENQUIRIES:** We will make every effort to answer readers' written enquiries, if accompanied by a stamped, self-addressed envelope, although staff shortages and deadline pressures may cause delays. **Please include your telephone number(s) with any enquiry.** Phone enquiries not related to subscriptions, readers' advertisements, or other 'service information' cannot be accepted.

**COPYRIGHT:** All material appearing in *Your Computer* magazine is copyright and cannot be reproduced in part or in full, by any means, without the written permission of the Publisher or Managing Editor. Computer clubs and schools can, however, apply for restricted permanent reproduction rights for non-commercial, limited-circulation use (e.g. newsletters and class instruction.) Given that it sometimes takes us a while to answer such requests, you can consider that restricted permanent rights apply in these cases from the day you send in your letter, and will later be confirmed (or withdrawn) by our reply.

**LIABILITY:** Although it is policy to check all material used in *Your Computer* for accuracy, usefulness and suitability, no warranty, either expressed or implied, is offered for any losses due to the use of any material in this magazine.

**EDITORIAL CONTRIBUTIONS:** Contributions to *Your Computer* are welcomed and will be given every consideration\*. Please

read these notes carefully to get an idea of the style and format we prefer.

**All Contributions:** should include your name, address, and home and office phone numbers (in case we need to check details). Each page of your submission, and any material sent with it, should also carry your name.

**Style:** All items should be typed (or printed) and double-spaced on plain white paper. We will only accept original copies - no photostats. Include your name, address, telephone number and the date on the first page of your manuscript (all manuscript pages should have your surname and page number in the top right-hand corner). Be clear and concise, and keep jargon and adjectives to a minimum.

**Contributions By Telephone:** Contributors who have modems and suitable software (in the MODEM7-YAM mould - see our stories on Christensen Protocols in the May and June 1983 issues) can arrange direct transfer to our computers, or obtain special con-

tributor access to the Mi-Computer Club Bulletin Board system, which is on-line 24 hours a day, seven days a week.

**Contributions on disk:** Contributions can be accepted in a wide variety of disk formats, although some we have converted outside our offices, which will add to the (often lengthy) delay between receipt and acknowledgement. The preferred medium is IBM standard format single-sided, single-density 20cm CP/M disks. We can also handle, in-office, Kaypro II and Osborne 13cm disks, MicroBee tapes and 13cm Apple DOS or Apple CP/M disks. If you have one of the formats listed by Archive Computer Services in Brisbane (usually advertised in this magazine), we can accept that too. Please pack them extremely carefully if posting and label all disks with your name, address and phone number.

\*Although the greatest care will be exercised with contributions, no responsibility can be accepted for the safety or return of any letters, manuscripts, photographs or other materials supplied to *Your Computer* magazine. If return is desired, you should include a stamped, self-addressed envelope. If return is critical - say it's something you can't afford to lose - then don't send it; we are careful, but we're not perfect, and Murphy's Law guarantees yours is the one item we'll lose this year.

# Ad. Index

ACT Computers .....	IBC	Imagineering .....	19, 104
AED . 27, 39, YBC15-18, 26 .....		Intelligence Australia .....	54
ANZ Books .....	34	Intelligent Terminals .....	134
AWA Computer Division .....	37	Kenelec .....	YBC27
Adler B:usiness Machines .....	YBC22	Labtam .....	40
Applied Technology .....	16-17	Limco .....	127
Arbiter Computer Systems .....	YBC21	Lothlorien .....	139
Archives Computers .....	OBC	Magmedia .....	53
Arcom Pacific .....	50	Market Directory .....	144-145
Ashton Scholastic .....	YBC31	Maxwell .....	YBC13
Automation Statham .....	48	McLagan Wright .....	YBC2
BGR .....	118-119	MICC .....	136
Bayne & Trembath .....	129	Micro-Educational .....	110-111
Big River Productions .....	122	Micromail .....	30-32
Case Communications .....	42	Microtrix .....	57
City Personal Computers .....	11	Nashua .....	29
Commodore .....	101	Necisa .....	IFC, 3
Compak Computer Centre .....	134	Nissei Sangyo .....	YBC10
CompuSoft .....	139	Olympia International .....	YBC6
Computer Edge .....	131	Osborne Sales Centre .....	YBC24-25
Computer Play .....	139	Ozisoft .....	100
Computer Spot .....	120	PC Connection .....	YBC30
Computermax .....	135	Pacesetter Peripherals .....	58, YBC28
Cubby Hole .....	18	RIFA .....	YBC32
DeForest .....	131	Rexel .....	133
Dick Smith .....	94-95	Rod Irving .....	112, 125
Dolphin Computer .....	13, 144-145	Roland .....	21
Dreamcards .....	12	Sharp .....	127
Electro Med .....	137	Software Corp. of Aust. ....	7
Emona .....	96	Specific Software .....	14
Energy Control .....	139	System Solutions .....	45
Force 4 .....	143	Texas Instruments .....	102-103
Futurtronics .....	99	The Automated Office .....	15
Gambit Games .....	14	Think Computers .....	131
Hi-Tech Software .....	115	Thinking Systems .....	55
Home Computers .....	129	University Co-Op Bookshop .....	8
		Vic Centre .....	123

# ANOTHER HARD ACT TO FOLLOW!

**act**

**FIXED REMOVABLE  
WINCHESTER DISK SYSTEM**

MADE IN AUSTRALIA



## Act's fixed removable disk systems give you MEGABYTES IN THE PALM OF YOUR HAND

### COMPATIBILITY

No matter which micro you have, you can make it ACT. The ACT fixed removable winchester is compatible with most micros —

- APPLE I & IIE • COLUMBIA P.C.
- CORONA/WORDPLEX • DEC RAINBOW 100 • HEATH/ZENITH H89/Z89 • HITACHI PEACH • IBM P.C. • KAYPRO • MICROBEE
- MORROW MICRO-DECISION • NEC APC • NORTHSTAR ADVANTAGE & HORIZON • OSBORNE I & EXECUTIVE
- SANYO MBC-1000 & 555 • SIGMA/OKI MODELS 20 & 30 • SIRIUS • SUPERBRAIN I/II • TANDY II & III • TIME OFFICE
- TOSHIBA T-300 • XEROX 820
- PANASONIC JB-3001 • AND OTHERS.

### A GREAT STORAGE SYSTEM

Combine the best of two storage systems — the speed and capacity of a hard disk and the mobility of a floppy.

You can backup the days data, remove the disk and store it safely or carry it interstate in your briefcase — a great storage system!

### AUSTRALIAN

You don't have to pay more to buy Australian!

ACT is manufactured in Australia and supported by an Australian organisation committed to backup support and service. It's a professional ACT.

A DIVISION OF AUSTRALIAN PROTECTION INDUSTRIES

**act**

Australian Computer and Telecommunications  
75 Willoughby Road, Crows Nest, NSW 2065.  
Telephone 02 439 6300, Telex AA 24816

### DISTRIBUTORS.

Direct Data, 1065 High Street, Armadale, Victoria 3143. Telephone 03 20 6949.

Computer Mart, 356A King William Street, Adelaide, South Australia 5000. Telephone 08 51 5363.



From \$28.00\* per week its the most affordable word processing solution around!

**Offer includes:** • Dedicated word processing computer • 10 software applications and programs • Industry standard CP/M operating system • High quality, full feature visual display terminal • Letter quality printer • Installation and systems familiarisation • Easy to follow instruction driven user interface

## THE WORD TRAVELS FAST!

Archives have placed hundreds of systems into Government, Commerce and Industry over the past nine months. It must be the best value for money pack on offer today. Its' reliability and ease of use make it a tremendous buy for the most inexperienced computer user. There is no need to learn the technicalities as the system is explained in step by step instructions plus applications have "on screen" help!

**Check this for value:** \* Famous WORDSTAR word processor with a spelling checker corrector \* Easy-to-use Database system for information storage and retrieval

\*Lease price to approved purchasers.

\* Powerful financial modelling package \* A bookkeeping suite with extensive reports (MD3 only) \* A cheque book maintenance application \* 3 programming languages including industry standard MBASIC \* Communication software for talking to other systems \* Letter quality printer with an optional cut sheet feeder \* Terminal keyboard dedicated to word processing \* Installation and familiarisation with the system (Metropolitan and certain country areas only).

Contact your local dealer for the details of this offer or book now for a seminar at Archives offices.

 **archives**  
computers australia pty ltd

- 163 Clarendon St, Sth. Melbourne, Vic. 3205. Tel: (03) 699 8377 Telex: ARCAUS AA39388
- 16th Floor, 55 Lavender Street, Milsons Point, NSW, 2061. Tel: (02) 922 3188.
- 419 Remuera Road, Remuera, Auckland 5, New Zealand. Tel: (9) 50 3548